

YAMAHA

SERVICE MANUAL

JH4 Service

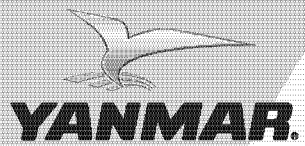

SERVICE
MANUAL

Marine Engines

JH4 Series

3JH4E
4JH4AE
4JH4-TE
4JH4-HTE

YANMAR CO., LTD.

P/N: 0BJH4-G00102

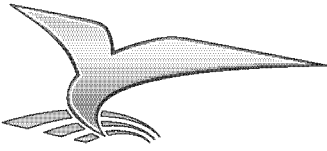

YAMAHA[®]

JH4 **series**

SERVICE MANUAL

3JH4E
4JH4AE
4JH4-TE
4JH4-HTE

P/N: 0BJH4-G00102

MARINE
ENGINES

This *Service Manual* has been developed for the exclusive use of service and repair professionals such as Yanmar authorized Distributors and Yanmar authorized Dealers. It is written with these professionals in mind and may not contain the necessary detail or safety statements that may be required for a non-professional to perform the service or repair properly and / or safely. Please contact an authorized Yanmar repair or service professional before working on your Yanmar product.

Disclaimers:

All information, illustrations and specifications in this manual are based on the latest information available at the time of publishing. The illustrations used in this manual are intended as representative reference views only. Moreover, because of our continuous product improvement policy, we may modify information, illustrations, and / or specifications to explain and / or exemplify a product, service, or maintenance improvement. We reserve the right to make any change at any time.

Yanmar and **YANMAR** are registered trademarks of Yanmar Co., Ltd. in Japan, the United States and / or other countries.

All Rights Reserved:

No part of this publication may be reproduced or used in any form by any means - graphic, electronic, or mechanical, including photocopying, recording, taping, or information storage and retrieval systems - without the written permission of Yanmar Marine International.

© 2007 Yanmar Marine International

0707

**California
Proposition 65 Warning**

Diesel engine exhaust and some of its constituents are known to the state of California to cause cancer, birth defects, and other reproductive harm.

**California
Proposition 65 Warning**

Battery posts, terminals, and related accessories contain lead and lead compounds, chemicals known to the state of California to cause cancer and reproductive harm.
Wash hands after handling.

TABLE OF CONTENTS

	Page
Introduction	1-1
Safety.....	2-1
General Service Information	3-1
Periodic Maintenance	4-1
Engine	5-1
Fuel System	6-1
Cooling System	7-1
Lubrication.....	8-1
Turbocharger	9-1
Starter Motor.....	10-1
Alternator	11-1
Electrical	12-1
Troubleshooting.....	13-1

TABLE OF CONTENTS

Service Standards	14-1
-------------------------	------

Section 1

INTRODUCTION

This manual gives specific instructions for the proper repair of Yanmar JH4 series marine engines.

Please follow the procedures carefully to ensure quality service.

Yanmar recommends that you read this *Service Manual* completely before starting repairs.

Along with standard tools, Yanmar recommends the use of special tools necessary to perform repairs correctly.

Yanmar products are continuously undergoing improvement. This *Service Manual* has been checked carefully in order to avoid errors. However Yanmar is not liable for any misrepresentations, errors of description or omissions. Contact an authorized Yanmar marine dealer or distributor for any questions you have regarding this *Service Manual*.

REVISION HISTORY

This manual is a living document. Periodic manual revisions are published to document product improvements and changes. This practice ensures the manual has the most current information.

As manual revisions become necessary, individual pages are prepared and sent to those who need the information. If a page, or number of pages should be replaced, the replacement information is sent along with a revised Revision Control Table. Discard the older, obsolete information.

At times, the revision involves inserting additional pages in one or more sections. Replace the Revision Control Table and insert the new pages.

This method of revision control represents the most cost-effective solution to providing current, updated information as needed.

Revision Control Table

Revision Date Revision Number	New Page Numbers Involved	Remarks	Initiating Dept.
Jul 2007 Rev. 2	All	Re-release add 4JH4AE	YMU

Section 2

SAFETY

SAFETY STATEMENTS

Yanmar is concerned for your safety and the condition of your marine engine. Safety statements are one of the primary ways to call your attention to the potential hazards associated with Yanmar Marine engines. Follow the precautions listed throughout the manual before operation, during operation and during periodic maintenance procedures for your safety, the safety of others and to protect the performance of your marine engine. Keep the decals from becoming dirty or torn and replace them if they are lost or damaged. Also, if you need to replace a part that has a decal attached to it, make sure you order the new part and decal at the same time.



This safety alert symbol appears with most safety statements. It means attention, become alert, your safety is involved! Please read and abide by the message that follows the safety alert symbol.

DANGER

Indicates a hazardous situation which, if not avoided, *will* result in death or serious injury.

WARNING

Indicates a hazardous situation which, if not avoided, *could* result in death or serious injury.

CAUTION

Indicates a hazardous situation which, if not avoided, *could* result in minor or moderate injury.

NOTICE

Indicates a situation which can cause damage to the engine, personal property and / or the environment or cause the equipment to operate improperly.

SAFETY PRECAUTIONS

There is no substitute for common sense and careful practices. Improper practices or carelessness can cause burns, cuts, mutilation, asphyxiation, other bodily injury or death. This information contains general safety precautions and guidelines that must be followed to reduce risk to personal safety. Special safety precautions are listed in specific procedures. Read and understand all of the safety precautions before operation or performing repairs or maintenance.

DANGER

The safety messages that follow have **DANGER** level hazards. These safety messages describe a hazardous situation which, if not avoided, **will** result in death or serious injury.



NEVER permit anyone to install or operate the engine without proper training.

- Read and understand this *Service Manual* before you operate or service the engine to ensure that you follow safe operating practices and maintenance procedures.
- Safety signs and decals are additional reminders for safe operating and maintenance techniques.
- See your authorized Yanmar Marine dealer or distributor for additional training.

Crush Hazard



NEVER stand under a hoisted engine. If the hoist mechanism fails, the engine will fall on you.

ALWAYS secure the engine solidly to prevent the engine from falling during maintenance.

WARNING

The safety messages that follow have **WARNING** level hazards. These safety messages describe a hazardous situation which, if not avoided, **could** result in death or serious injury.

Explosion Hazard



While the engine is running or the battery is charging, hydrogen gas is being produced and can be easily ignited. Keep the area around the battery well-ventilated and keep sparks, open flame and any other form of ignition out of the area.

ALWAYS turn off the battery switch (if equipped) or disconnect the negative (-) battery cable before servicing the equipment.

Fire and Explosion Hazard



Diesel fuel is flammable and explosive under certain conditions.

NEVER use a shop rag to catch the fuel.

Wipe up all spills immediately.

NEVER refuel with the engine running.

Store any containers containing fuel in a well-ventilated area, away from any combustibles or sources of ignition.

WARNING**Fire Hazard**

Have appropriate safety equipment available. Have all fire extinguishers checked periodically for proper operation and / or readiness.

ALWAYS read and follow safety-related precautions found on containers of hazardous substances like parts cleaners, primers, sealants and sealant removers.

Undersized wiring systems can cause an electrical fire.

Entanglement Hazard

NEVER leave the key in the key switch when servicing the engine. Attach a "Do Not Operate" tag near the key switch while performing maintenance on the equipment.

ALWAYS stop the engine before beginning service.

If you must service the engine while it is operating, remove all jewelry, tie back long hair and keep your hands, other body parts and clothing away from moving / rotating parts.

Piercing Hazard

Avoid skin contact with high-pressure diesel fuel spray caused by a fuel system leak such as a broken fuel injection line. High-pressure fuel can penetrate your skin and result in serious injury. If you are exposed to high-pressure fuel spray, obtain prompt medical treatment.

NEVER check for a fuel leak with your hands. ALWAYS use a piece of wood or cardboard. Have your authorized Yanmar Marine dealer or distributor repair the damage.

Flying Object Hazard

ALWAYS wear eye protection when servicing the engine or when using compressed air or high-pressure water. Dust, flying debris, compressed air, pressurized water or steam may injure your eyes.

Coolant Hazard

Wear eye protection and rubber gloves when you handle Long Life engine coolant. If contact with the eyes or skin should occur, flush eyes and wash immediately with clean water.

⚠ WARNING**Sever Hazard**

NEVER wear jewelry, unbuttoned cuffs, ties or loose-fitting clothing and ALWAYS tie long hair back when working near moving / rotating parts such as the flywheel or PTO shaft. Keep hands, feet and tools away from all moving parts.

The propeller may rotate during towing or if the engine is running at idle speed. NEVER service the engine while being towed or when the engine is running.

If the vessel has more than one engine, NEVER service a engine if either of the engines are running. In multi-engine configurations the propeller for an engine that is shut down may rotate if any of the other engines are running.

Electrical Hazard

Make welding repairs safely.

- ALWAYS turn off the battery switch (if equipped) or disconnect the negative (-) battery cable and the leads to the alternator when welding on the equipment.
- Remove the multi-pin connector to the engine control unit. Connect the weld clamp to the component to be welded and as close as possible to the welding point.
- NEVER connect the weld clamp to the engine or in a manner which would allow current to pass through a mounting bracket.
- When welding is completed, reconnect the leads to the alternator and engine control unit prior to reconnecting the batteries.

ALWAYS keep the electrical connectors and terminals clean. Check the electrical harnesses for cracks, abrasions, and damaged or corroded connectors.

NEVER turn off the battery switch (if equipped) or short the battery cables during operation. Damage to the electrical system will result.

Exhaust Hazard

All internal combustion engines create carbon monoxide gas during operation and special precautions are required to avoid carbon monoxide poisoning.

- NEVER block windows, vents, or other means of ventilation if the engine is operating in an enclosed area.
- ALWAYS ensure that all connections are tightened to specifications after repair is made to the exhaust system.

Burn Hazard

Some of the engine surfaces become very hot during operation and shortly after shut-down.

- Keep hands and other body parts away from hot engine surfaces.
- Handle hot components with heat-resistant gloves.

⚠ WARNING

Sudden Movement Hazard

The engine lifting eyes are engineered to lift the weight of the marine engine only. **ALWAYS** use the engine lifting eyes when lifting the engine.

Lifting Hazard

Additional equipment is necessary to lift the marine engine and marine gear together. **ALWAYS** use lifting equipment with sufficient capacity to lift the marine engine.

If you need to transport an engine for repair, have a helper assist you attach it to a hoist and load it on a truck.

Alcohol and Drug Hazard



NEVER operate the engine while you are under the influence of alcohol or drugs or are feeling ill.

Exposure Hazard



ALWAYS wear personal protective equipment including appropriate clothing, gloves, work shoes, eye and hearing protection as required by the task at hand.

Tool Hazard

Always remove any tools or shop rags used during maintenance from the area before operation.

⚠ CAUTION

The safety messages that follow have **CAUTION** level hazards. These safety messages describe a hazardous situation which, if not avoided, **could** result in minor or moderate injury.



ALWAYS wear eye protection when servicing the engine or when using compressed air or high-pressure water. Dust, flying debris, compressed air, pressurized water or steam may injure your eyes.

Poor Lighting Hazard

Ensure that the work area is adequately illuminated. **ALWAYS** install wire cages on portable safety lamps.

Tool Hazard

ALWAYS use tools appropriate for the task at hand and use the correct size tool for loosening or tightening machine parts.

NOTICE**The safety messages that follow have NOTICE level hazards.**

Any part which is found defective as a result of inspection or any part whose measured value does not satisfy the standard or limit must be replaced.

ALWAYS tighten components to the specified torque. Loose parts can cause equipment damage or cause it to operate improperly.

Only use replacement parts specified. Other replacement parts may affect warranty coverage.

NEVER attempt to modify the engine design or safety features such as defeating the engine speed limit control or the diesel fuel injection quantity control.

NEVER attempt to adjust the low or high idle speed limit screw. This may impair the safety and performance of the engine and shorten its life. Modifications of this type may void the warranty. If adjustment is ever required, contact your authorized Yanmar Marine dealer or distributor.

Modifications may impair the engine's safety and performance characteristics and shorten the engine's life. Any alterations to this engine may void its warranty. Be sure to use Yanmar genuine replacement parts.

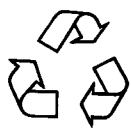

ALWAYS be environmentally responsible.

Follow the guidelines of the EPA or other governmental agencies for the proper disposal of hazardous materials such as engine oil, diesel fuel and engine coolant. Consult the local authorities or reclamation facility.

NEVER dispose of hazardous materials by dumping them into a sewer, on the ground or into ground water or waterways.

If any indicator illuminates during engine operation, stop the engine immediately. Determine the cause and repair the problem before you continue to operate the engine.

Make sure the engine is installed on a level surface. If a Yanmar Marine Engine is installed at an angle that exceeds the specifications stated in the Yanmar Marine Installation manuals, engine oil may enter the combustion chamber causing excessive engine speed, white exhaust smoke and serious engine damage. This applies to engines that run continuously or those that run for short periods of time.

LOCATION OF SAFETY LABELS

To ensure safe work, safety labels are attached. The location of labels is shown below and they should always be visible. Replace if damaged or lost.

3JH4E Engine

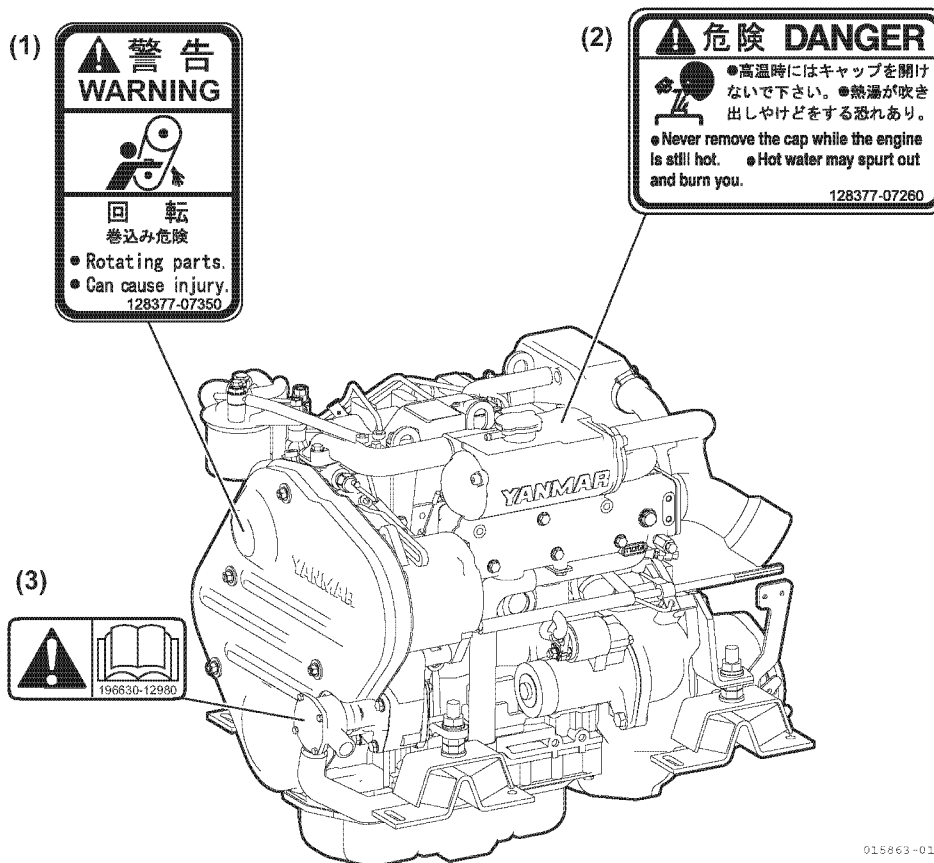

Figure 2-1

- 1 – Part No.: 128377-07350
- 2 – Part No.: 128377-07260
- 3 – Part No.: 196630-12980

4JH4AE Engine

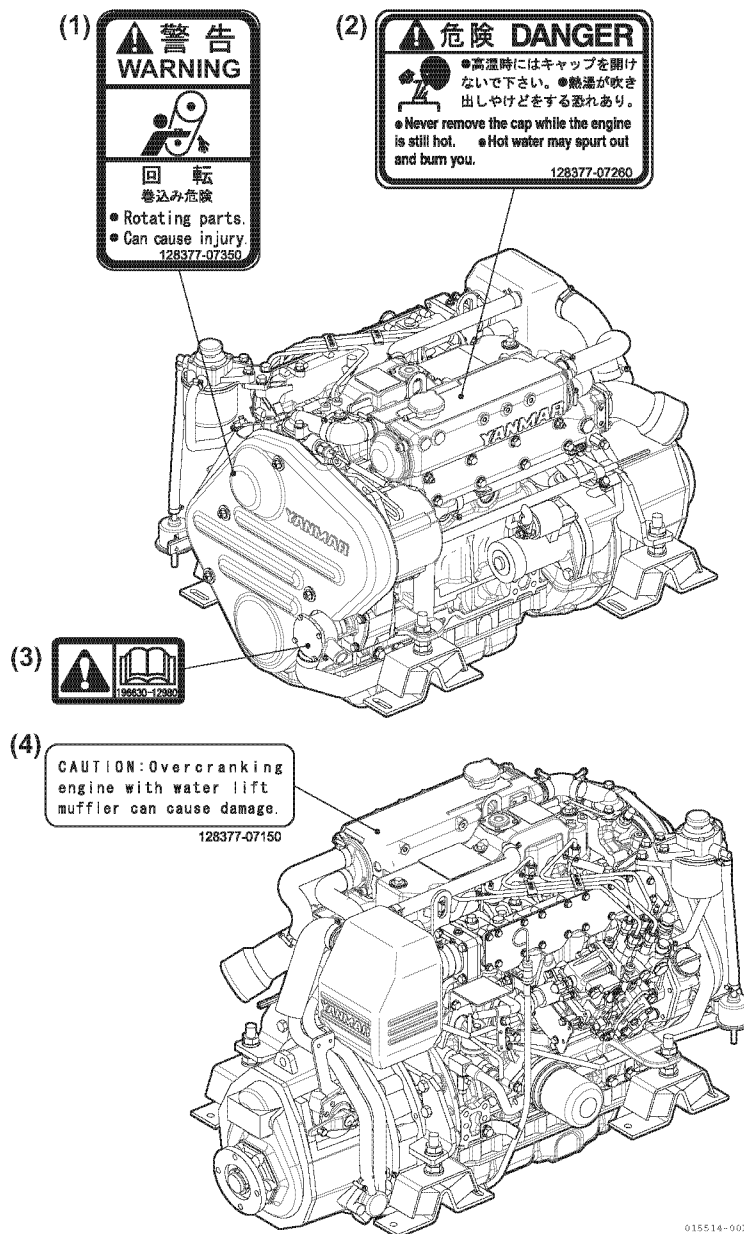

Figure 2-2

1 – Part No.: 128377-07350
 2 – Part No.: 128377-07260

3 – Part No.: 196630-12980
 4 – Part No.: 128377-07150

4JH4-TE Engine

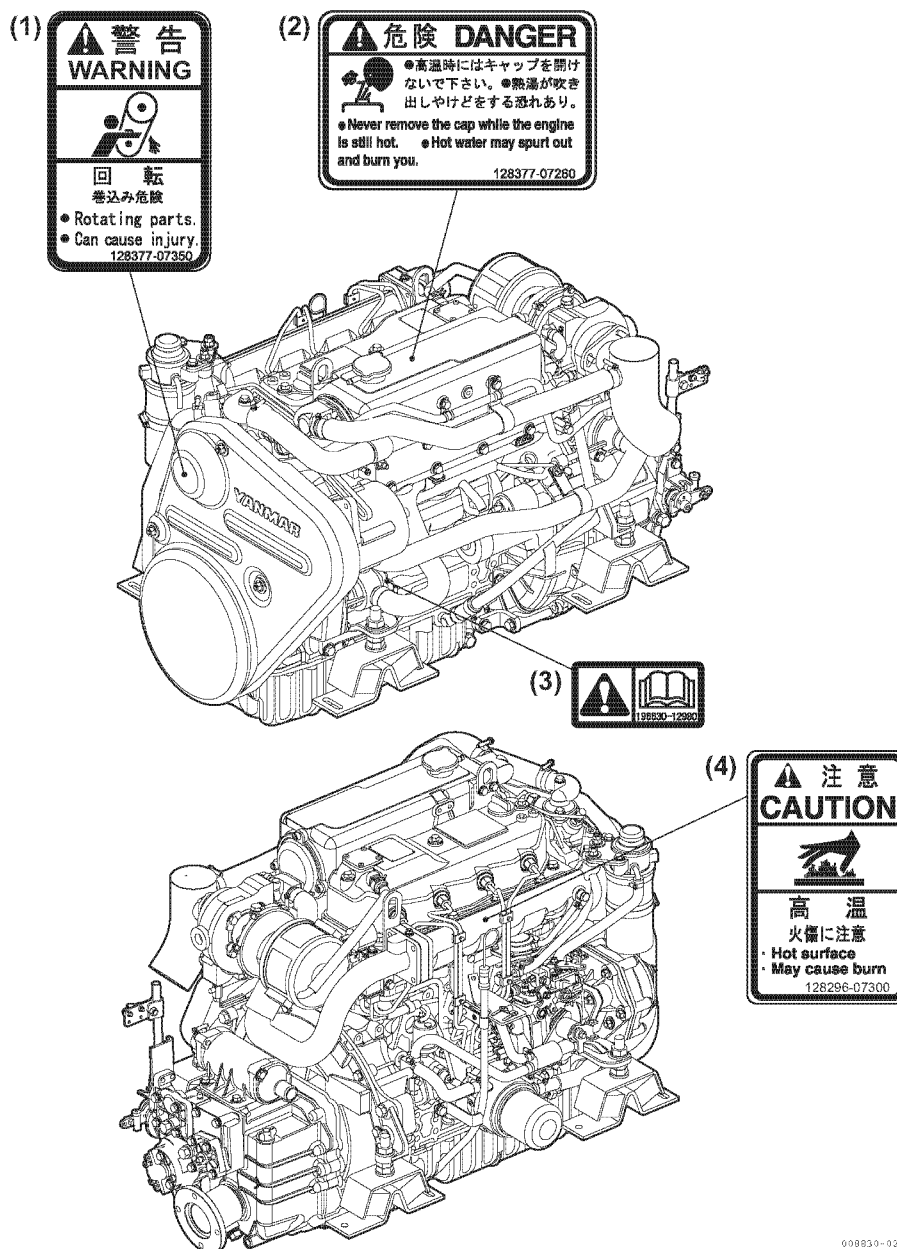

Figure 2-3

- 1 – Part No.: 128377-07350
- 2 – Part No.: 128377-07260

- 3 – Part No.: 196630-12980
- 4 – Part No.: 128296-07300

4JH4-HTE Engine

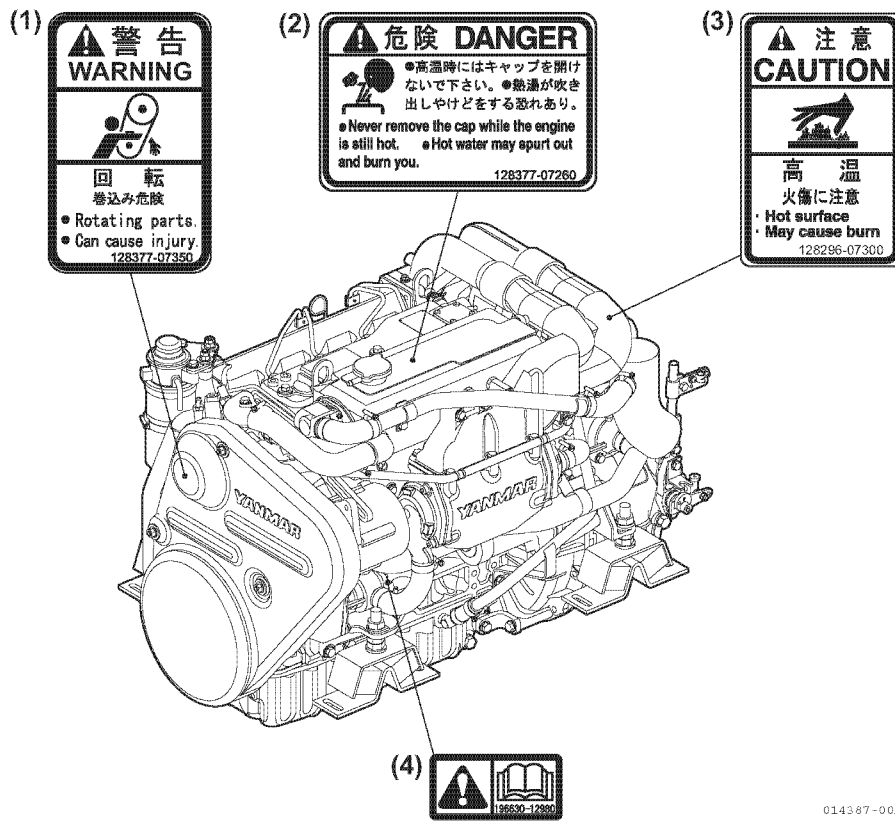

Figure 2-4

1 – Part No.: 128377-07350

2 – Part No.: 128377-07260

3 – Part No.: 128296-07300

4 – Part No.: 196630-12980

Section 3

GENERAL SERVICE INFORMATION

	Page
Safety Precautions	3-3
Engine Outline Drawings.....	3-4
3JH4E Models	3-4
4JH4AE Models.....	3-8
4JH4-TE Models.....	3-14
4JH4-HTE Models	3-20
Engine Piping Diagrams.....	3-25
3JH4E Models	3-25
4JH4AE Models.....	3-27
4JH4-TE Models.....	3-31
4JH4-HTE Models	3-35
Location of Nameplates.....	3-38
Engine Nameplates (Typical)	3-38
Diesel Fuel	3-39
Diesel Fuel Specifications	3-39
Bleeding the Fuel System.....	3-40
Engine Oil.....	3-43
Engine Oil Specifications.....	3-43
Engine Coolant.....	3-44
Engine Coolant Specifications.....	3-44
Principal Engine Specifications	3-45
3JH4E Engine Specifications	3-45
4JH4AE Engine Specifications	3-47
4JH4AE Specifications (Continued)	3-48
4JH4AE Specifications (Continued)	3-49
4JH4-TE Engine Specifications	3-51
4JH4-HTE Engine Specifications	3-53

GENERAL SERVICE INFORMATION

Tightening Torques for Standard Bolts and Nuts	3-55
Hexagon Bolts and Nuts.....	3-55
Hose Clamps.....	3-55
Prepare Engine for Long-Term Storage.....	3-56
Abbreviations And Symbols	3-57
Symbols.....	3-57
Unit Conversions	3-58
Unit Prefixes	3-58
Units of Length	3-58
Units of Volume	3-58
Units of Mass.....	3-58
Units of Force	3-58
Units of Torque.....	3-58
Units of Pressure.....	3-58
Units of Power	3-58
Units of Temperature.....	3-58

SAFETY PRECAUTIONS

Before you service the engine, read the following safety information and review the *Safety Section on page 2-1*.

WARNING

The safety messages that follow have **WARNING** level hazards. These safety messages describe a hazardous situation which, if not avoided, *could* result in death or serious injury.

Fire Hazard



Avoid injury or equipment damage from fire. Undersized wiring systems can cause an electrical fire.

Electrical Hazard



Avoid personal injury or equipment damage. ALWAYS keep the electrical connectors and terminals clean. Check the electrical harnesses for cracks, abrasions, and damaged or corroded connectors.

NEVER turn off the battery switch (if equipped) or short the battery cables during operation. Damage to the electrical system will result.

ENGINE OUTLINE DRAWINGS

Note: All dimensions are metric (mm).

3JH4E Models

3JH4E - Inboard Version (KM35P)

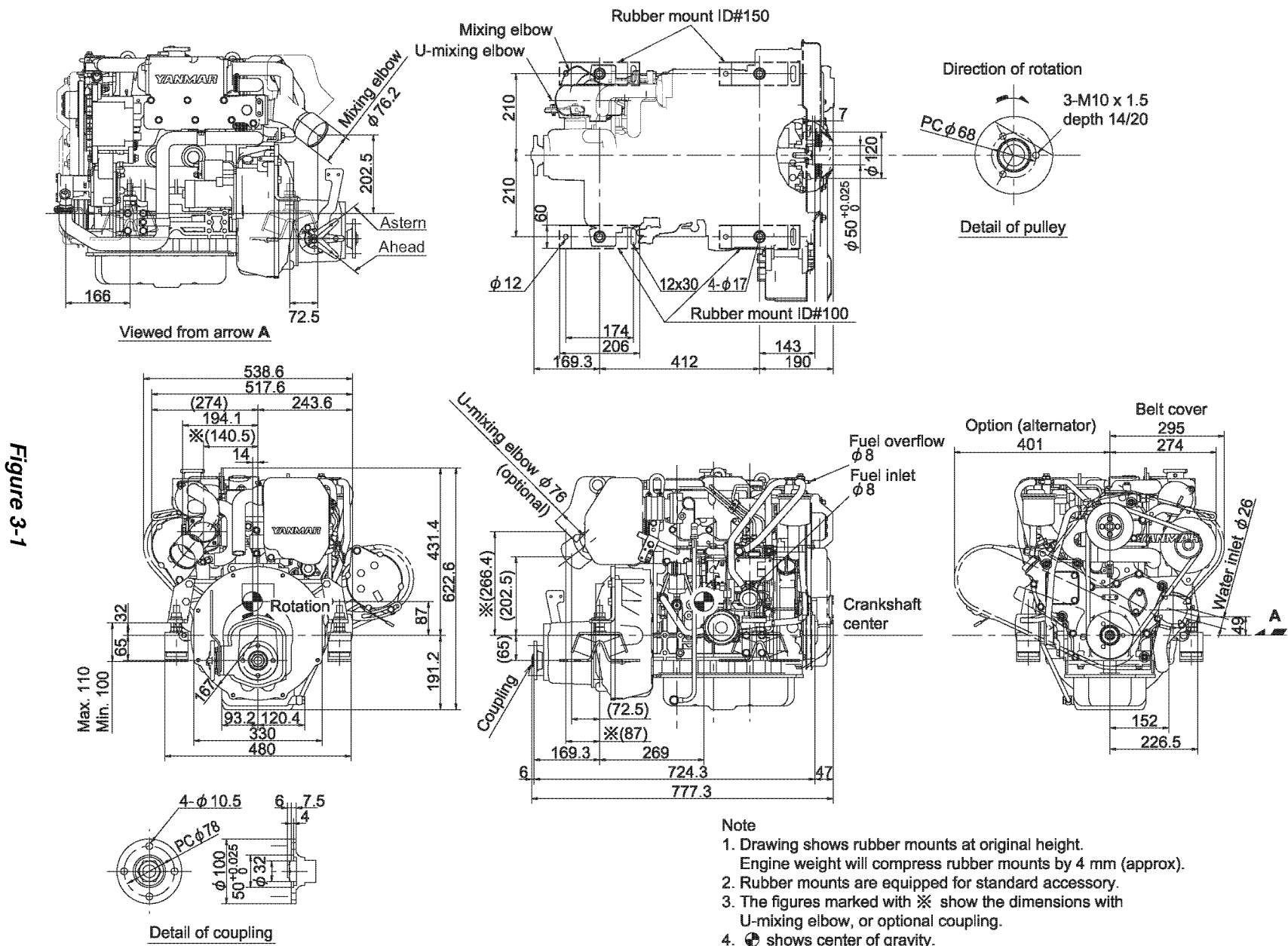

- Note
1. Drawing shows rubber mounts at original height. Engine weight will compress rubber mounts by 4 mm (approx).
 2. Rubber mounts are equipped for standard accessory.
 3. The figures marked with ※ show the dimensions with U-mixing elbow, or optional coupling.
 4. ● shows center of gravity.

Figure 3-1

3JH4E - Inboard Version (KM35A)

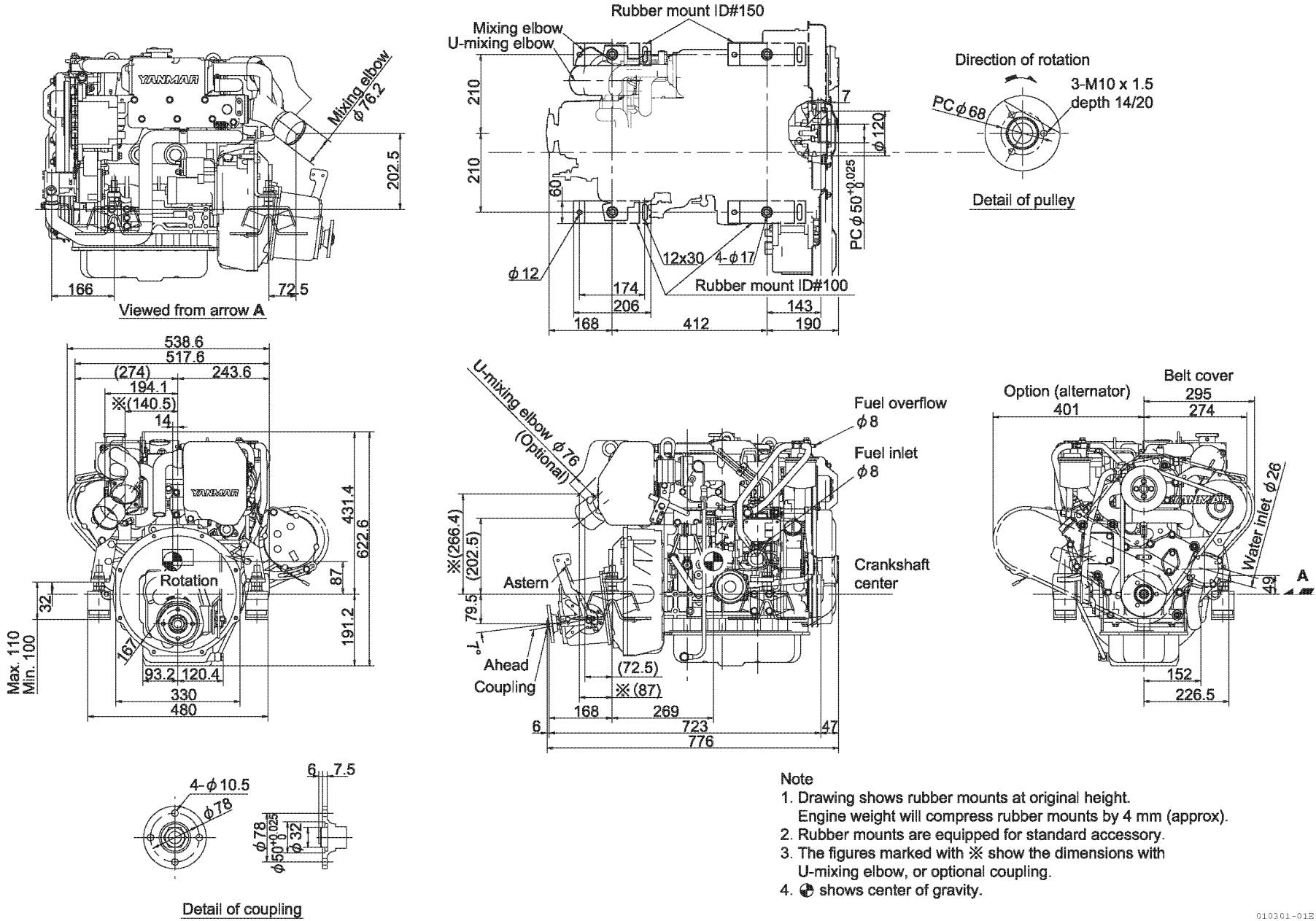
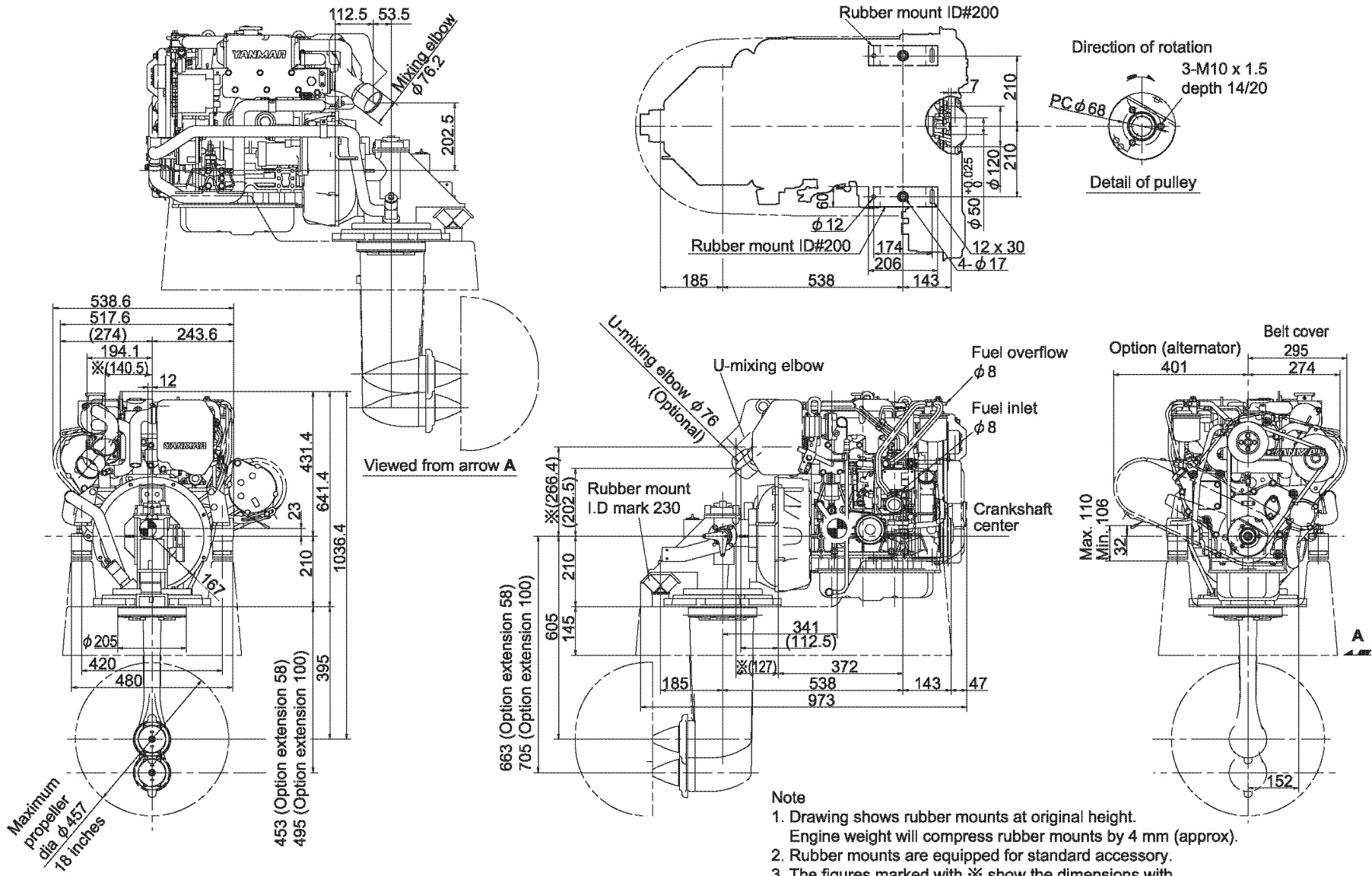

Figure 3-2

010301-01E

3JH4E - Sail Drive Version (SD50/SD40)



011211-01E

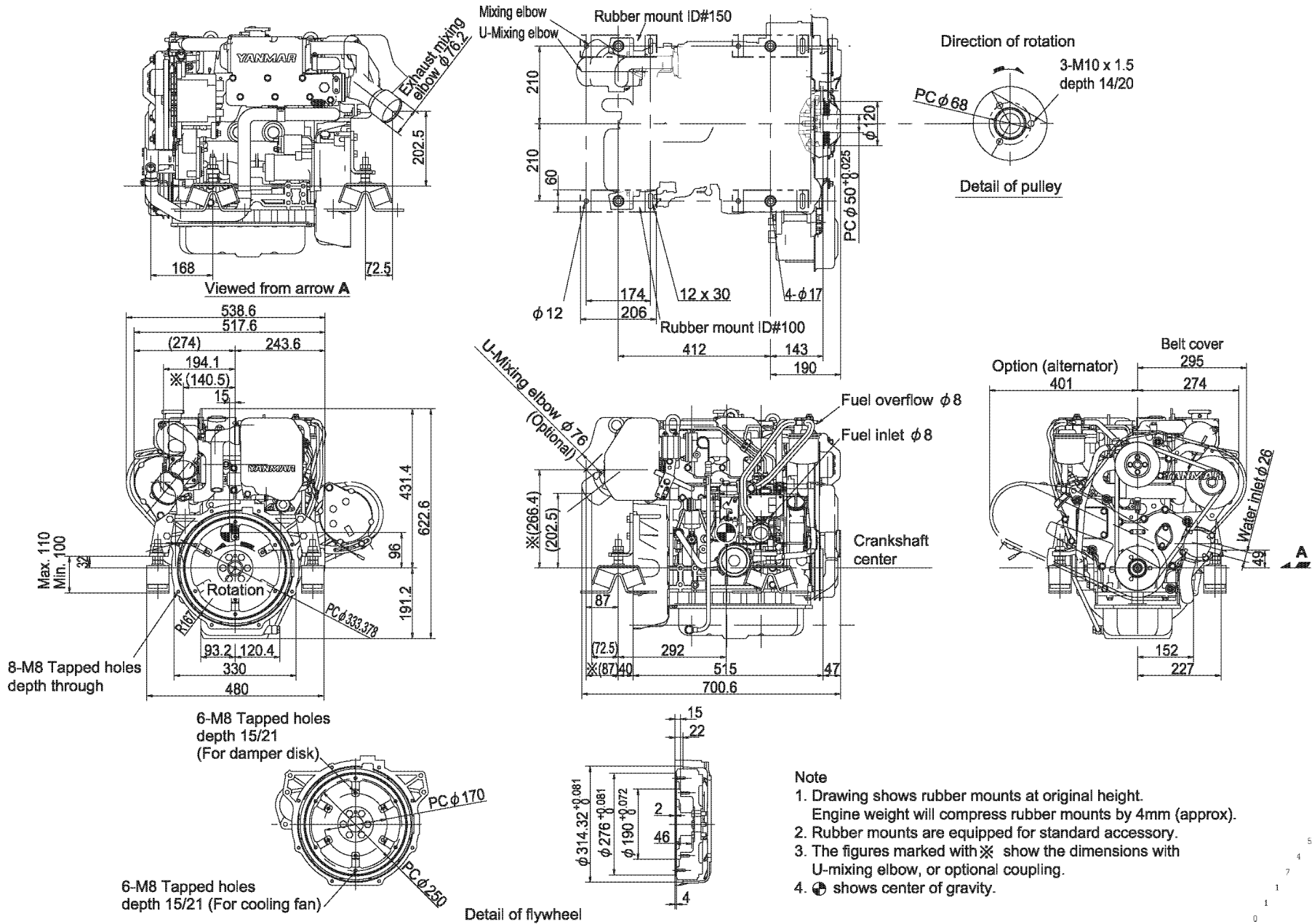

4JH4AE Models

4JH4AE - Inboard Version (ZF30M)

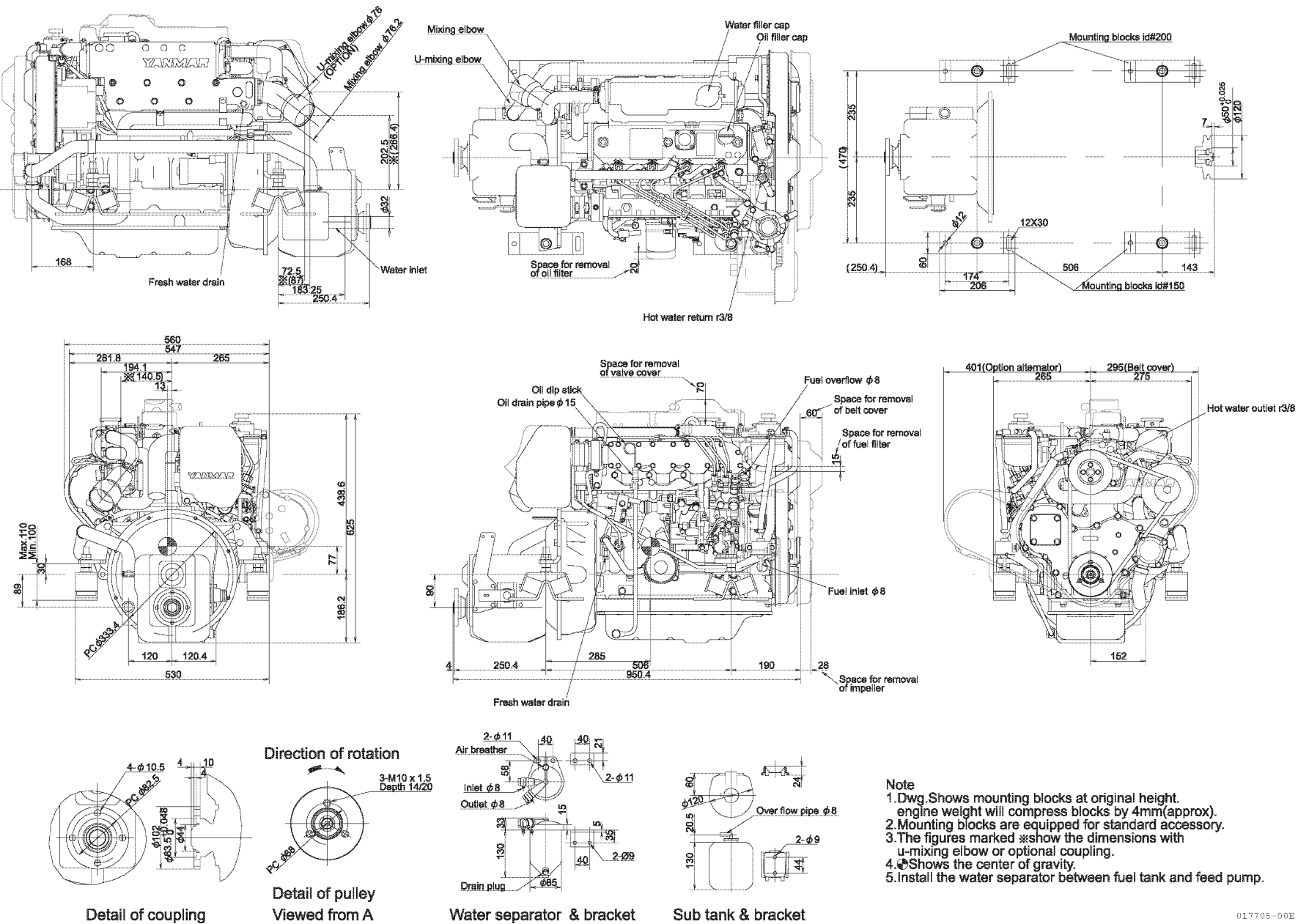

- Note
1. Dwg. Shows mounting blocks at original height. engine weight will compress blocks by 4mm(approx).
 2. Mounting blocks are equipped for standard accessory.
 3. The figures marked ※ show the dimensions with u-mixing elbow or optional coupling.
 4. Ⓞ Shows the center of gravity.
 5. Install the water separator between fuel tank and feed pump.

017705-00B

Figure 3-5

4JH4AE - Inboard Version (KM35A2)

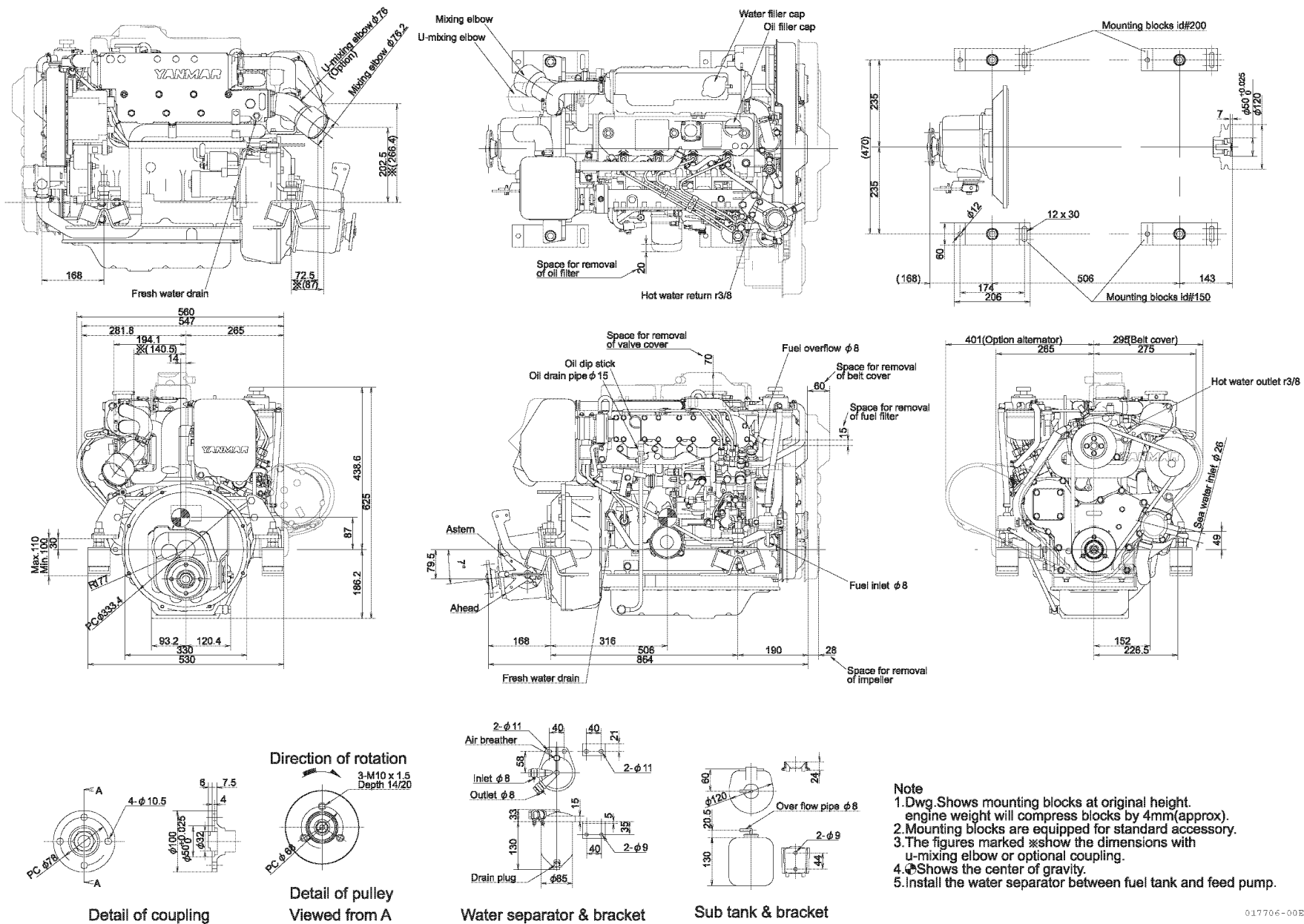

017706-00B

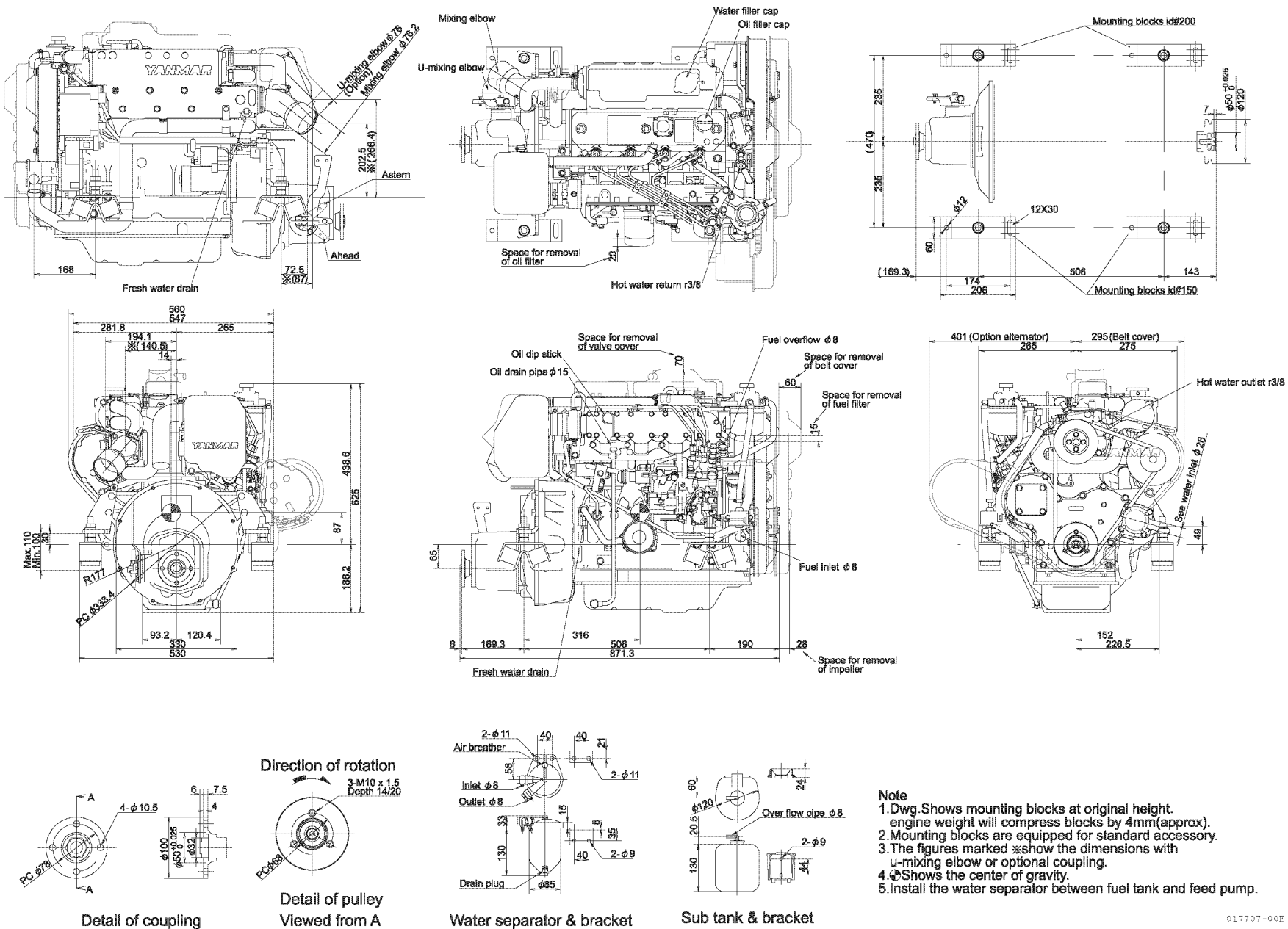
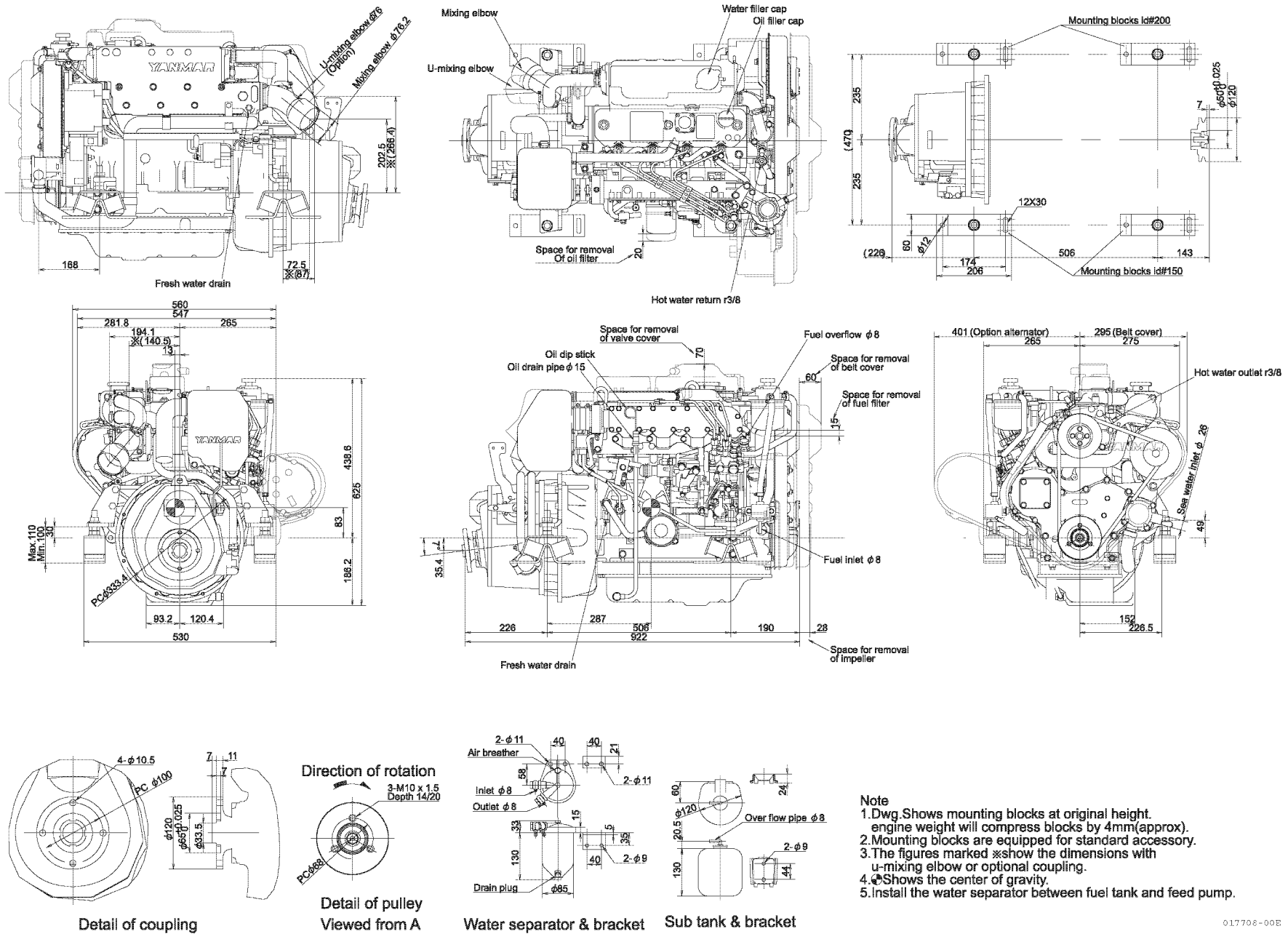

Figure 3-7

4JH4AE - Inboard Version (KM4A1)



- Note**
1. Dwg. Shows mounting blocks at original height. engine weight will compress blocks by 4mm (approx).
 2. Mounting blocks are equipped for standard accessory.
 3. The figures marked ※ show the dimensions with u-mixing elbow or optional coupling.
 4. φ Shows the center of gravity.
 5. Install the water separator between fuel tank and feed pump.

017708-00E

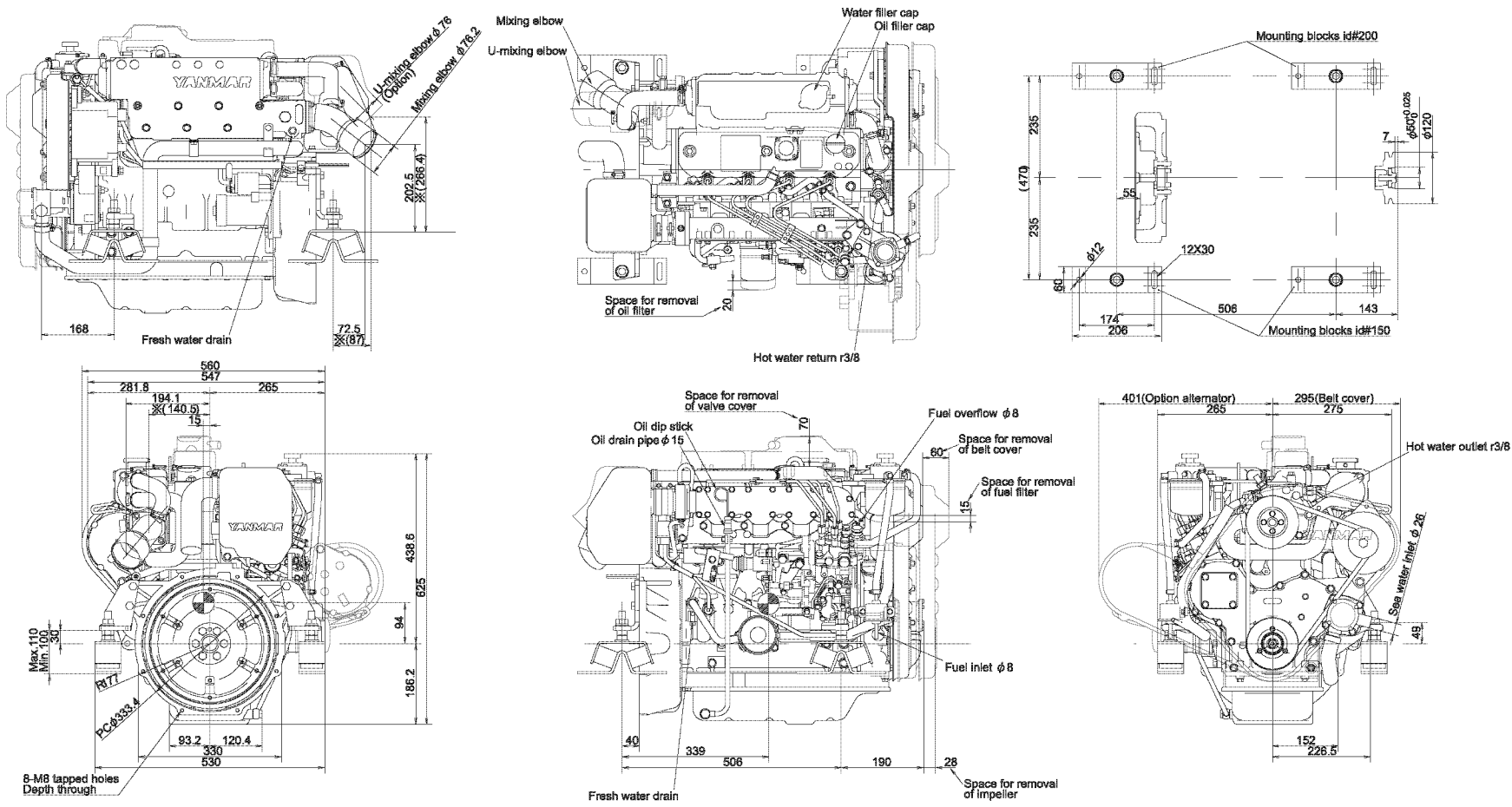

Figure 3-9

- Note
1. Dwg. Shows mounting blocks at original height. engine weight will compress blocks by 4mm(approx).
 2. Mounting blocks are equipped for standard accessory.
 3. The figures marked ※ show the dimensions with u-mixing elbow or optional coupling.
 4. Ⓞ Shows the center of gravity.
 5. Install the water separator between fuel tank and feed pump.

017709-00E

4JH4AE - Sail Drive Version (SD50)

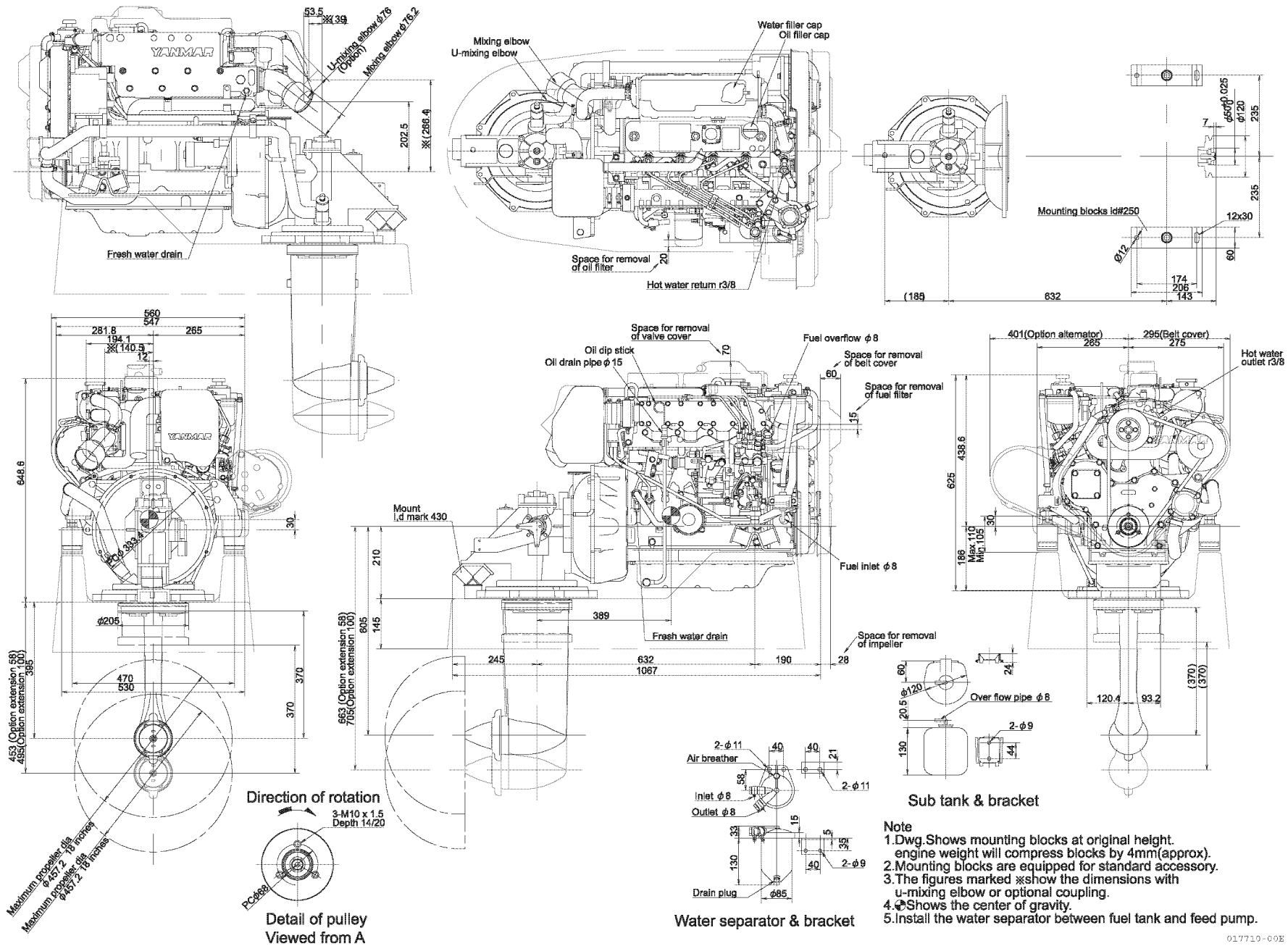

Figure 3-10

- Note**
1. Dwg. Shows mounting blocks at original height. engine weight will compress blocks by 4mm (approx).
 2. Mounting blocks are equipped for standard accessory.
 3. The figures marked * show the dimensions with u-mixing elbow or optional coupling.
 4. φ Shows the center of gravity.
 5. Install the water separator between fuel tank and feed pump.

017710-09E

4JH4-TE Models

4JH4-TE - Inboard Version (ZF30M)

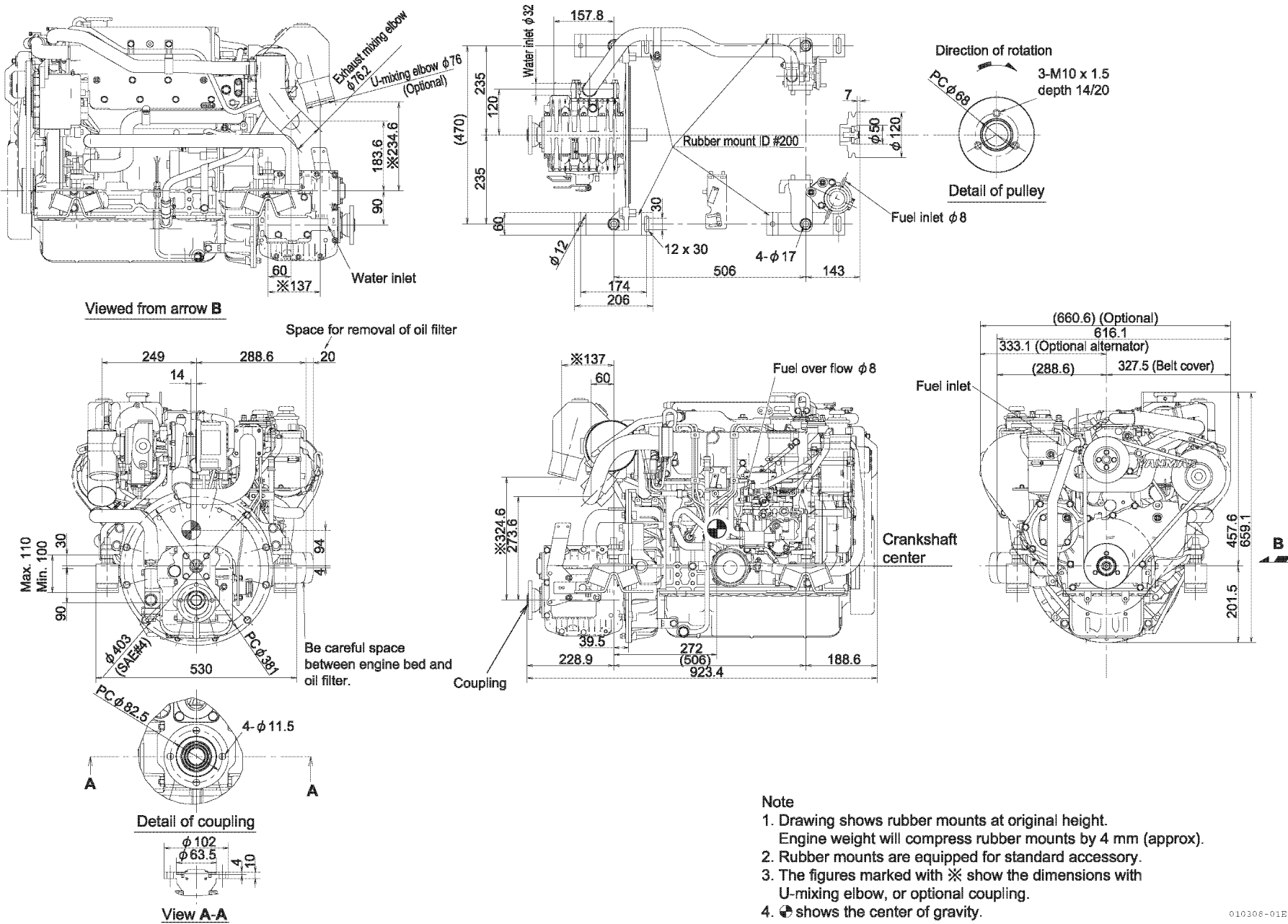

- Note**
1. Drawing shows rubber mounts at original height. Engine weight will compress rubber mounts by 4 mm (approx).
 2. Rubber mounts are equipped for standard accessory.
 3. The figures marked with * show the dimensions with U-mixing elbow, or optional coupling.
 4. Ⓞ shows the center of gravity.

010308-01E

Figure 3-11

4JH4-TE - Inboard Version (KM4A2)

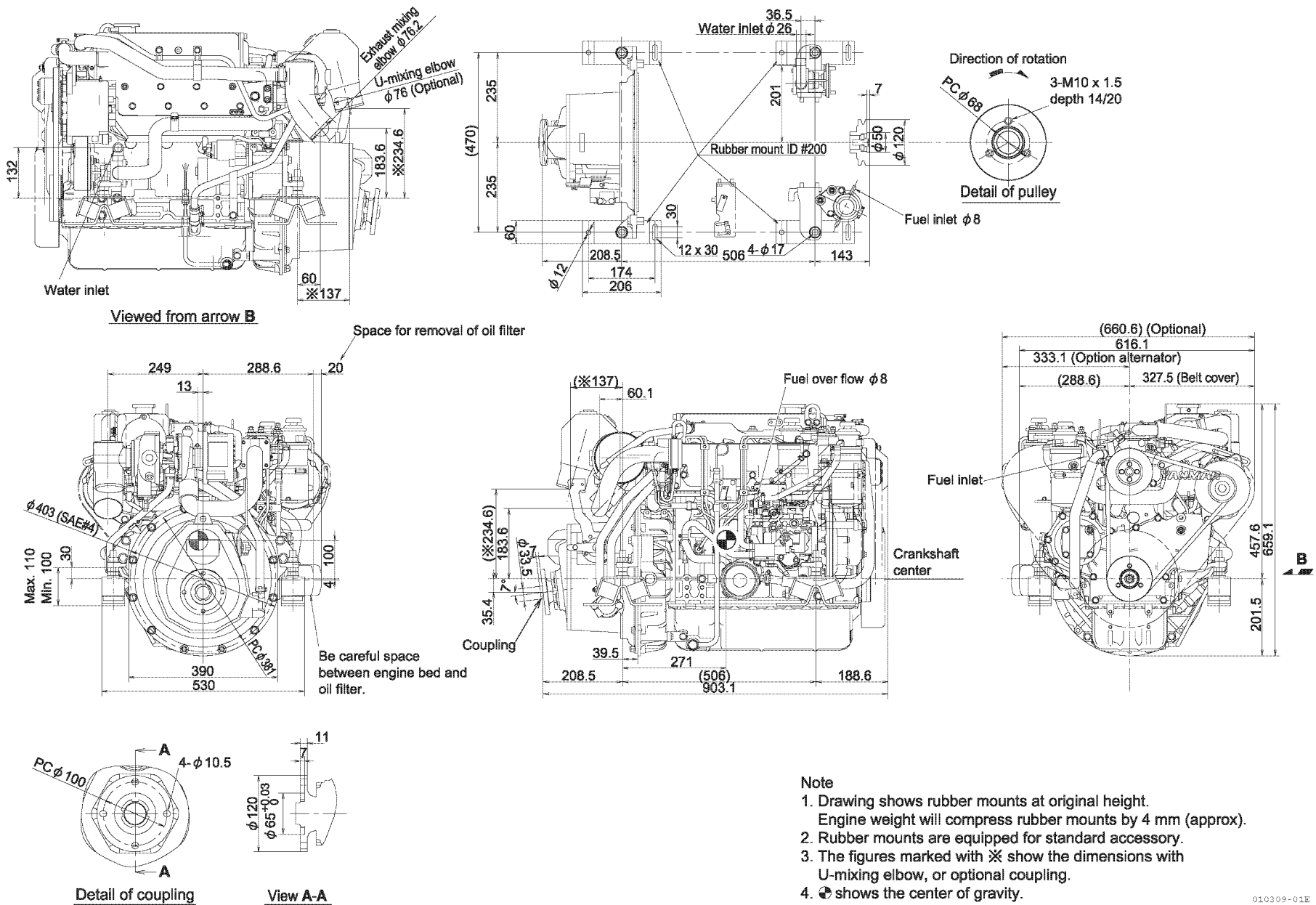

Note

1. Drawing shows rubber mounts at original height. Engine weight will compress rubber mounts by 4 mm (approx).
2. Rubber mounts are equipped for standard accessory.
3. The figures marked with \times show the dimensions with U-mixing elbow, or optional coupling.
4. ϕ shows the center of gravity.

010309-01E

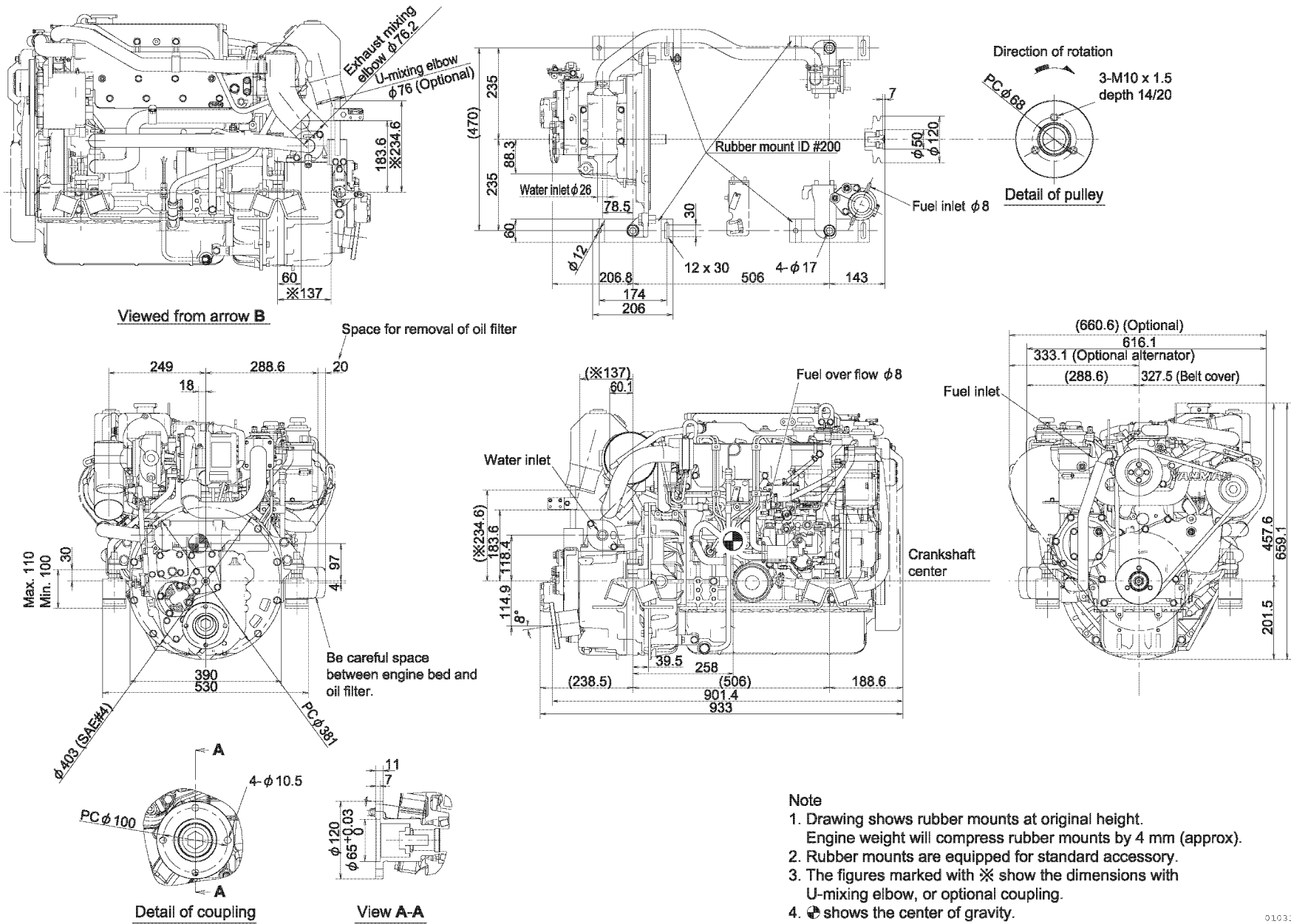

- Note
1. Drawing shows rubber mounts at original height. Engine weight will compress rubber mounts by 4 mm (approx).
 2. Rubber mounts are equipped for standard accessory.
 3. The figures marked with \times show the dimensions with U-mixing elbow, or optional coupling.
 4. \oplus shows the center of gravity.

010310-01E

Figure 3-13

4JH4-TE - Inboard Version (ZF25A)

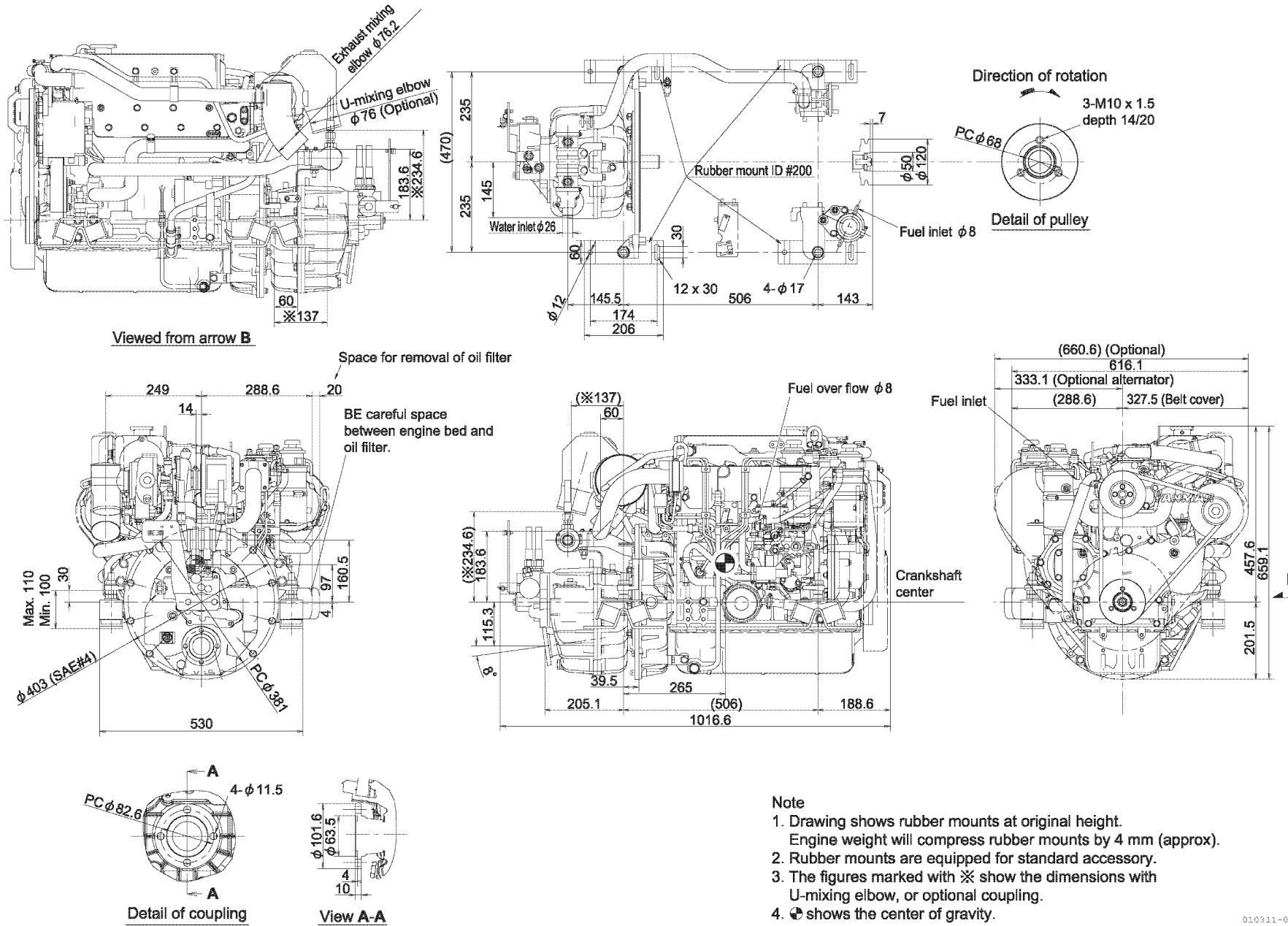

010311-01E

Figure 3-14

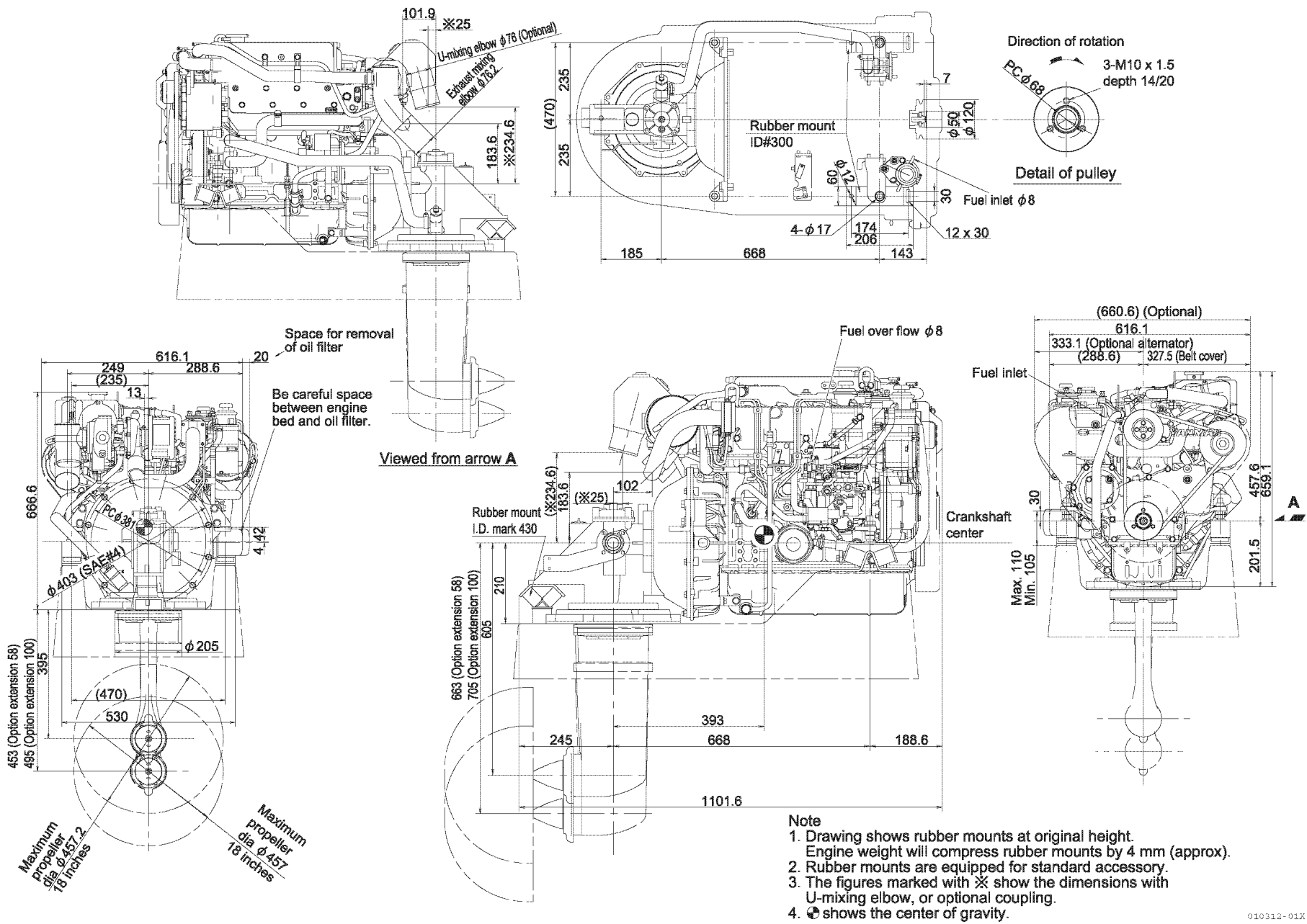

010312-01X

4JH4E-TE - without Marine Gear

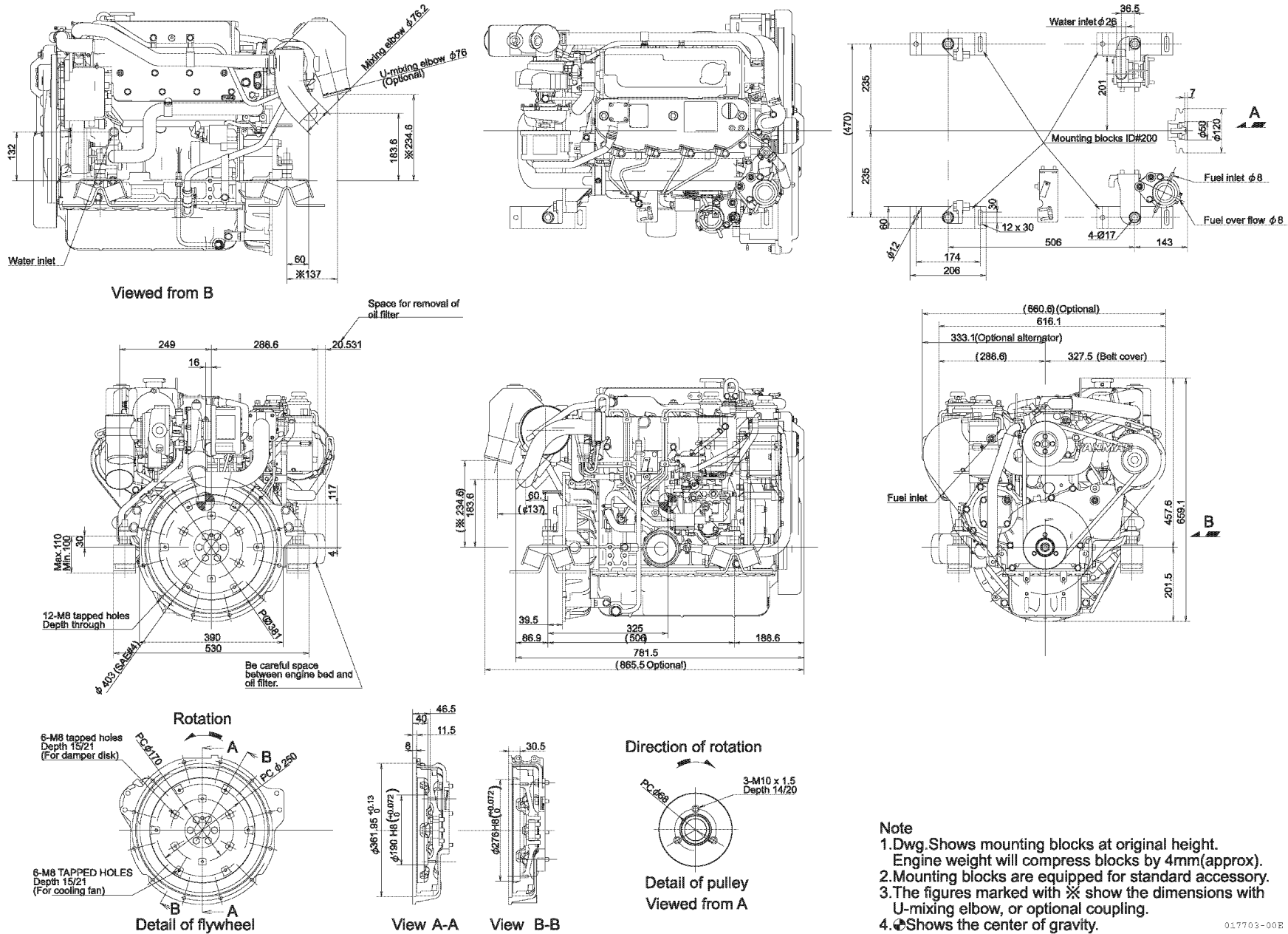

Note

1. Dwg. Shows mounting blocks at original height. Engine weight will compress blocks by 4mm (approx).
2. Mounting blocks are equipped for standard accessory.
3. The figures marked with \approx show the dimensions with U-mixing elbow, or optional coupling.
4. ϕ Shows the center of gravity.

017703-00B

Figure 3-16

4JH4-HTE Models

4JH4-HTE - Inboard Version (ZF30M)

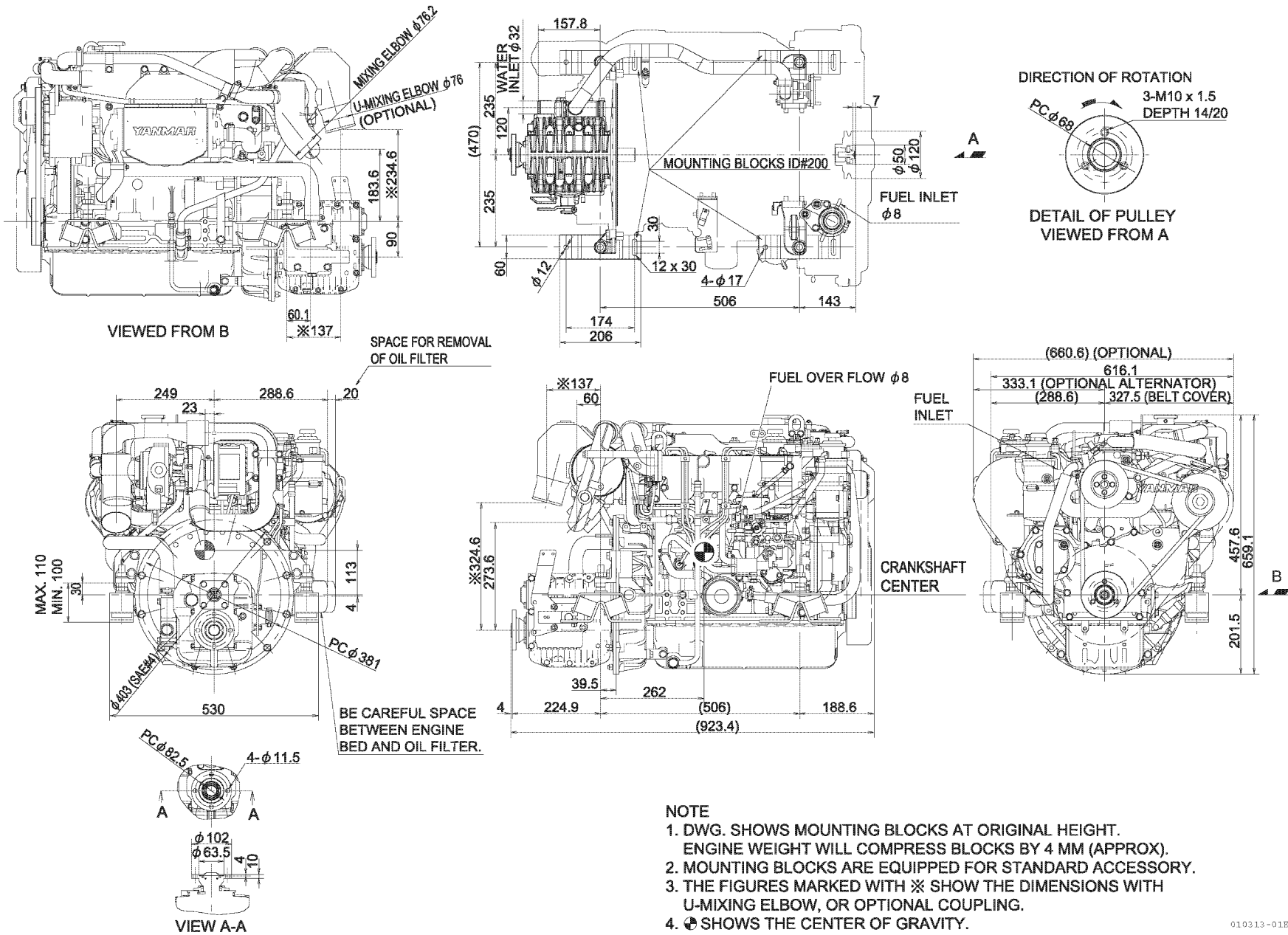

NOTE

1. DWG. SHOWS MOUNTING BLOCKS AT ORIGINAL HEIGHT. ENGINE WEIGHT WILL COMPRESS BLOCKS BY 4 MM (APPROX).
2. MOUNTING BLOCKS ARE EQUIPPED FOR STANDARD ACCESSORY.
3. THE FIGURES MARKED WITH ※ SHOW THE DIMENSIONS WITH U-MIXING ELBOW, OR OPTIONAL COUPLING.
4. ⊙ SHOWS THE CENTER OF GRAVITY.

010313-01E

Figure 3-17

4JH4-HTE - Inboard Version (KM4A2)

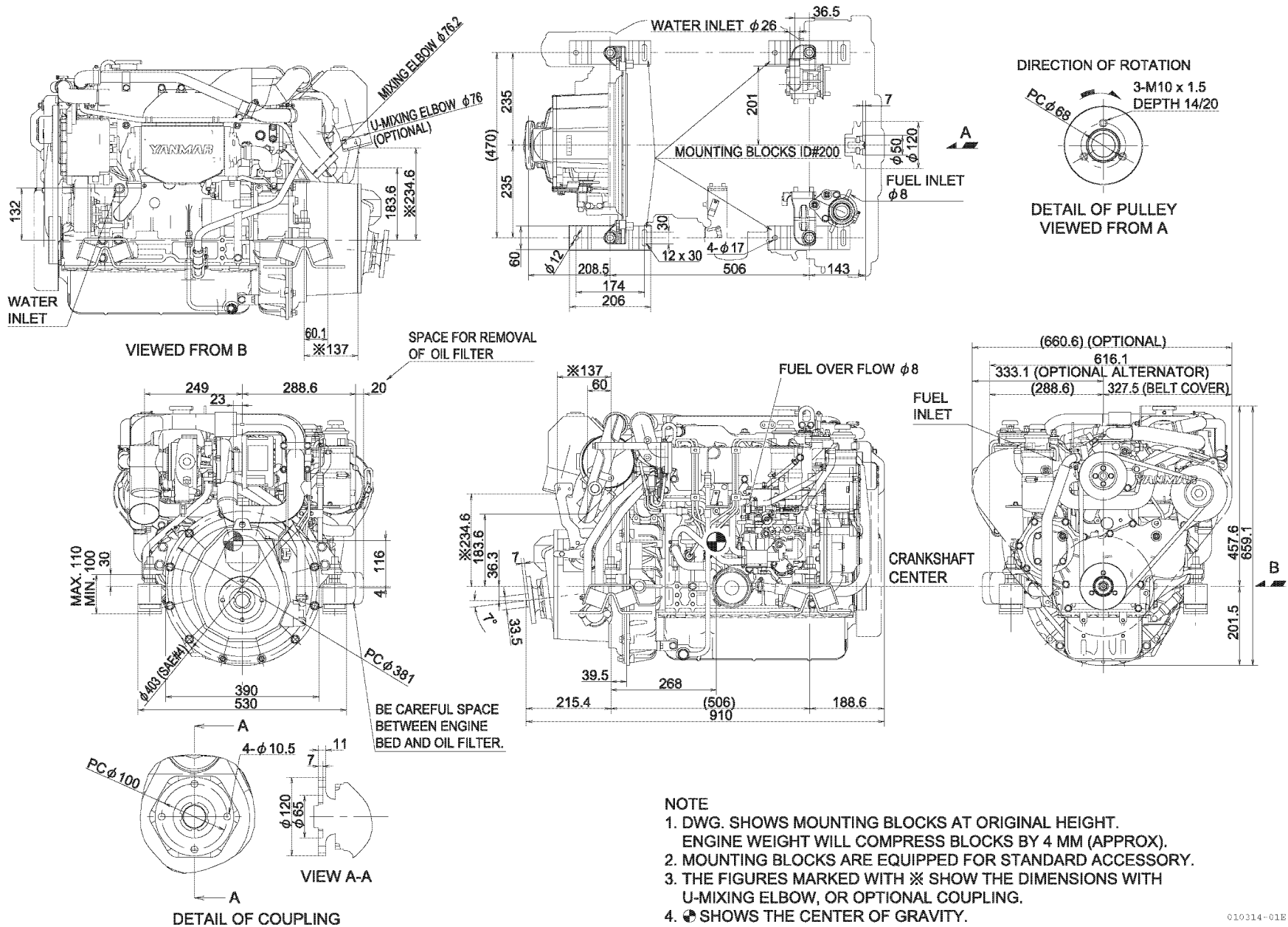

010314-01E

Figure 3-18

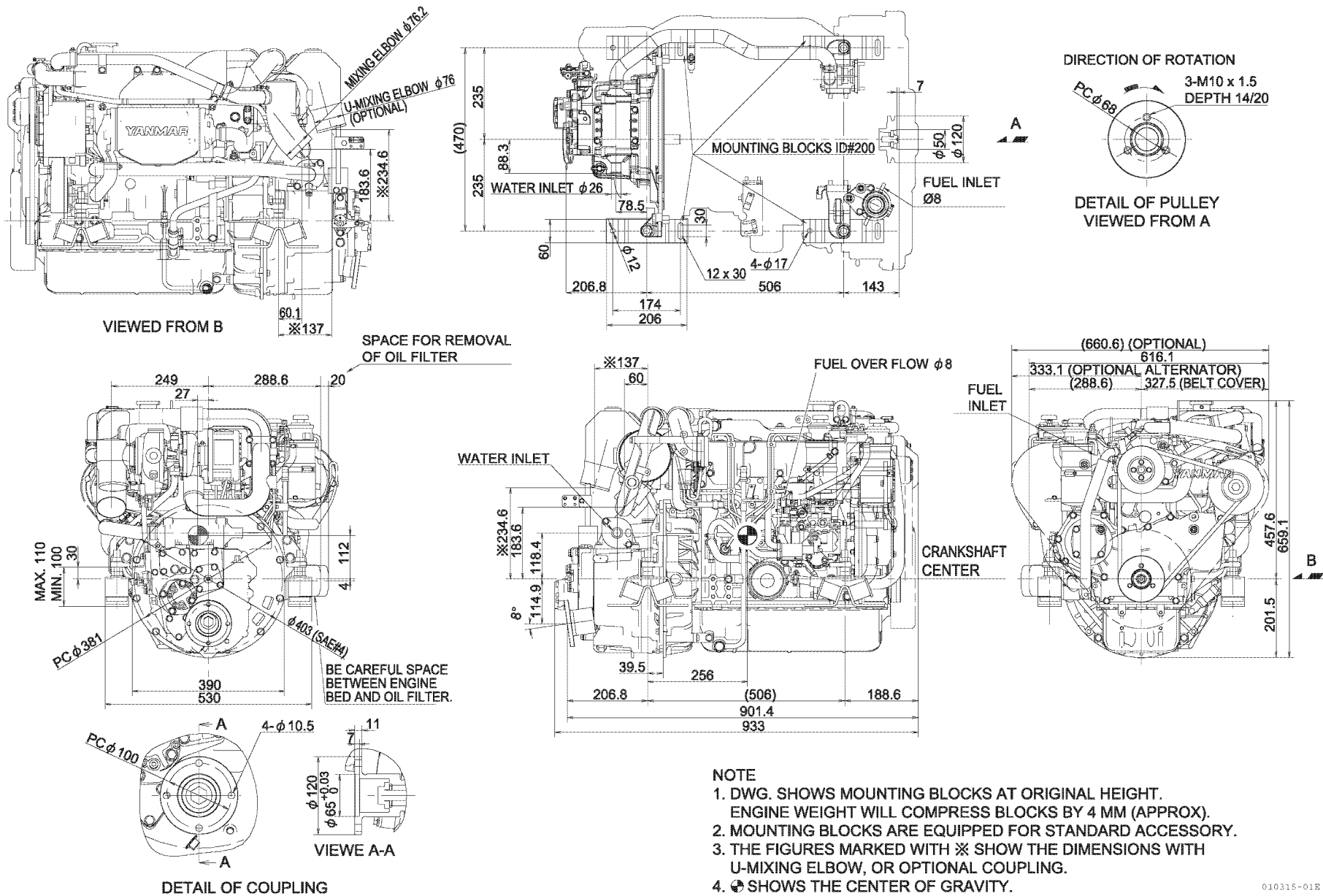

010315-01B

Figure 3-19

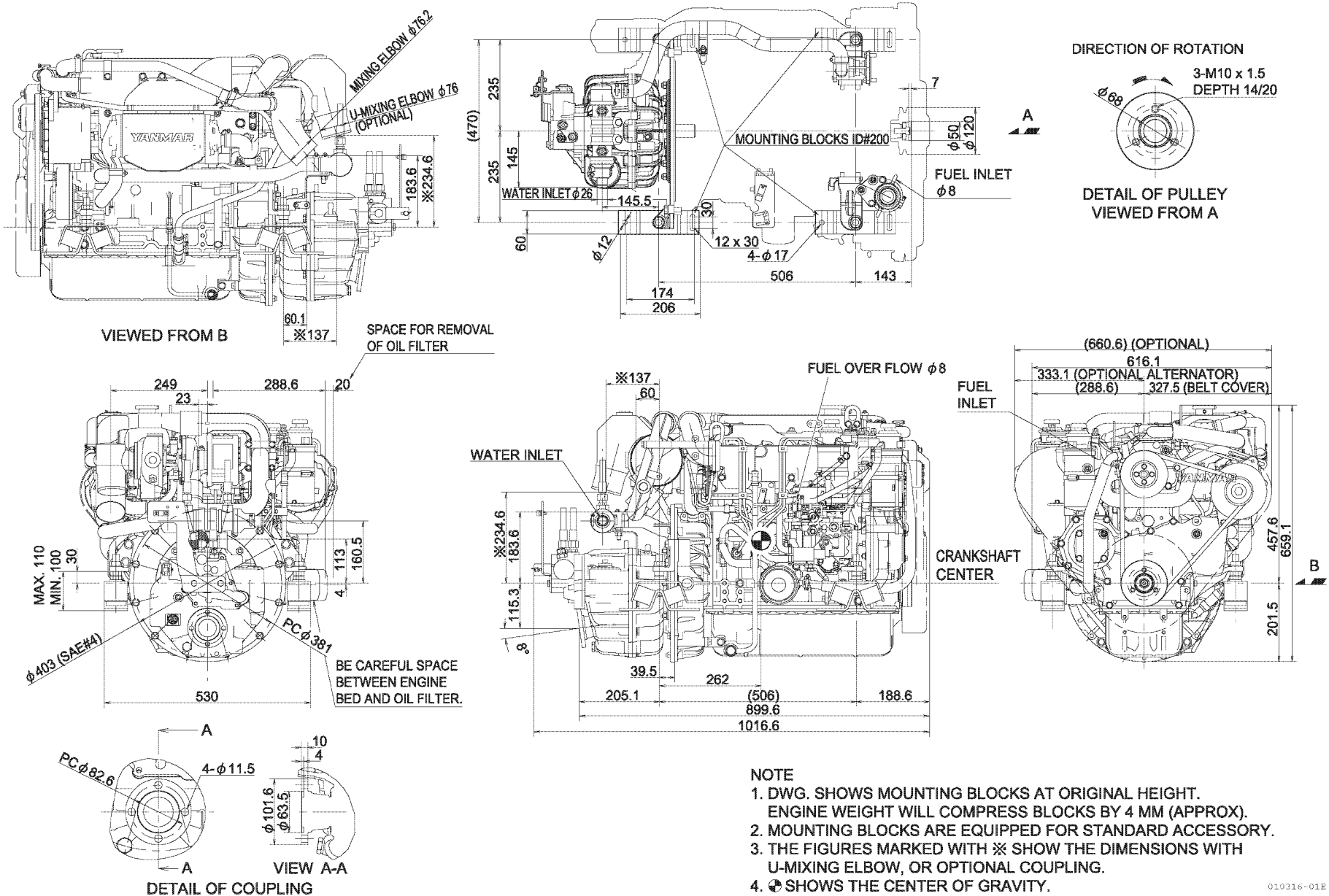

010316-01E

Figure 3-20

4JH4E-HTE - without Marine Gear

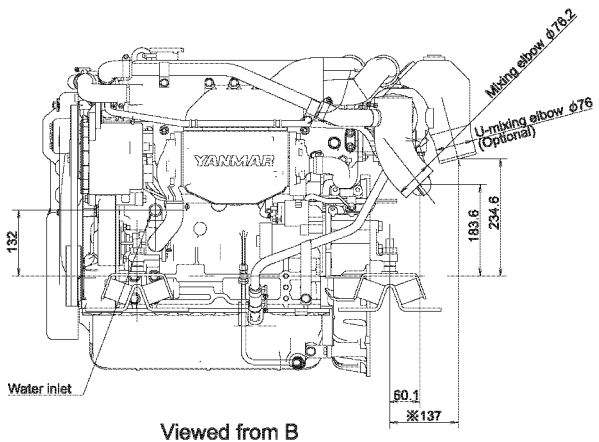

Viewed from B

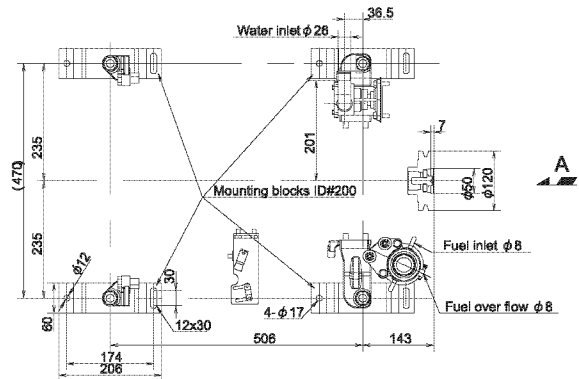
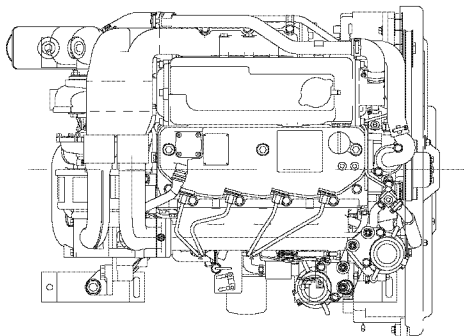

A

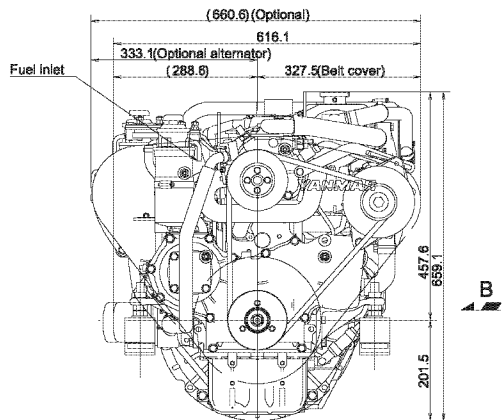
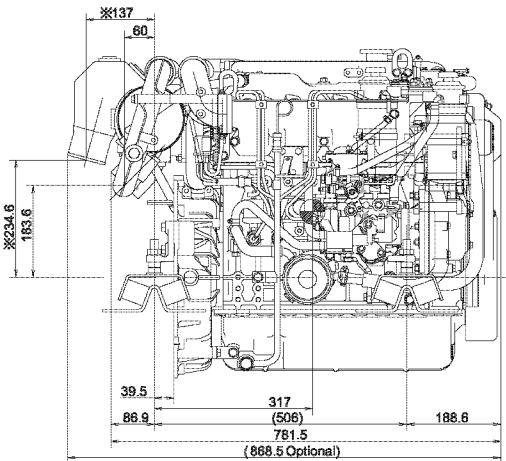
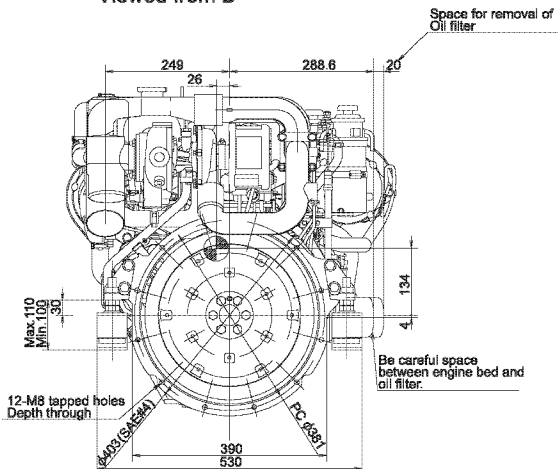

B

Figure 3-21

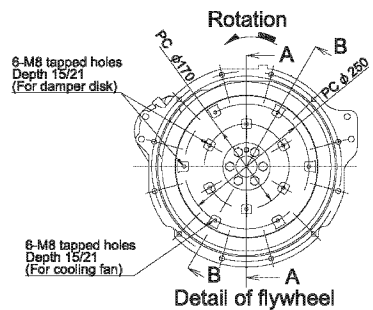

Detail of flywheel

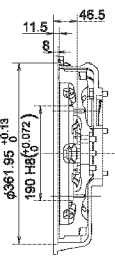

View A-A

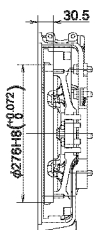

View B-B

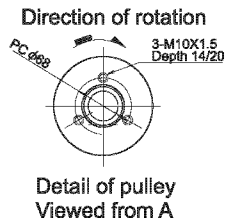

Detail of pulley Viewed from A

Note

1. Dwg. Shows mounting blocks at original height. engine weight will compress blocks by 4mm (approx).
2. Mounting blocks are equipped for standard accessory.
3. The figures marked with ※ show the dimensions with u-mixing elbow, or optional coupling.
4. Ⓞ Shows the center of gravity.

017794-002

ENGINE PIPING DIAGRAMS

3JH4E Models

3JH4E (KM35P, KM35A)

Marks of piping	
	Screw joint (Union)
	Flange joint
	Eye joint
	Insertion joint
	Drill hole
	Cooling fresh water piping
	Cooling seawater piping
	Lubricating oil piping
	Fuel oil piping

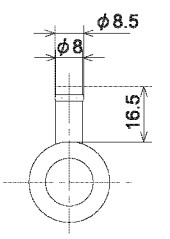
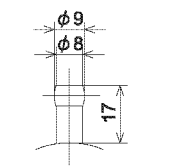
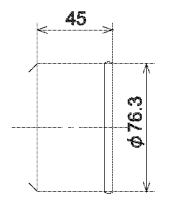
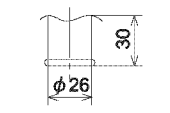
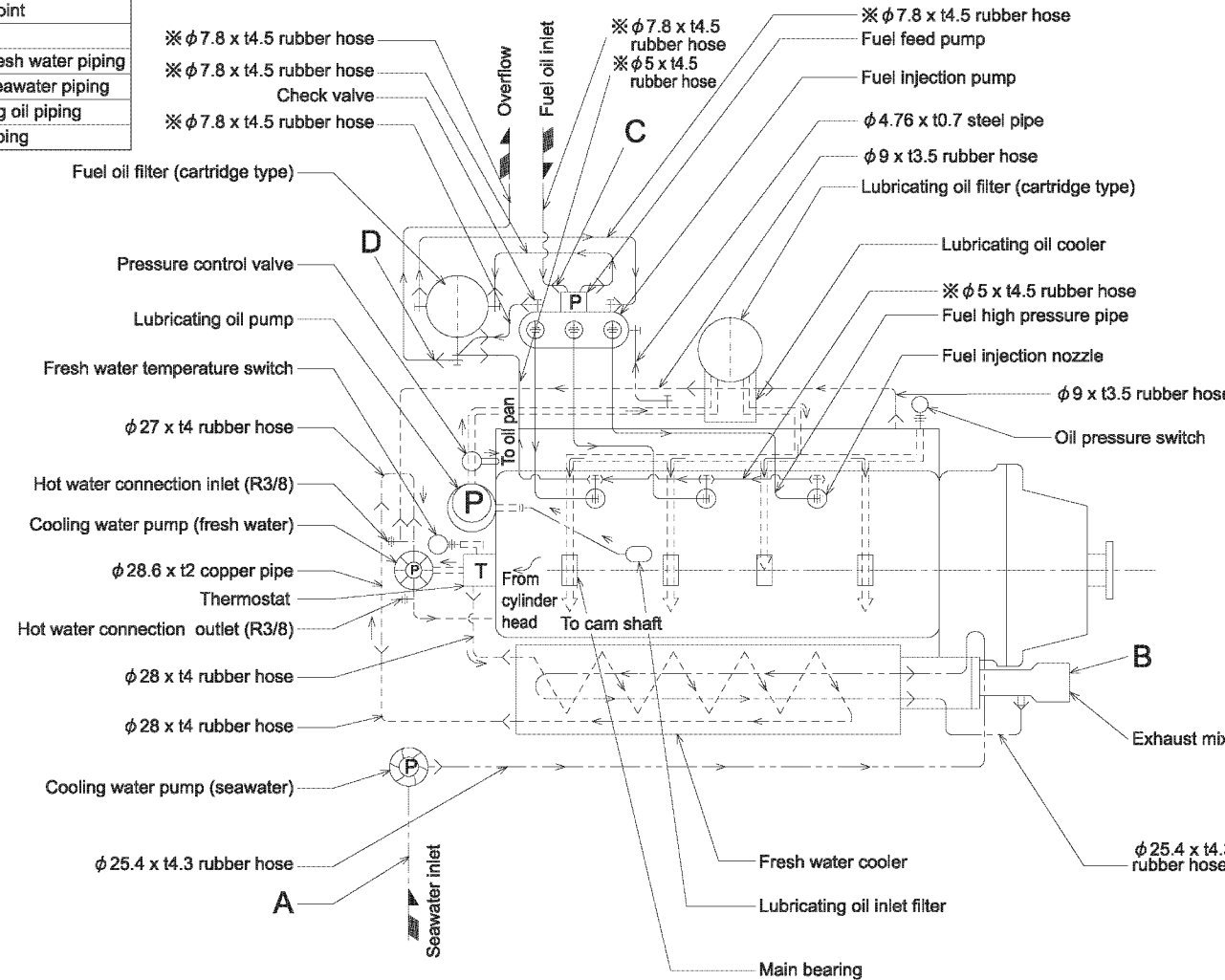
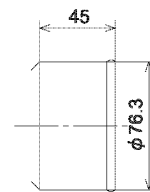
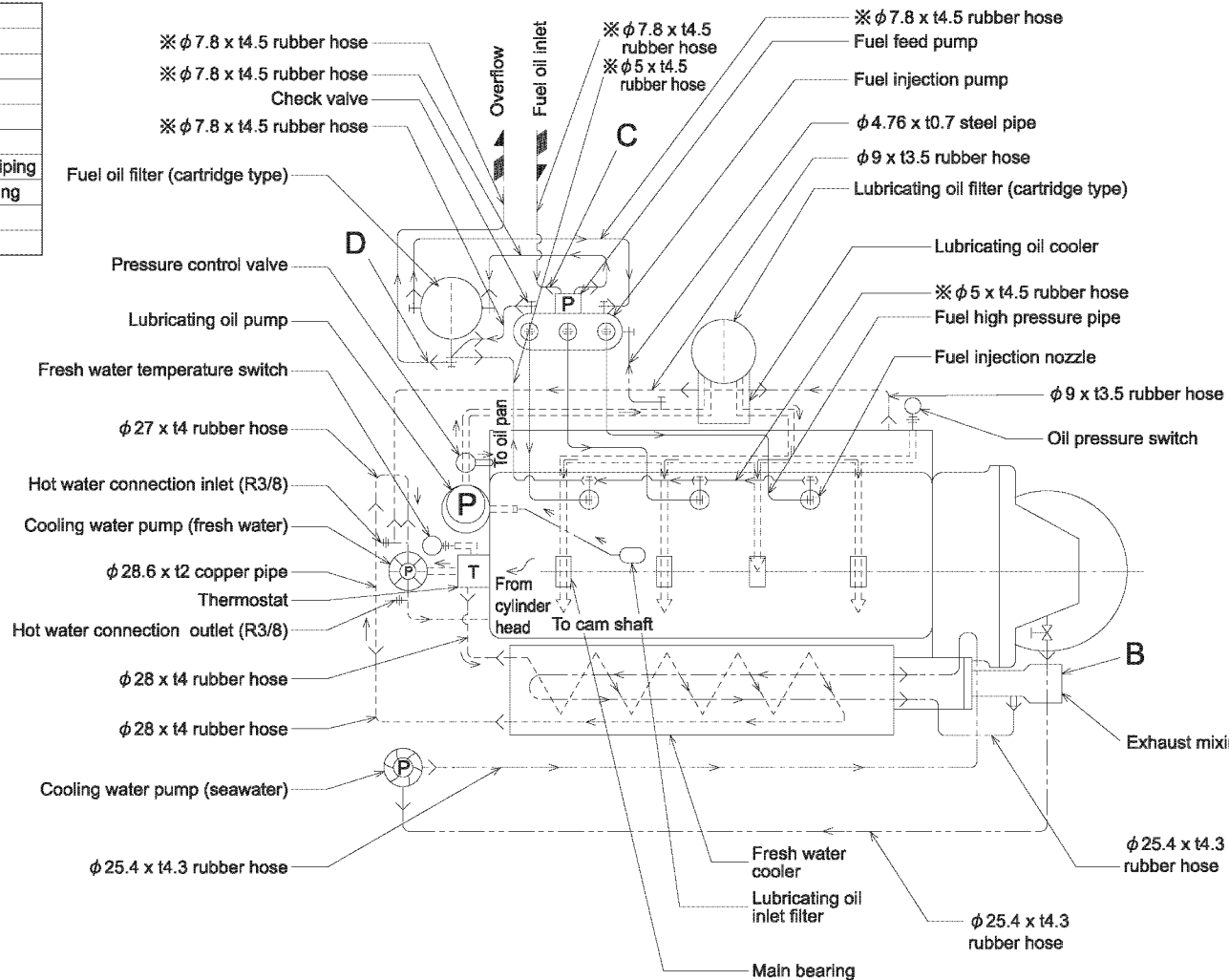

Figure 3-22

- Notes
1. Dimension of steel pipe : outer dia. x thickness.
Dimension of rubber pipe : inner dia. x thickness.
 2. Fuel rubber pipes (marked ※) satisfy EN/ISO7840.

010317-01X

Marks of piping	
	Screw joint (Union)
	Flange joint
	Eye joint
	Insertion joint
	Drill hole
	Cooling fresh water piping
	Cooling seawater piping
	Lubricating oil piping
	Fuel oil piping



Detail of part B

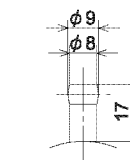

Detail of part C

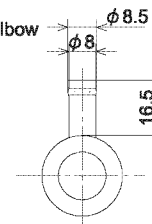

Detail of part D

015032-01E

Notes

1. Dimension of steel pipe : outer dia. x thickness.
Dimension of rubber pipe : inner dia. x thickness.
2. Fuel rubber pipes (marked ※) satisfy EN/ISO7840.

Figure 3-23

4JH4AE Models

4JH4AE (ZF30M)

Marks of piping	
RH	Rubber hose
SGP STS	Steel pipe
C1201T	Copper pipe
⊕	(Union) Screw joint
⊕	Flange joint
+	Eye joint
—<	Insertion joint
—	Drill hole
—	Cooling fresh Water piping
—	Cooling sea Water piping
—	Lub.Oil piping
—	Fuel oil piping

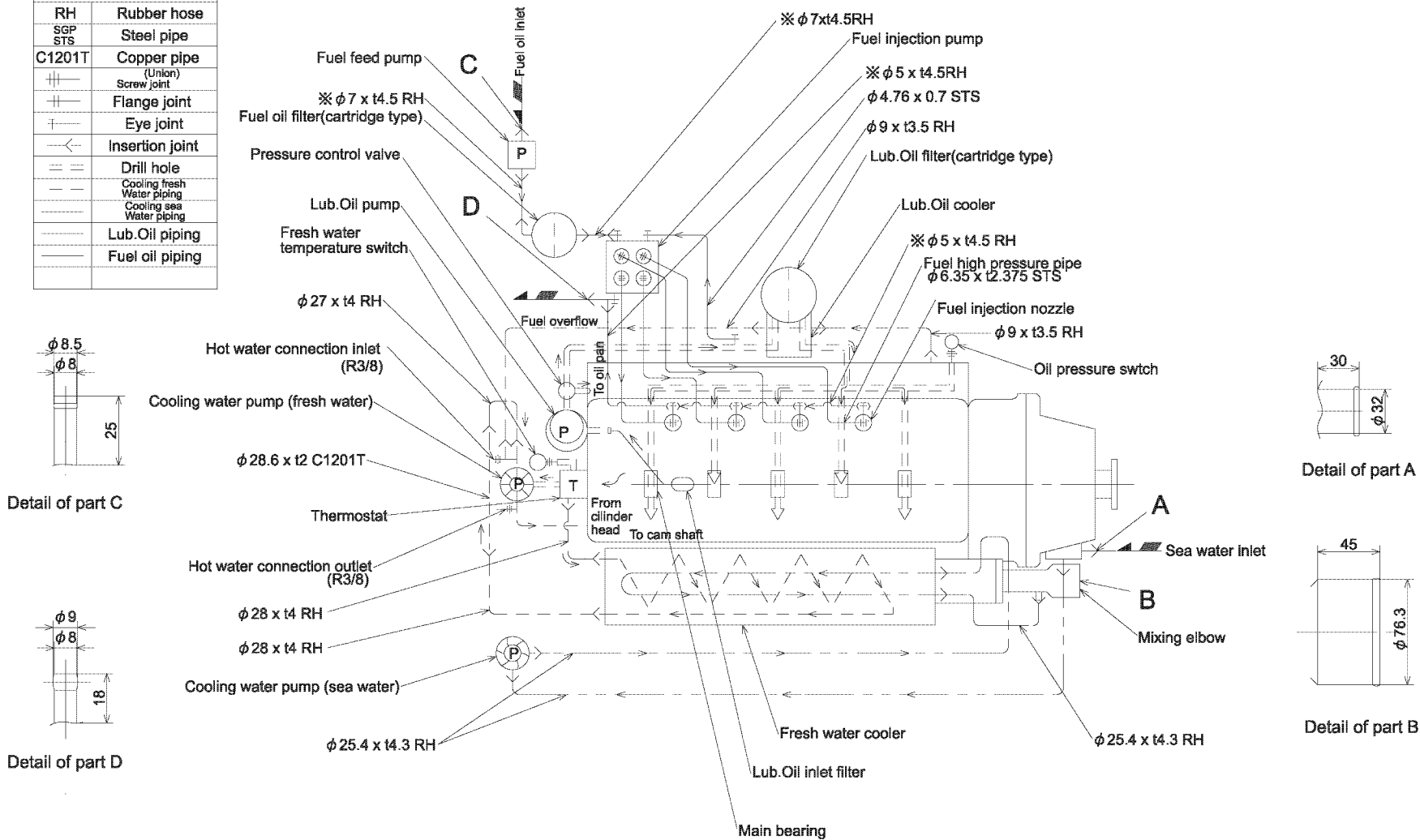

NOTES
 1. DIMENSION OF STEEL PIPE: OUTER DIA. X THICKNESS
 DIMENSION OF RUBBER PIPE: INNER DIA. X THICKNESS
 2. FUEL RUBBER PIPES (MARKED ※) SATISFY EN/ISO7840.
 DETAILS FOLLOW SPECIFICATIONS KSC4.7.

017701-00E

Figure 3-24

Marks of piping	
RH	Rubber hose
SGP STS	Steel pipe
C1201T	Copper pipe
⊕	Union Screw joint
⊕	Flange joint
⊕	Eye joint
⊕	Insertion joint
⊕	Drill hole
⊕	Cooling fresh Water piping
⊕	Cooling sea Water piping
⊕	Lub.Oil piping
⊕	Fuel oil piping

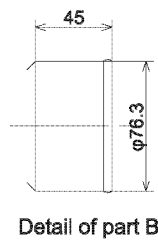
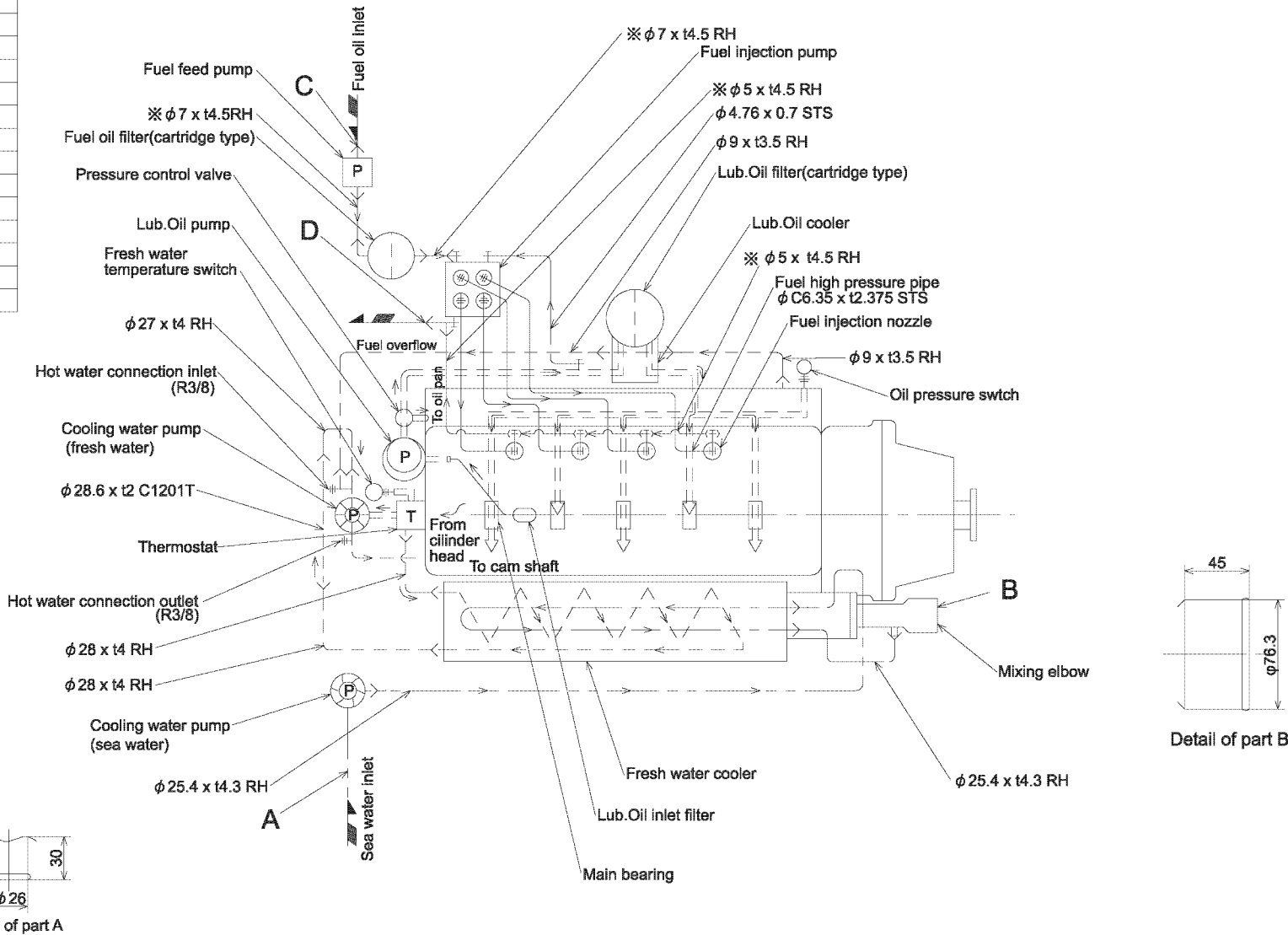
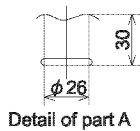
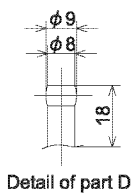
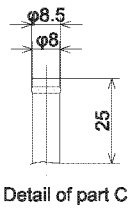

Notes
 1. Dimension of steel pipe: outer dia. X thickness
 Dimension of rubber pipe: inner dia. X thickness
 2. Fuel rubber pipes (marked ※) satisfy en/iso7840.

017699-00E

Figure 3-25

Marks of piping	
RH	Rubber hose
SGP STS	Steel pipe
C1201t	Copper pipe
— — —	(Union) Screw joint
— — —	Flange joint
— — —	Eye joint
— — —	Insertion joint
— — —	Drill hole
— — —	Cooling fresh Water piping
— — —	Cooling sea Water piping
— — —	Lub.Oil piping
— — —	Fuel oil piping

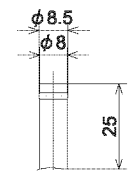

Detail of part C

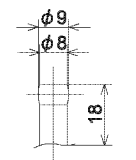

Detail of part D

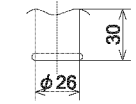

Detail of part A

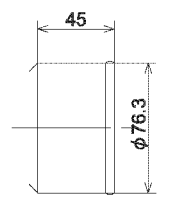
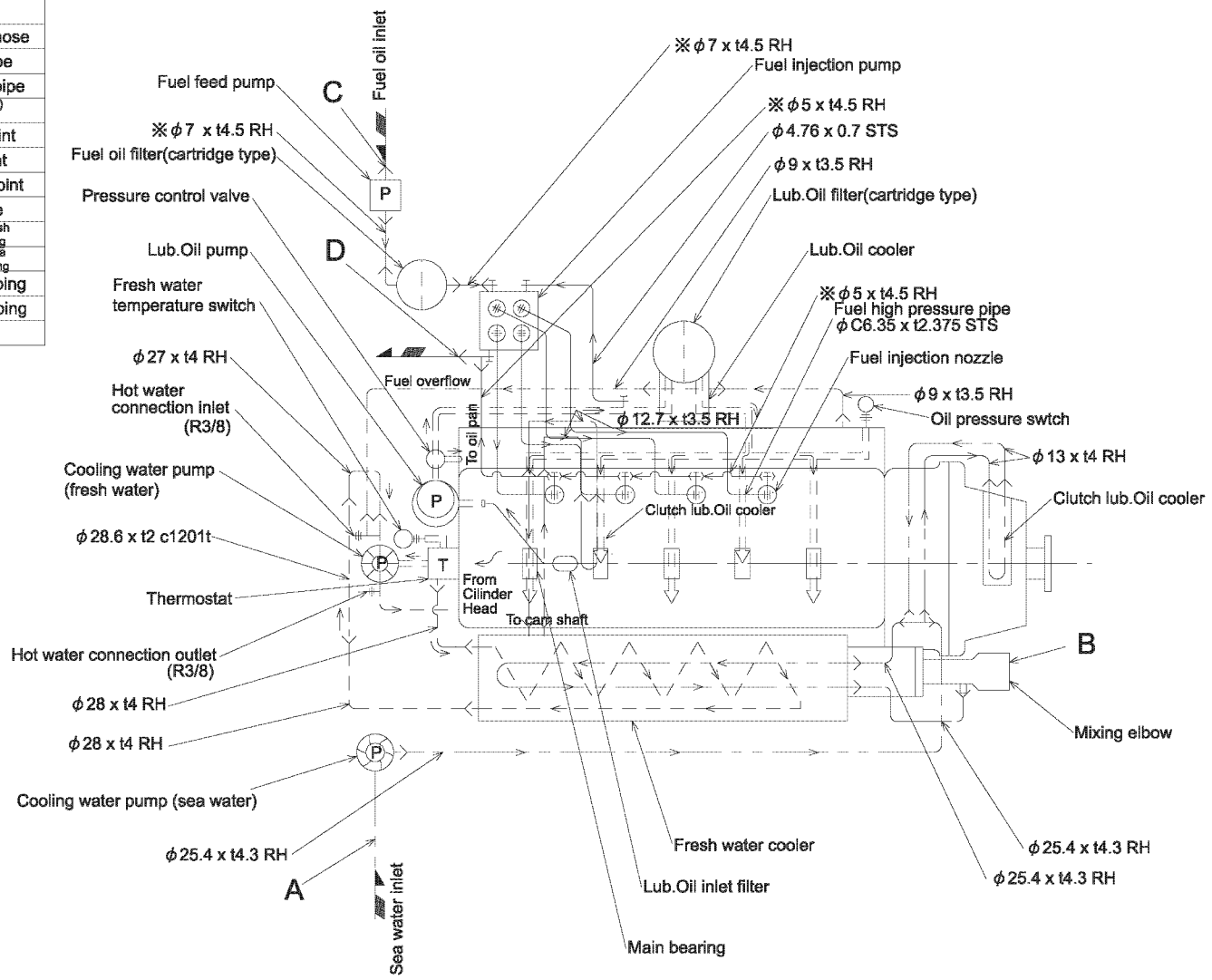

Detail of part B

- Notes
1. Dimension of steel pipe: outer dia. X thickness
Dimension of rubber pipe: inner dia. X thickness
 2. Fuel rubber pipes (marked ※) satisfy en/iso7840.
Details follow specifications ksc4.7.

017700-09E

Figure 3-26

Marks of piping	
RH	Rubber hose
SGP STS	Steel pipe
C1201T	Copper pipe
(Union)	Screw joint
+	Flange joint
+	Eye joint
←	Insertion joint
=	Drill hole
- - -	Cooling fresh Water piping
- - -	Cooling sea Water piping
- - -	Lub.Oil piping
- - -	Fuel oil piping

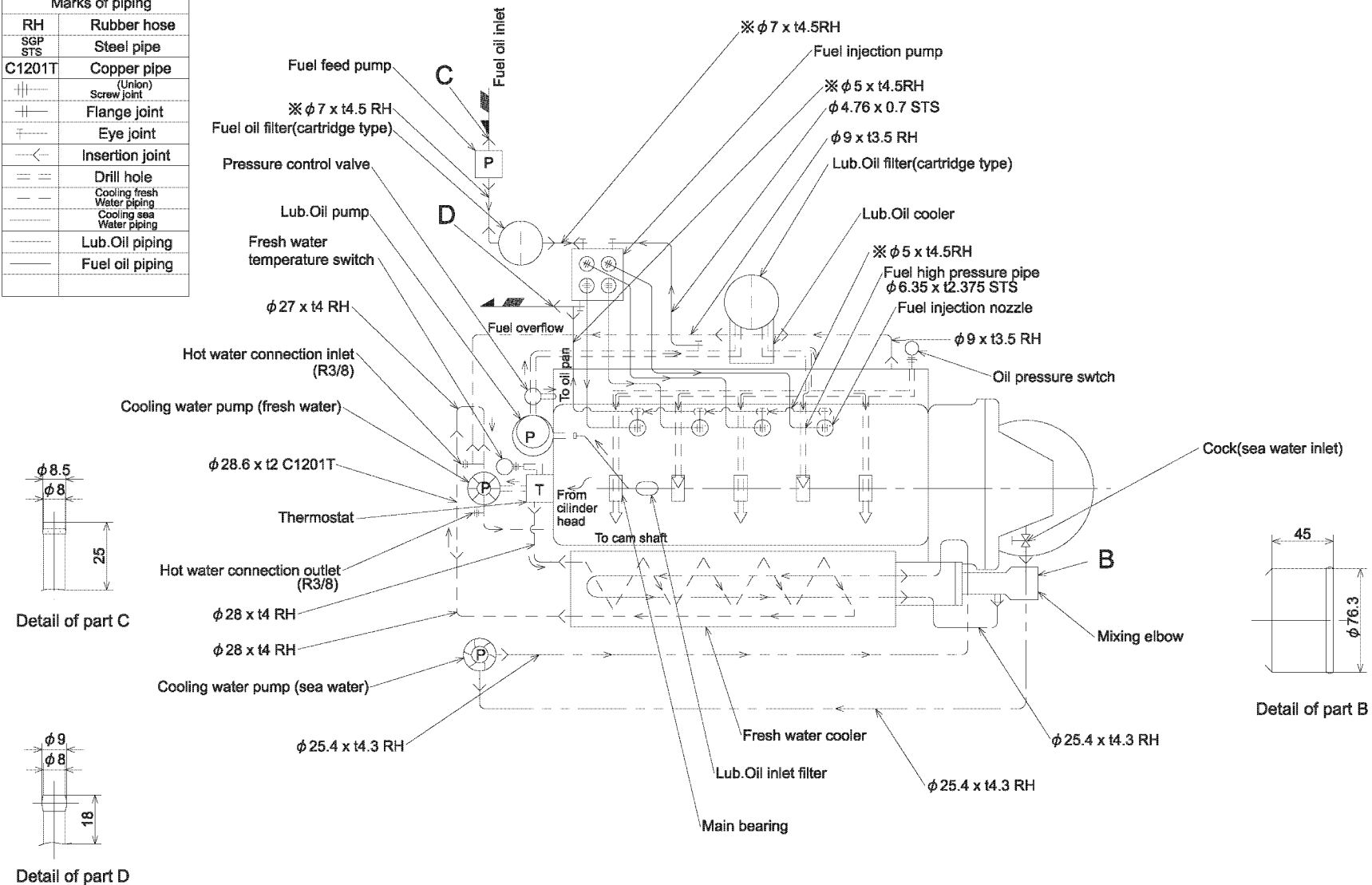

NOTES
 1.DIMENSION OF STEELPIPE:OUTER DIA.XTHICKNESS
 DIMENSION OF RUBBER PIPE:INNER DIA.XTHICKNESS
 2.FUEL RUBBER PIPES(MARKED※) SATISFY EN/ISO7840.
 DETAILS FOLLOW SPECIFICATIONS KSC4.7.

017700-00E

4JH4-TE Models

4JH4-TE (KM4A2)

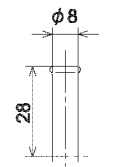

Detail of part A

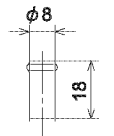

Detail of part B

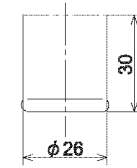

Detail of part C

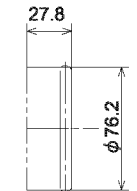

Detail of part D

015037-01E

Marks of piping	
	Screw joint (Union)
	Flange joint
	Eye joint
	Insertion joint
	Drill hole
	Cooling fresh water piping
	Cooling seawater piping
	Lubricating oil piping
	Fuel oil piping

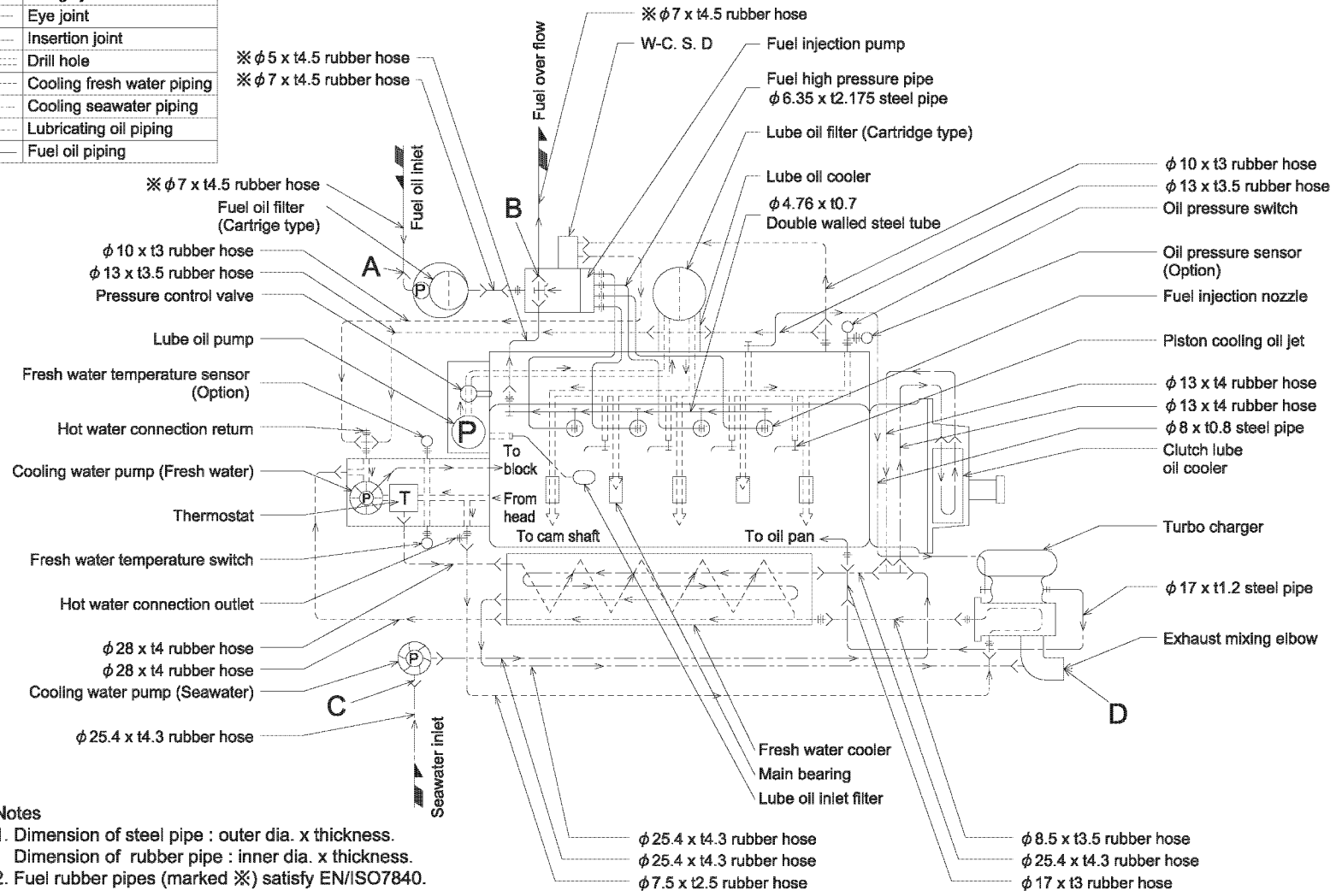

Notes

1. Dimension of steel pipe : outer dia. x thickness.
Dimension of rubber pipe : inner dia. x thickness.
2. Fuel rubber pipes (marked ※) satisfy EN/ISO7840.

Figure 3-28

Marks of piping	
	Screw joint (Union)
	Flange joint
	Eye joint
	Insertion joint
	Drill hole
	Cooling fresh water piping
	Cooling seawater piping
	Lubricating oil piping
	Fuel oil piping

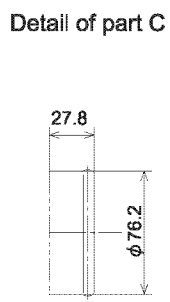
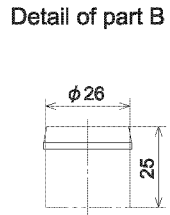
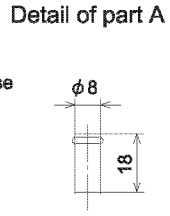
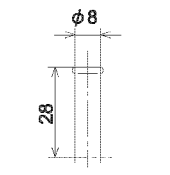
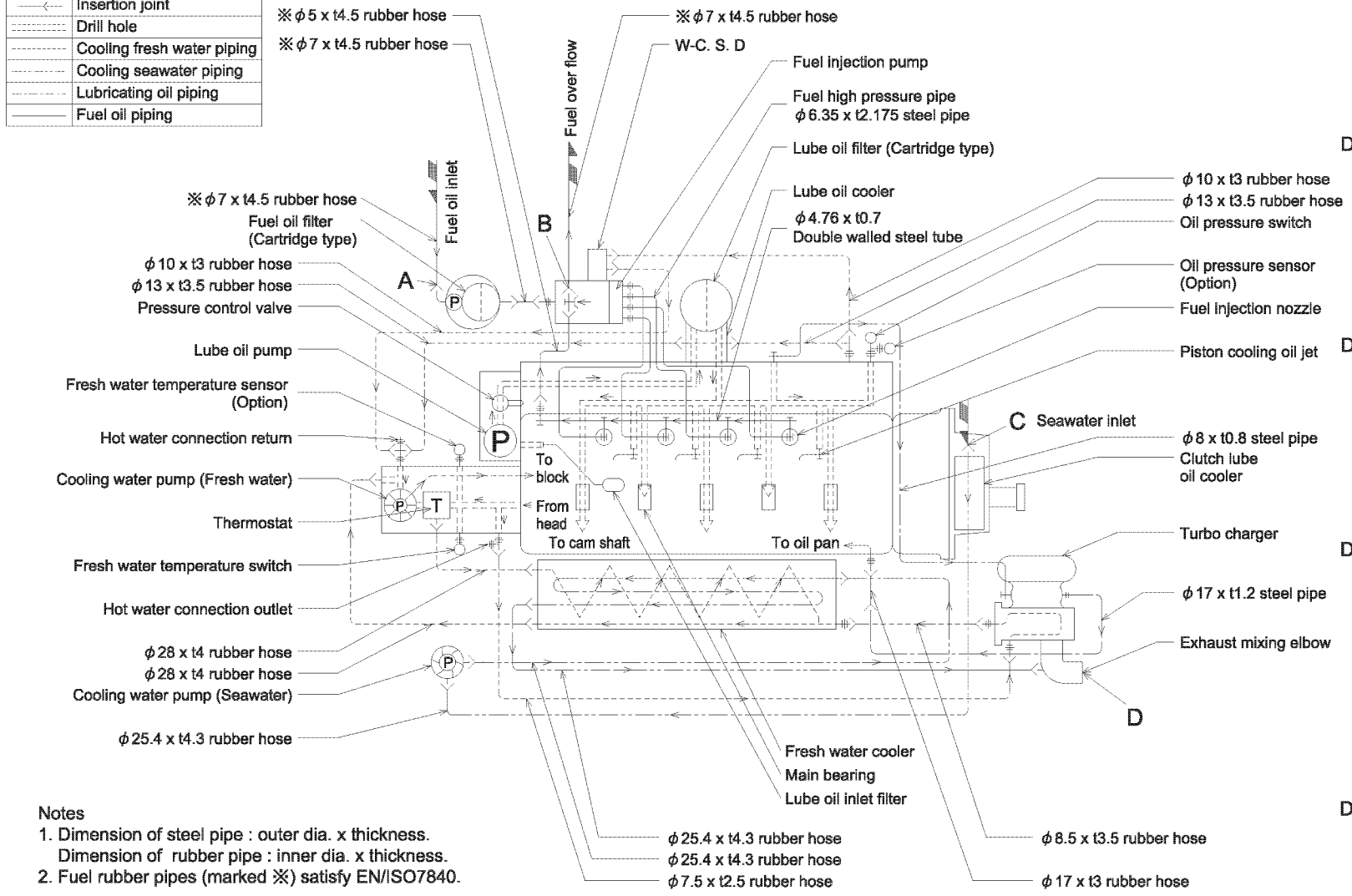

- Notes
1. Dimension of steel pipe : outer dia. x thickness.
Dimension of rubber pipe : inner dia. x thickness.
 2. Fuel rubber pipes (marked ※) satisfy EN/ISO7840.

015038-01E

Figure 3-29

Marks of piping	
	Screw joint (Union)
	Flange joint
	Eye joint
	Insertion joint
	Drill hole
	Cooling fresh water piping
	Cooling seawater piping
	Lubricating oil piping
	Fuel oil piping

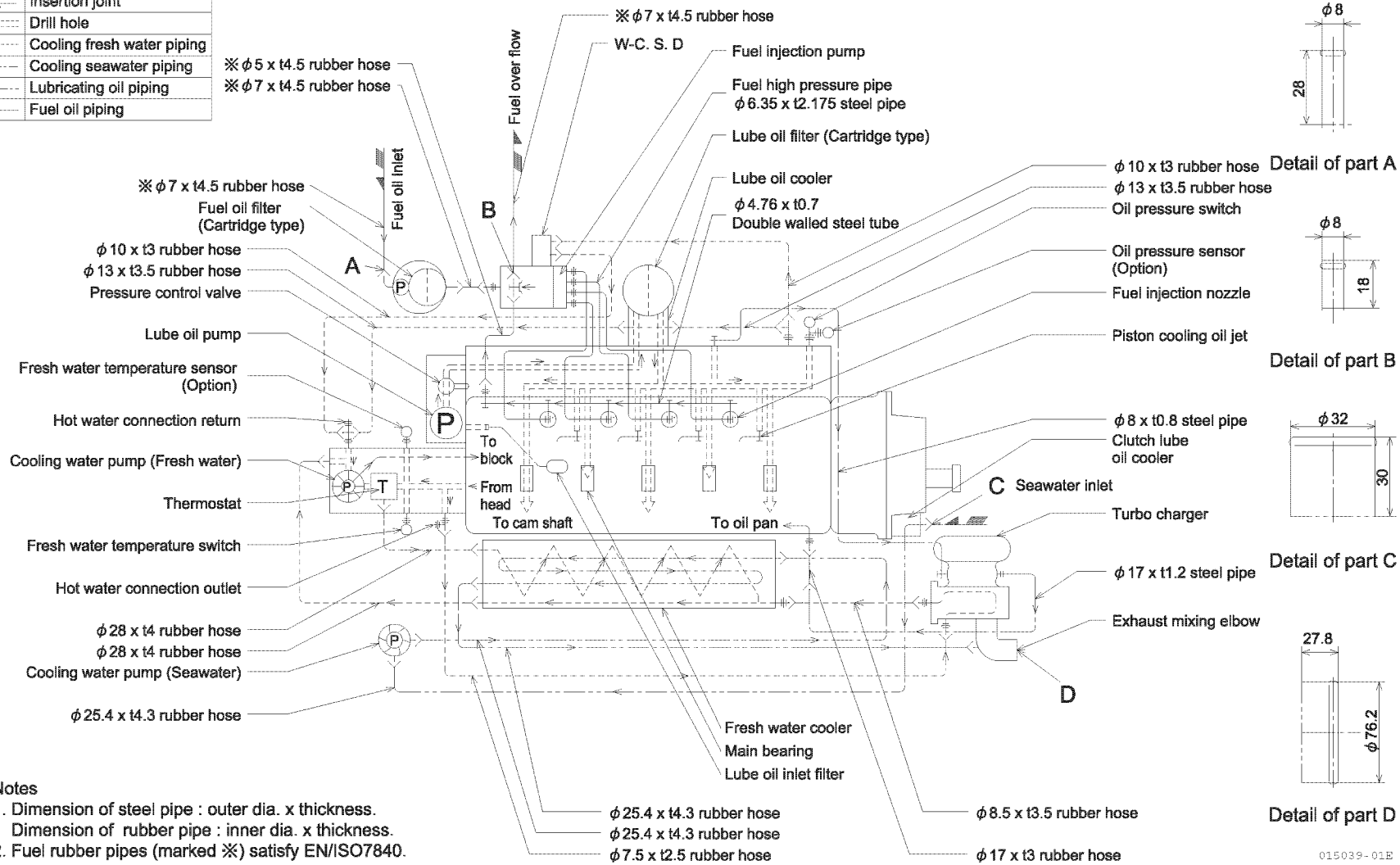

Notes

1. Dimension of steel pipe : outer dia. x thickness.
Dimension of rubber pipe : inner dia. x thickness.
2. Fuel rubber pipes (marked ※) satisfy EN/ISO7840.

015039-01E

Figure 3-30

Marks of piping	
	Screw joint (Union)
	Flange joint
	Eye joint
	Insertion joint
	Drill hole
	Cooling fresh water piping
	Cooling seawater piping
	Lubricating oil piping
	Fuel oil piping

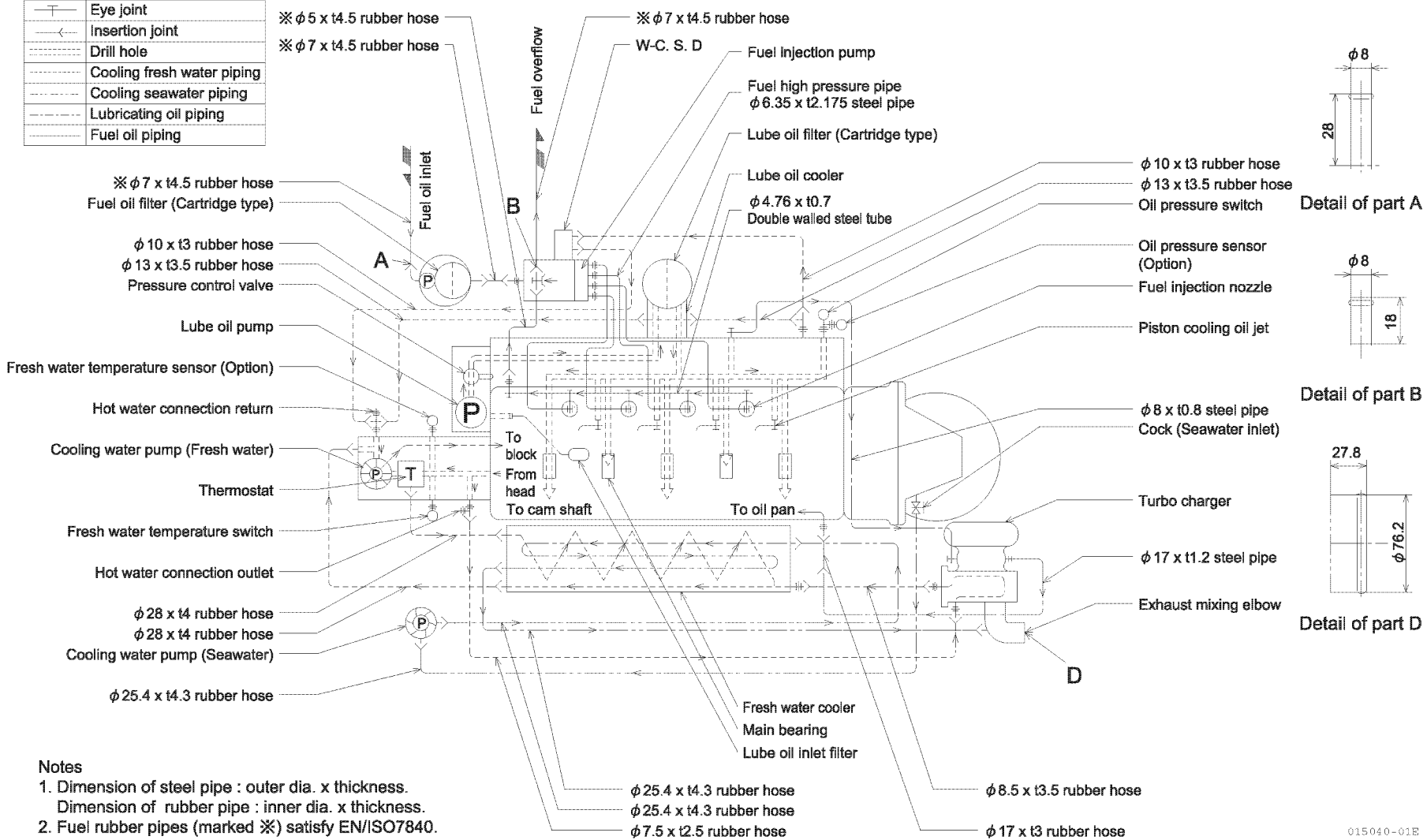

- Notes
1. Dimension of steel pipe : outer dia. x thickness.
Dimension of rubber pipe : inner dia. x thickness.
 2. Fuel rubber pipes (marked ※) satisfy EN/ISO7840.

015040-01B

Figure 3-31

4JH4-HTE Models

4JH4-HTE (KM4A2)

Marks of piping	
	Screw joint (Union)
	Flange joint
	Eye joint
	Insertion joint
	Drill hole
	Cooling fresh water piping
	Cooling seawater piping
	Lubricating oil piping
	Fuel oil piping

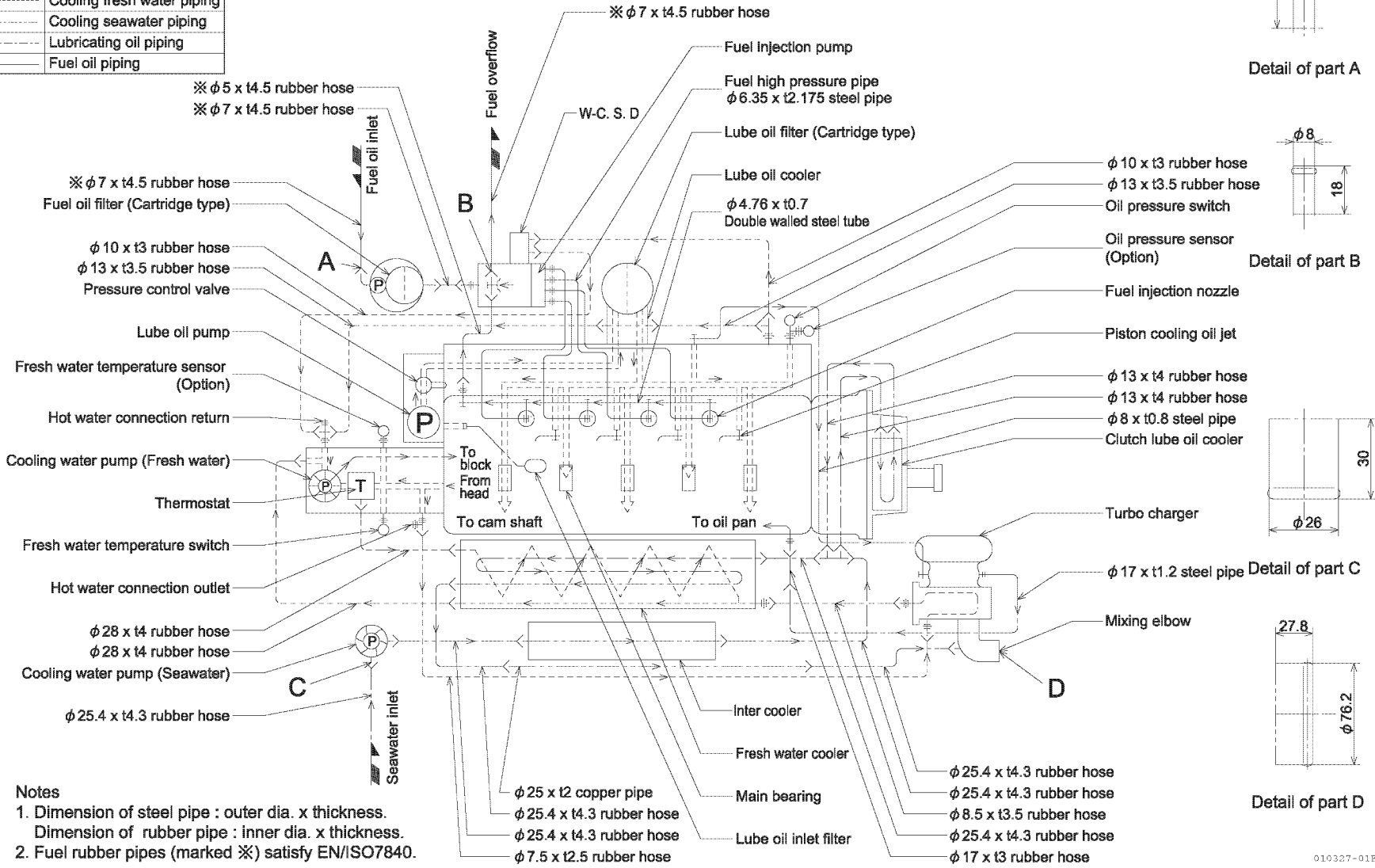

- Notes
1. Dimension of steel pipe : outer dia. x thickness.
Dimension of rubber pipe : inner dia. x thickness.
 2. Fuel rubber pipes (marked ※) satisfy EN/ISO7840.

Figure 3-32

Marks of piping	
	Screw joint (Union)
	Flange joint
	Eye joint
	Insertion joint
	Drill hole
	Cooling fresh water piping
	Cooling seawater piping
	Lubricating oil piping
	Fuel oil piping

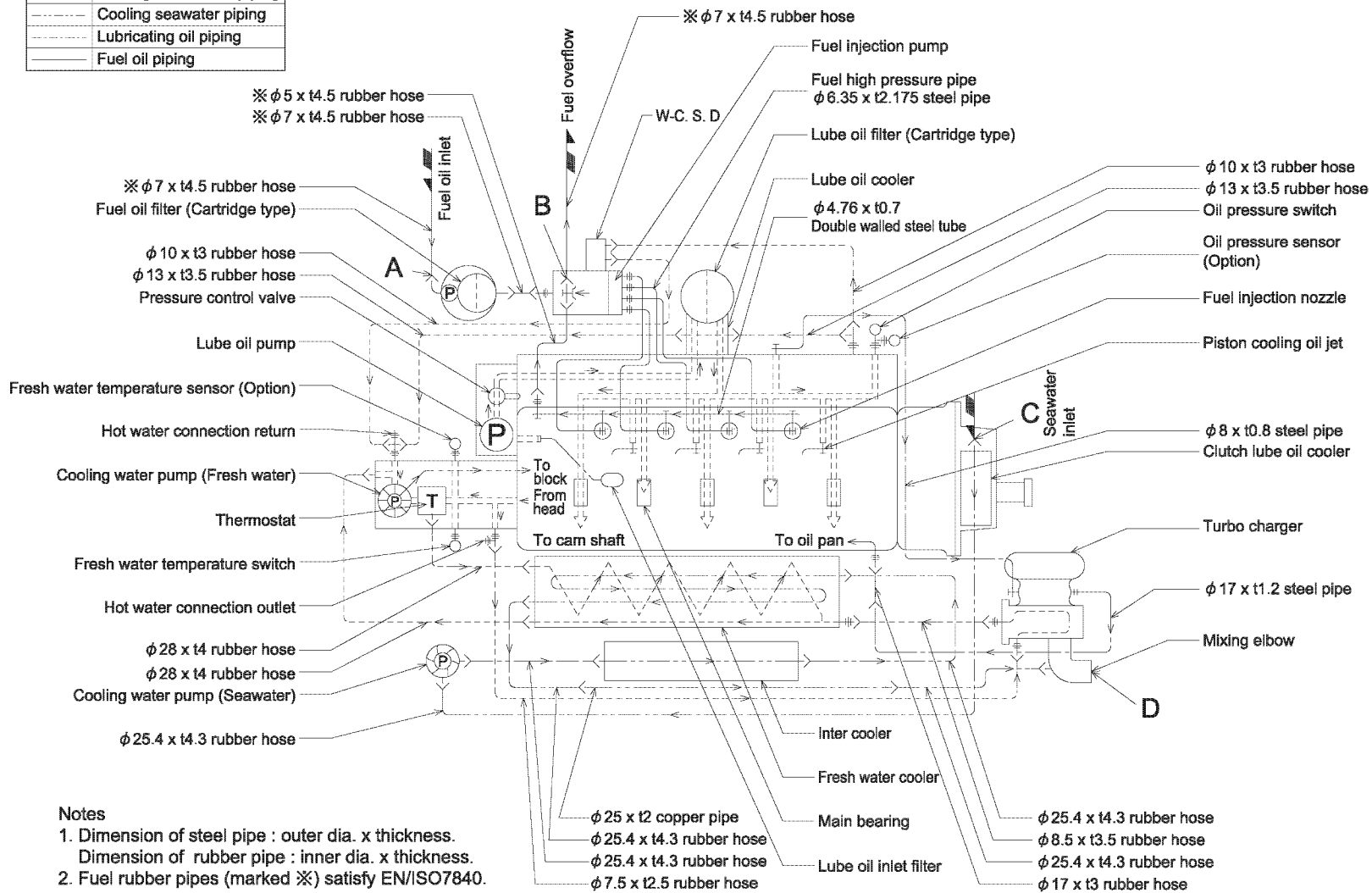

010328-01B

Marks of piping	
	Screw joint (Union)
	Flange joint
	Eye joint
	Insertion joint
	Drill hole
	Cooling fresh water piping
	Cooling seawater piping
	Lubricating oil piping
	Fuel oil piping

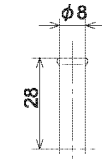
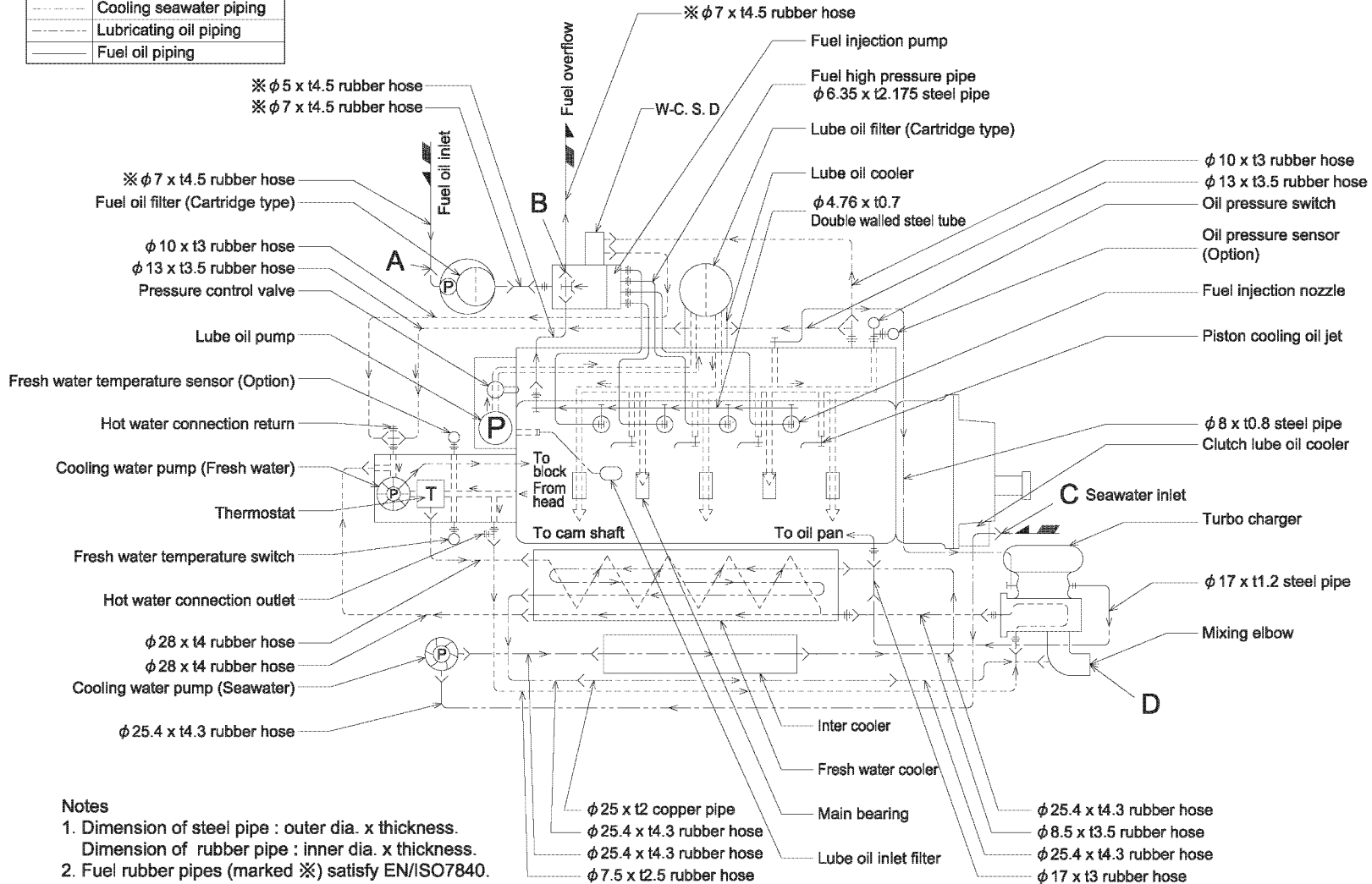

Detail of part A

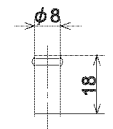

Detail of part B

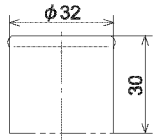

Detail of part C



Detail of part D

010329-01B

Notes

- Dimension of steel pipe : outer dia. x thickness.
Dimension of rubber pipe : inner dia. x thickness.
- Fuel rubber pipes (marked ※) satisfy EN/ISO7840.

Figure 3-34

LOCATION OF NAMEPLATES

The following figures show the location of informational nameplates on Yanmar JH4 series marine engines.

Engine Nameplates (Typical)

Engine Data and Drive Information Nameplates

The nameplate shown (Figure 3-35) is attached to the engine (OLD). Check the engine's model, output, rpm and serial number on the nameplate.

Model	_____	
Gear Model	_____	
Continuous power kW	_____ / _____	min ⁻¹
Speed of prop shaft	_____	min ⁻¹
Fuel stop power kW	_____ / _____	min ⁻¹
ENG.No.	_____	

YANMAR DIESEL ENGINE

YANMAR CO.,LTD.
 MADE IN JAPAN

Figure 3-35

The nameplate shown (Figure 3-36) is attached to the engine (NEW). Check the engine's model, output, rpm and serial numbers on the nameplate.

Model	_____	
Gear Model	_____	
Continuous power kW	_____ / _____	min ⁻¹
Speed of prop,shaft	_____	min ⁻¹
Fuel stop power kW	_____ / _____	min ⁻¹
ENG.No.	_____	



 **YANMAR**[®] 
YANMAR CO.,LTD.
 MADE IN JAPAN

Figure 3-36

The nameplate shown (Figure 3-37) is attached to the marine gear. Check the marine gear's model, gear ration, oil used, oil quantity and serial number.

MODEL	KM
GEAR RATIO	
OIL	SAE ^{20/30} HD
OIL QTY.	LTR.
NO.	

KANZAKI
OSAKA JAPAN

Figure 3-37

The nameplate shown (Figure 3-38) is attached to the sail drive (only for 4JH4-TE). Check the sail drive model and serial number.

MODEL	_____
PASSED MARK	_____
MFG.NO.	_____

YANMAR SAIL DRIVE

YANMAR CO.,LTD.
 MADE IN JAPAN

Figure 3-38

DIESEL FUEL

Diesel Fuel Specifications

Diesel fuel should comply with the following specifications. The table lists several specifications for diesel fuels.

DIESEL FUEL SPECIFICATION	LOCATION
No. 2-D, No. 1-D, ASTM D975-94	USA
EN590:96	European Union

Additional Technical Fuel Requirements

- The fuel cetane number should be 48 or higher.
- The sulfur content must not exceed 0.3% by volume. Less than 0.05% is preferred.
- Water and sediment in the fuel should not exceed 0.05% by volume.
- Ash content not to exceed 0.01% by mass.
- Carbon residue content not to exceed 0.35% by volume. Less than 0.1% is preferred.
- Total aromatics content should not exceed 35% by volume. Less than 30% is preferred.
- PAH (polycyclic aromatic hydrocarbons) content should be below 10% by volume.
- NEVER mix kerosene, used engine oil, or residual fuels with the diesel fuel.
- NEVER use Biocide or mix winter and summer fuels.
- Keep the fuel tank and fuel-handling equipment clean at all times.
- Poor quality fuel can reduce engine performance and / or cause engine damage.
- Fuel additives are not recommended. Some fuel additives may cause poor engine performance.

Diesel Fuel Lines

NOTICE: The fuel supply line between the fuel tank and engine must have minimum diameter of 8 mm (0.315 in.).

Shown is a typical installation of a boat fuel system. Fuel supply (**Figure 3-39, (2)**) and return (**Figure 3-39, (4)**) lines connect to fittings at the engine.

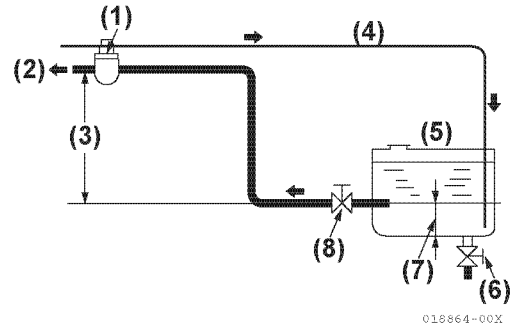

Figure 3-39

- 1 – To Fuel Feed Pump
- 2 – To fuel injection pump
- 3 – Less than 500 mm (19.68 in.)
- 4 – Fuel Return Line
- 5 – Fuel Tank
- 6 – Fuel Tank Drain Cock
- 7 – 20 to 30 mm (0.75 to 1.125 in.)
- 8 – Fuel Shut-off Valve

Install a drain cock (**Figure 3-39, (6)**) at the bottom of the fuel tank to remove water and contaminants.

Boat fuel return system restriction must not exceed 200 mmAq (7.87 in.Aq).

Note: Yanmar does not recommend installing additional fuel filtration before the engine. The engine is equipped with a fuel / water separation filter, plus a fine filter.

Diesel fuel lines for 4JH4AE only

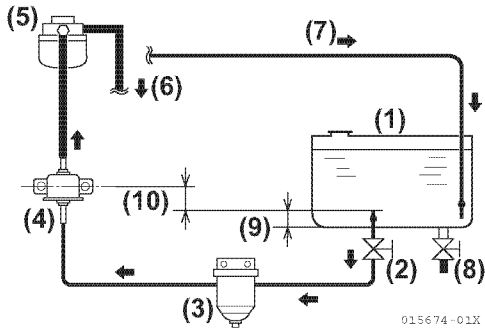

Figure 3-40

- 1 – Fuel Tank
- 2 – Fuel Cock
- 3 – Water Separator
- 4 – Fuel Feed Pump
- 5 – Fuel Filter
- 6 – To Fuel Injection Pump
- 7 – Fuel Return Line
- 8 – Drain Cock
- 9 – 20 - 30 mm (0.75 - 1.25 in.) approximate
- 10 – Less than 400 mm (16.38 in.)

Bleeding the Fuel System

The fuel system needs to be bled under certain conditions.

- Starting the engine for the first time.
- After running out of fuel and fuel has been added to the fuel tank.
- After fuel system maintenance such as changing fuel filters, draining the fuel filter / water separator, or replacing a fuel system component. **NOTICE: NEVER crank the engine using the starter motor to prime the fuel system. This may cause the starter motor to overheat and damage the starter.**

3JH4E Engine

1. Check the fuel level in the fuel tank. Replenish if insufficient.
2. Open the fuel cock of the fuel tank.
3. Loosen the air bleeding bolt (**Figure 3-41, (2)** of the fuel filter by turning it 2 or 3 turns.

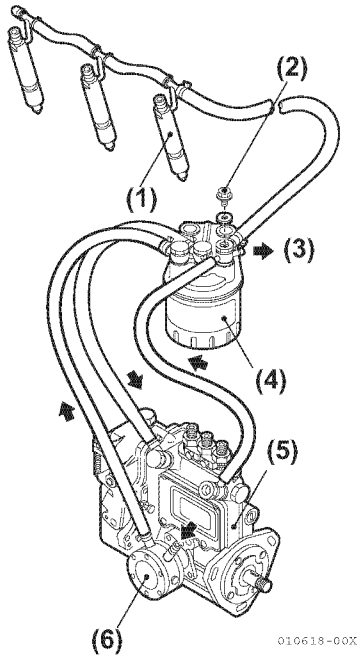

Figure 3-41

- 1 – Fuel Injector
- 2 – Air Bleeding Bolt
- 3 – To Fuel Tank
- 4 – Fuel Filter
- 5 – Fuel Injection Pump
- 6 – Fuel Feed Pump

4. Feed fuel with the fuel feed pump by moving the lever on the feed pump up and down.
5. Allow the fuel containing air bubbles to flow out from the air bleeding bolt hole. When the fuel no longer contains bubbles, tighten the air bleeding bolt. This completes the air bleeding of the fuel system.
6. After the engine start-up, the automatic air-bleeding device works to purge the air in the fuel system.

4JH4AE Engine

1. Check the fuel level in the fuel tank. Replenish if insufficient.
2. Open the fuel cock of the fuel tank.
3. Loosen the air bleeding bolt (**Figure 3-42, (4)**) of the fuel filter by turning it 2 or 3 turns.

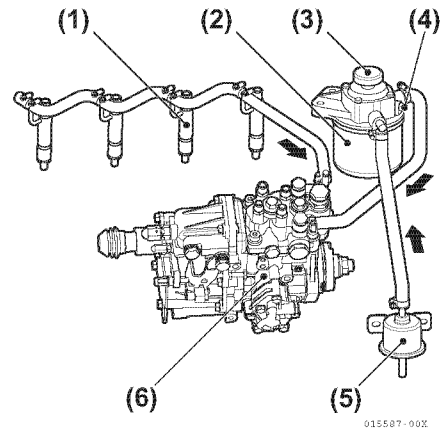

Figure 3-42

- 1 – Fuel Injector
- 2 – Fuel Filter
- 3 – Priming Pump
- 4 – Air Bleeding Bolt
- 5 – Fuel Feed Pump
- 6 – Fuel Injection Pump

4. Feed fuel with the fuel feed pump by moving the lever on the feed pump up and down.
5. Allow the fuel containing air bubbles to flow out from the air bleeding bolt hole. When the fuel no longer contains bubbles, tighten the air bleeding bolt. This completes the air bleeding of the fuel system.
6. After the engine start-up, the automatic air-bleeding device works to purge the air in the fuel system.

4JH4-HTE Engine

1. Check the fuel level in the fuel tank. Replenish if insufficient.
2. Open the fuel cock of the fuel tank.
3. Loosen the air bleeding bolt (**Figure 3-43, (2)**) of the fuel filter by turning it 2 or 3 turns.

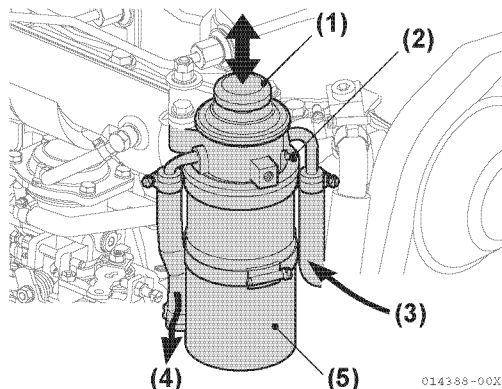

Figure 3-43

- 1 – Priming Pump
- 2 – Air Bleeding Bolt
- 3 – From Fuel Tank
- 4 – To Fuel Injection Pump
- 5 – Fuel Filter

4. Feed fuel with the fuel feed pump by moving the lever on the feed pump (**Figure 3-43, (1)**) up and down.
5. Allow the fuel containing air bubbles to flow out from the air bleeding bolt hole. When the fuel no longer contains bubbles, tighten the air bleeding bolt. This completes the air bleeding of the fuel system.
6. After the engine start-up, the automatic air-bleeding device works to purge the air in the fuel system.

ENGINE OIL

Engine Oil Specifications

Use an engine oil that meets or exceeds the following guidelines and classifications:

Service Categories

- SAE Viscosity: 10W30 or 15W40
The 10W30 and 15W40 can be used throughout the year. See **Figure 3-44**.

Selection of viscosity (SAE Service grade)

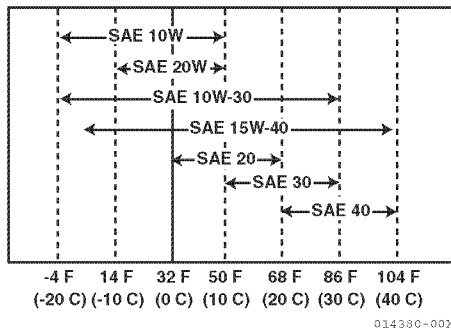

Figure 3-44

- API Classification:

3JH4E 4JH4-TE 4JH4-HTE	CD or higher
4JH4AE	CH-4 or higher

Definitions

- SAE (Society of Automotive Engineer, API (American Petroleum Institute)

Note:

1. Be sure the engine oil, engine oil storage containers, and engine oil filling equipment are free of sediment and water.
2. Change the engine oil after the first 50 hours of operation and then at every 250 hours (or annually) thereafter.
3. Select the oil viscosity based on the ambient temperature where the engine is operated. See **Figure 3-44**
4. Yanmar does not recommend the use of engine oil additives.

Note: Yanmar recommends using genuine Yanmar marine oil, specifically formulated for the JH4 engine. Contact your authorized Yanmar Marine dealer or distributor.

ENGINE COOLANT

Engine Coolant Specifications

Note: In the U.S., LLC is required for the warranty to be valid.

Engine Coolant Mixture

NOTICE: ALWAYS add LLC to deionized soft water, especially when operating in cold weather. Without LLC, cooling performance will decrease due to scale and rust in the cooling system. Water alone may freeze and form ice; it expands approximately 9% in volume.

Use the proper amount of coolant concentrate for the ambient temperature as specified by the LLC manufacturer. LLC concentration should be a minimum of 30% to a maximum of 60%. Too much LLC will decrease the cooling efficiency.

NEVER mix different types or brands of LLC or a harmful sludge may form.

NEVER use hard water. Use deionized water.

Follow the manufacturer's recommendations. Use the proper LLC which will not have any adverse effects on the materials (cast iron, aluminum, copper, etc.) of the engine's freshwater cooling system.

Recommended Engine Coolant

- Texaco Long Life Coolant, both standard and premixed. Product code 7997 and 7998.
- Havoline Extended Life Antifreeze / Coolant. Product code 7994.

Remove scale from the cooling system periodically by flushing the system.

Note: Yanmar recommended using genuine Yanmar antifreeze / coolant. Contact your authorized Yanmar dealer or distributor.

PRINCIPAL ENGINE SPECIFICATIONS

3JH4E Engine Specifications

Specification		3JH4E			
		KM35P	KM35A	SD40 / SD50	Bobtail
Marine Gear Model					
Use		Pleasure use			
Type		Vertical water cooled 4-cycle diesel engine			
Combustion system		Direct injection			
Aspiration		Natural aspiration			
Number of cylinders		In-line 3			
Bore x stroke		88 mm x 90 mm (3.46in. x 3.54in.)			
Displacement		1.642 L (100.20 cu in.)			
Continuous power	Output at crankshaft / Engine speed	26.7 kW (36.3 hp metric)/2907 minimum ⁻¹			
Maximum Rated Output Power	Output at crankshaft / Engine speed	29.4 kW (40.0 hp metric) / 3000 minimum ⁻¹ * 28.7 kW (39.0 hp metric) / 3000 minimum ⁻¹ **			
	Output at propeller / Engine speed	28.0 kW (38.1 hp metric) / 3000 minimum ⁻¹ * 27.4 kW (37.3 hp metric) / 3000 minimum ⁻¹ **	-	-	-
Installation		Flexible mounting			
Fuel injection timing		FID 12 ± 1 deg b.T.D.C (FIC 13 ± 1 deg b.T.D.C)			
Fuel injection opening pressure		21.6 ± 0.5 MPa			
Main power take off		At flywheel end			
Direction of Rotation	Crankshaft	Counterclockwise viewed from stern			
	Propeller shaft (Ahead)	Clockwise viewed from stern	-	-	-
Cooling system		Freshwater cooling with heat exchanger			

Note: Density of fuel: 0.842g/cm³ at 15°C
1 hp metric=0.7355 kW

* Rating Condition: Temperature of fuel; 25°C at FO pump inlet; ISO 3046-1

** Rating Condition: Temperature of fuel; 40°C at FO pump inlet; ISO 8665

Specification		3JH4E			
		KM35P	KM35A	SD40 / SD50	Bobtail
Marine Gear Model					
Lubricating system		Complete enclosed forced lubrication system			
Coolant capacity (fresh)		Engine 4.5 L (4.8 qt), Coolant recovery tank: 0.8 L (0.8qt)			
Lubricating oil capacity (engine)	Rake angle	at rake angle 8°	at rake angle 0°		-
	Total ***	5.0 ± 0.3 L (5.3 ± 0.3 qt)	5.5 ± 0.3 L (5.8 ± 0.3 qt)		
	Oil pan only	4.5 ± 0.3 L (4.8 ± 0.3 qt)	5.0 ± 0.3 L (5.3 ± 0.3 qt)		
	Effective ****	1.1 L (1.2 qt)	1.2 L (1.3 qt)		
Starting system	Type	Electric			
	Starting motor	DC 12V - 1.4 kW			
	AC generator	12V - 80A (12V - 60A optional)			
Engine dimension	Overall length	777 mm (30.6 in.)	776 mm (30.6 in.)	700 mm (27.6 in.)	
	Overall width	539 mm (21.2 in.)			
	Overall height	623 mm (24.5 in.)			
Flywheel major dimension		D300 x 66 mm (11.8 x 2.6 in.)			
Engine dry mass (include marine gear)		185 kg (408 lb)	186 kg (410 lb)	213 kg engine: 173 kg (470 lb) (engine: 381 kg)	173 kg (467 lb)

Note: Density of fuel: 0.842g/cm³ at 15°C
 1 hp metric=0.7355 kW

*** The total oil quantity includes oil in oil pan, channels, coolers and filter.

****The effective amount of oil shows the difference in maximum scale of the dipstick and minimum scale.

4JH4AE Engine Specifications

Engine Model		4JH4AE			
Marine Gear Model		KM35P	ZF30M	KM35A2	KM4A1
Use		Pleasure use			
Type		Vertical water cooled 4-cycle diesel engine			
Combustion system		Direct injection			
Air charging		Natural aspiration			
Number of cylinders		4			
Bore x stroke		88 mm x 90 mm (3.46 in. x 3.54 in.)			
Displacement		2.190 L (133.64 cu in.)			
Continuous power	Output at crankshaft / Engine speed	36.0 kW (48.9 hp metric) / 2907 minimum ⁻¹			
Maximum Rated Output Power	Output at crankshaft / Engine speed	39.6 kW (53.8 hp metric) / 3000 minimum ⁻¹ *			
	Output at propeller / Engine speed	38.0 kW (51.7 hp metric) / 3000 minimum ⁻¹	-	-	-
Installation		Flexible mounting			
Fuel injection timing		FIR 5 ± 1° BTDC (at Maximum Rated Output Power) (FIT 18 ± 1° BTDC (at Plunger Lift 2.5)			
Fuel injection opening pressure		19.6 - 20.6 MPa			
Main power take off		At flywheel end			
Direction of Rotation	Crankshaft	Counterclockwise viewed from stern			
	Propeller shaft (Ahead)	Clockwise viewed from stern			
Cooling system		Freshwater cooling with heat exchanger			
Lubricating system		Complete enclosed forced lubrication system			
Coolant capacity (fresh)		Engine 6.0 L (6.3 qt), Coolant recovery tank: 0.8 L (0.8 qt)			
Lubricating oil capacity (engine)	Rake angle	at rake angle 8°		at rake angle 0°	
	Total **	5.0 ± 0.3 L (5.3 ± 0.3 qt)		5.5 ± 0.3 L (5.8 ± 0.3 qt)	
	Oil pan only	4.5 ± 0.3 L (4.8 ± 0.3 qt)		5.0 ± 0.3 L (5.3 ± 0.3 qt)	
	Effective ***	1.2 L (1.3 qt)		1.4 L (1.5 qt)	
Starting system	Type	Electric			
	Starting motor	DC 12 V - 1.4 kW			
	AC generator	12 V - 80 A			

Note: Density of fuel: 0.842g/cm³ at 15°C.
1 hp metric = 0.7355 kW

* Rating Condition: Temperature of fuel; 40°C at FO pump inlet; ISO 8665

** The "total" oil quantity includes oil in oil pan, channels, coolers and filter.

*** The effective amount of oil shows the difference in maximum scale of the dipstick and minimum scale.

4JH4AE Specifications (Continued)

Engine Model		4JH4AE			
Marine Gear Model		KM35P	ZF30M	KM35A2	KM4A
Engine dimension	Overall length	871 mm (34.3 in.)	950 mm (37.4 in.)	864 mm (34.0 in.)	922 mm (36.3 in.)
	Overall width	560 mm (22.0 in.)			
	Overall height	625 mm (24.6 in.)			
Flywheel major dimension		D300 x 66 mm (11.8 x 2.6 in.)			
Engine dry mass (include marine gear)		213 kg (470 lb)	229 kg (505 lb)	214 kg (472 lb)	230 kg (507 lb)

4JH4AE Specifications (Continued)

Engine Model		4JH4AE	
Sail Drive Model		SD50	Bobtail
Use		Pleasure use	
Type		Vertical water cooled 4-cycle diesel engine	
Combustion system		Direct injection	
Air charging		Natural aspiration	
Number of cylinders		4	
Bore x stroke		88 x 90 mm (3.46 x 3.54 in.)	
Displacement		2.190 L	
Continuous power	Output at crankshaft / Engine speed	36.0 kW (48.9 hp metric)/2907 minimum ⁻¹	
Maximum Rated Output Power	Output at crankshaft / Engine speed	39.6 kW (53.8 hp)/3000 minimum ⁻¹ *	
	Output at propeller / Engine speed	-	
Installation		Flexible mounting	
Fuel injection timing		FIR 5 ± 1° BTDC (at Maximum Rated Output Power) (FIT 18 ± 1° BTDC (at Plunger Lift 2.5)	
Fuel injection opening pressure		19.6 - 20.6 MPa	
Main power take off		At flywheel end	
Direction of Rotation	Crankshaft	Counterclockwise viewed from stern	
	Propeller shaft(Ahead)	Clockwise viewed from stern	
Cooling system		Freshwater cooling with heat exchanger	
Lubricating system		Closed forced lubrication system	
Coolant capacity (fresh)		Engine 6.0 L (6.3 qt), Coolant recovery tank: 0.8 L (0.8 qt)	
Lubricating oil capacity (engine)	Rake angle	at rake angle 0°	
	Total **	5.5 ± 0.3 L (5.8 ± 0.3 qt)	
	Oil pan only	5.0 ± 0.3 L (5.3 ± 0.3 qt)	
	Effective ***	1.4 L (1.5 qt)	
Starting system	Type	Electric	
	Starting motor	DC 12 V - 1.4 kW	
	AC generator	12 V - 80 A	

Note: Density of fuel: 0.842g/cm³ at 15°C.
1 hp metric = 0.7355 kW

* Rating Condition: Temperature of fuel; 40°C at fuel pump inlet; ISO 8665

** The "total" oil quantity includes oil in oil pan, channels, coolers and filter.

*** The effective amount of oil shows the difference in maximum scale of the dipstick and minimum scale.

Engine Model		4JH4AE	
Sail Drive Model		SD40 / SD50	Bobtail
Engine dimension	Overall length	795 mm (31.3 in.)	
	Overall width	560 mm (22.0 in.)	
	Overall height	625 mm (24.6 in.)	
Flywheel major dimension		D300 x 66 mm (11.8 x 2.6 in.)	
Engine dry mass (include marine gear)		241 kg engine: 201 kg (531 lb) (engine: 443 lb)	201 kg (443 lb)

4JH4-TE Engine Specifications

Engine Model		4JH4-TE					
Marine Gear Model		ZF30M	KM4A2	KMH4A	ZF25A	SD50-4T	Bobtail
Use		Pleasure use					
Type		Vertical water cooled 4-cycle diesel engine					
Combustion system		Direct injection					
Air charging		Turbocharged					
Number of cylinders		4					
Bore x stroke		84 x 90 mm (3.31 x 3.54 in.)					
Displacement		1.995 L (121.74 cu in.)					
Continuous power	Output at crankshaft / Engine speed	50.2 kW (68.3 hp metric) / 3101 minimum ⁻¹					
Maximum Rated Output Power	Output at crankshaft / Engine speed	55.2 kW (75.1hp metric) / 3200 minimum ⁻¹ *					
	Output at propeller / Engine speed	53.0 kW (72.1hp metric) / 3200 minimum ⁻¹ *			-		
Installation		Flexible mounting					
Fuel injection timing		Plunger lift at TDC 1.26 ± 0.01 mm (when W-CSD is released)					
Fuel injection opening pressure		21.6 ± 0.5 MPa					
Main power take off		At flywheel end					
Direction of Rotation	Crankshaft	Counterclockwise viewed from stern					
	Propeller shaft (Ahead)	Clockwise from stern	Clockwise or counterclockwise (Bi-rotation)		-		
Cooling system		Freshwater cooling with heat exchanger					
Lubricating system		Complete enclosed forced lubrication system					
Coolant capacity (fresh)		Engine: 7.2 L (7.6 qt), Coolant recovery tank: 0.8 L (0.8 qt)					
Lubricating oil capacity (engine)	Rake angle	7°	0°			7° or 0°	
	Total **	5.7 ± 0.3 L (6.0 ± 0.3 qt)	6.9 ± 0.3 L (7.3 ± 0.3 qt)			Refer to left	
	Oil pan only	5.2 ± 0.3 L (5.5 ± 0.3 qt)	6.4 ± 0.3 L (6.8 ± 0.3 qt)			Refer to left	
	Effective ***	2.4 L (2.5 qt)					
Starting system	Type	Electric					
	Starting motor	DC 12 V - 1.4 kW					
	AC generator	12 V - 80 A (12 V - 60 A optional)					

Note: Density of fuel: 0.842g/cm³ at 15°C.
1 hp metric = 0.7355 kW

* Rating Condition: Temperature of fuel; 40°C at fuel pump inlet; ISO 8665

** The "total" oil quantity includes oil in oil pan, channels, coolers and filter.

*** The effective amount of oil shows the difference in maximum scale of the dipstick and minimum scale.

Engine Model		4JH4-TE					
Marine Gear Model		ZF30M	KM4A2	KMH4A	ZF25A	SD50-4T	Bobtail
Engine dimension	Overall length	923 mm (36.3 in.)	903 mm (35.6 in.)	933 mm (36.7 in.)	1017 mm (40.0 in.)	782 mm (30.8 in.)	782 mm (30.8 in.)
	Overall width	616 mm (24.3 in.)					
	Overall height	659 mm (25.9 in.)					
Flywheel major dimension		D339 x 66 mm (13.3 x 2.6 in.)					
Engine dry mass (include marine gear)		235 kg (518 lb)	237 kg (523 lb)	238 kg (525 lb)	237 kg (523 lb) engine: 173 kg (engine: 381 lb)	249 kg (549 lb) engine: 207 kg (engine: 456 lb)	207 kg (456 lb)

4JH4-HTE Engine Specifications

Engine Model		4JH4-HTE				
Marine Gear Model		ZF30M	KM4A2	KMH4A	ZF25A	Bobtail
Use		Pleasure use				
Type		Vertical water cooled 4-cycle diesel engine				
Combustion system		Direct injection				
Aspiration		Turbocharged				
Number of cylinders		4				
Bore x stroke		84 x 90 mm (3.31 x 3.54 in.)				
Displacement		1.995 L				
Continuous power	Output at crankshaft / Engine speed	73.6 kW (100 hp metric) / 3101 minimum ⁻¹				
Maximum Rated Output Power	Output at crankshaft / Engine speed	80.9 kW (110 hp metric) / 3200 minimum ⁻¹ *				
	Output at propeller / Engine speed	77.7 kW (106 hp metric) / 3200 minimum ⁻¹ *				-
Installation		Flexible mounting				
Fuel injection timing		Plunger lift at TDC 1.26 ± 0.01 mm (when W-CSD is released)				
Fuel injection opening pressure		21.6 ± 0.5 MPa				
Main power take off		At flywheel end				
Direction of Rotation	Crankshaft	Counterclockwise viewed from stern				
	Propeller shaft (Ahead)	Clockwise from stern	Clockwise or counterclockwise (Bi-rotation)			-
Cooling system		Freshwater cooling with heat exchanger				
Lubricating system		Complete enclosed forced lubrication system				
Coolant capacity (fresh)		Engine: 7.2 L (7.6 qt), Coolant recovery tank: 0.8 L (0.8 qt)				
Lubricating oil capacity (engine)	Rake angle	7°	0°			7° or 0°
	Total **	5.7 ± 0.3 L (6.0 ± 0.3 qt)	6.9 ± 0.3 L (7.3 ± 0.3 qt)			Refer to left
	Oil pan only	5.2 ± 0.3 L (5.5 ± 0.3 qt)	6.4 ± 0.3 L (6.8 ± 0.3 qt)			Refer to left
	Effective ***	2.4 L (2.5 qt)				
Starting system	Type	Electric				
	Starting motor	DC 12 V - 1.4 kW				
	AC generator	12 V - 80 A (12 V - 60 A optional)				

Note: Density of fuel: 0.842g/cm³ at 15°C.
1 hp metric = 0.7355 kW

* Rating Condition: Temperature of fuel; 40°C at fuel pump inlet; ISO 8665

** The "total" oil quantity includes oil in oil pan, channels, coolers and filter.

*** The effective amount of oil shows the difference in maximum scale of the dipstick and minimum scale.

Engine Model		4JH4-HTE				
Marine Gear Model		ZF30M	KM4A2	KMH4A	ZF25A	Bobtail
Engine dimension	Overall length	923 mm (36.3 in.)	903 mm (35.6 in.)	933 mm (36.7 in.)	1017 mm (40.0 in.)	782 mm (30.8 in.)
	Overall width	616 mm (24.3 in.)				
	Overall height	659 mm (25.9 in.)				
Flywheel major dimension		D339 x 66 mm (13.3 x 2.6 in.)				
Engine dry mass (include marine gear)		245 kg	247 kg	248 kg	247 kg	217 kg

TIGHTENING TORQUES FOR STANDARD BOLTS AND NUTS

Use the correct amount of torque when tightening fasteners. Applying excessive torque may damage the fastener or component and not enough torque may cause a leak or component failure.

Hexagon Bolts and Nuts

N·m (kgf·m)

Name	Bolt dia. x pitch (mm)	Tightening torque	Remarks
Hexagon bolt with a "7" head and hexagon nut. ("7" mark means JIS strength classification "7T".)	M6 x 1	9.8-11.8 (1.0-1.2)	Apply 80% torque when tightening to aluminum alloy.
	M8 x 1.25	22.5-28.5 (2.3-2.9)	
	M10 x 1.5	44-54 (4.5-5.5)	Apply 60% torque to 4T bolts and locknuts. (4T bolt has no mark on the head.)
	M12 x 1.75	78.2-98.2 (8.0-10.0)	
PT plug (Taper plug)	1/8	9.8 (1.0)	
	1/4	19.6 (2.0)	
	3/8	29.4 (3.0)	
	1/2	58.8 (6.0)	
Line joint bolt	M8	12.7-16.7 (1.3-1.7)	
	M10	19.5-25.5 (2.0-2.6)	
	M12	24.4-34.4 (2.5-3.5)	
	M14	39.1-49.1 (4.0-5.0)	
	M16	48.9-58.9 (5.0-6.0)	

Hose Clamps

Note: Reuse and retightening is prohibited for all hose clamps. Always install new hose clamps.

PREPARE ENGINE FOR LONG-TERM STORAGE

NOTICE: Do not drain engine coolant for long-term storage. Antifreeze must be used to avoid freezing and damage to components. Antifreeze will prevent rusting during long-term storage.

1. Change engine oil and filter. *See Change Engine Oil, Replace Engine Oil Filter Element and Clean Engine Oil Cooler on page 8-9.*
2. Drain seawater cooling system. *See Drain and Refill Seawater Cooling System on page 7-10.*
3. Wipe off any dust or oil from the outside of the engine.
4. Drain fuel tank or fill the tank to prevent condensation.
5. Grease the exposed areas and joints of the remote control cables and the bearings of the remote control handle.
6. Seal the intake silencer, exhaust pipe, etc. to prevent moisture or contamination from entering engine.
7. Completely drain bilge in hull bottom.
8. Waterproof the engine room to prevent rain or seawater from entering.
9. Charge the battery once a month to compensate for battery's self-discharge.
10. Remove key from key switch and cover key switch with moisture cap (if equipped).

Abbreviations And Symbols

A	ampere
AC	alternating current
ACEA	Association des Constructeurs Européens d'Automobilies
Ah	ampere-hour
API	American Petroleum Institute
ARB	Air Resources Board
ATDC	after top dead center
BDC	bottom dead center
BTDC	before top dead center
°C	degree Celsius
CARB	California Air Resources Board
CCA	cold cranking amp
cfm	cubic feet per min.
cm	centimeter
cm³	cubic centimeter
cm³/minimum	cubic centimeter per min.
cu in.	cubic inch
D	diameter
DC	direct current
DI	direct injection
DVA	direct volt adapter
EPA	Environmental Protection Agency
ESG	electronic speed governor
°F	degree Fahrenheit
fl oz	fluid ounce (U.S.)
fl oz/minimum	fluid ounce (U.S.) per min.
ft	foot
ft-lb	foot pound*
ft-lbf/minimum	foot pound force per min.
g	gram
gal	gallon (U.S.)
gal/hr	gallon (U.S.) per hour
gal/minimum	gallon (U.S.) per min.
GL	gear lubricant
hp	horsepower (metric)
hr	hour
ID	inside diameter
ID	identification
IDI	indirect injection
in.	inch
in.Aq	inches Aqueous (water)
in.Hg	inches Mercury
in-lb	inch pound**
J	joule
JASO	Japanese Automobile Standards Organization
K	kelvin
kg	kilogram

kgf/cm²	kilogram force per square centimeter
kgf/m	kilogram force per meter
km	kilometers
kPa	kilopascal
kW	kilowatt
L	liter
L/hr	liter per hour
lb	pound
lbf	pound-force
lb-ft	pound foot (Tightening Torque)
lb-in	pound inch (Tightening Torque)
m	meter
mL	milliliter
mm	millimeter
mmAq	millimeter Aqueous (water)
MPa	megapascal
mV	millivolt
N	newton
N·m	newton meter
No.	number
O.D.	outside diameter
oz	ounce
Pa	pascal
PS	horsepower (metric)
psi	pound per square inch
qt	quart (U.S.)
R	radius
rpm	revolutions per min.
SAE	Society of Automotive Engineers
sec.	second
t	short ton 2000 lb
TBN	total base number
TDC	top dead center
V	volt
VAC	volt alternating current
VDC	volt direct current
W	watt

Symbols

°	degree
+	plus
-	minus
±	plus or minus
Ω	ohm
μ	micro
%	percent

* Work torque such as engine torque

** Work torque such as starter motor torque

UNIT CONVERSIONS

Unit Prefixes

Prefix	Symbol	Power
mega	M	x 1,000,000
kilo	k	x 1,000
centi	c	x 0.01
milli	m	x 0.001
micro	μ	x 0.000001

Units of Length

mile	x	1.6090	= km
ft	x	0.3050	= m
in.	x	2.5400	= cm
in.	x	25.4000	= mm
km	x	0.6210	= mile
m	x	3.2810	= ft
cm	x	0.3940	= in.
mm	x	0.0394	= in.

Units of Volume

gal (U.S.)	x	3.78540	= L
qt (U.S.)	x	0.94635	= L
cu in.	x	0.01639	= L
cu in.	x	16.38700	= mL
fl oz (U.S.)	x	0.02957	= L
fl oz (U.S.)	x	29.57000	= mL
cm ³	x	1.00000	= mL
cm ³	x	0.03382	= fl oz (U.S.)

Units of Mass

lb	x	0.45360	= kg
oz	x	28.35000	= g
kg	x	2.20500	= lb
g	x	0.03527	= oz

Units of Force

lbf	x	4.4480	= N
lbf	x	0.4536	= kgf
N	x	0.2248	= lbf
N	x	0.1020	= kgf
kgf	x	2.2050	= lbf
kgf	x	9.8070	= N

Units of Torque

lb-ft	x	1.3558	= N·m
lb-ft	x	0.1383	= kgf/m
lb-in	x	0.1130	= N·m
lb-in	x	0.0115	= kgf/m
kgf/m	x	7.2330	= lb-ft
kgf/m	x	86.8000	= lb-in
kgf/m	x	9.8070	= N·m
N·m	x	0.7376	= lb-ft
N·m	x	8.8510	= lb-in
N·m	x	0.1020	= kgf/m

Units of Pressure

psi	x	0.0689	= bar
psi	x	6.8950	= kPa
psi	x	0.0703	= kg/cm ²
bar	x	14.5030	= psi
bar	x	100.0000	= kPa
bar	x	29.5300	= inHg (60°F)
kPa	x	0.1450	= psi
kPa	x	0.0100	= bar
kPa	x	0.0102	= kg/cm ²
kg/cm ²	x	98.0700	= psi
kg/cm ²	x	0.9807	= bar
kg/cm ²	x	14.2200	= kPa
in.Hg (60°)	x	0.0333	= bar
in.Hg (60°)	x	3.3770	= kPa
in.Hg (60°)	x	0.0344	= kg/cm ²
mmAq	x	0.0394	= in.Aq

Units of Power

hp (metric or PS)	x	0.9863201	= hp SAE
hp (metric or PS)	x	0.7354988	= kW
hp SAE	x	1.0138697	= hp (metric or PS)
hp SAE	x	0.7456999	= kW
kW	x	1.3596216	= hp (metric or PS)
kW	x	1.3410221	= hp SAE

Units of Temperature

°F = (1.8 x °C) + 32
 °C = 0.556 x (°F - 32)

Section 4

PERIODIC MAINTENANCE

Introduction.....	4-3
The Importance of Periodic Maintenance.....	4-3
Performing Periodic Maintenance	4-3
Yanmar Replacement Parts	4-3
Required EPA Maintenance	4-3
EPA Requirements.....	4-3
Conditions to Ensure Compliance with EPA Emission Standards	4-3
Inspection and Maintenance.....	4-3
Periodic Maintenance Schedule.....	4-4
Inspection and Maintenance of EPA Emission-Related Parts... ..	4-6
Inspection and Maintenance of EPA Emission-Related Parts for Non-Road and CI Marine Engines.....	4-6
Periodic Maintenance Procedures	4-7
After Initial 50 Hours of Operation	4-7
Every 50 Hours of Operation	4-7
Every 250 Hours of Operation	4-8
Every 500 Hours of Operation	4-8
Every 1000 Hours of Operation	4-9

This Page Intentionally Left Blank

INTRODUCTION

This section of the *Service Manual* describes the procedures for proper care and maintenance of the engine.

The Importance of Periodic Maintenance

Engine deterioration and wear occurs in proportion to length of time the engine has been in service and the conditions the engine is subject to during operation. Periodic maintenance prevents unexpected downtime, reduces the number of accidents due to poor machine performance and helps extend the life of the engine.

Performing Periodic Maintenance

Perform periodic maintenance procedures in an open, level area free from traffic. If possible, perform the procedures indoors to prevent environmental conditions such as rain, wind or snow from damaging the engine. **DANGER!** **NEVER block windows, vents or other means of ventilation if the engine is operating in an enclosed area. All internal combustion engines create carbon monoxide gas during operation. Accumulation of this gas within an enclosure will cause illness or even death.**

Yanmar Replacement Parts

Yanmar recommends that you use genuine Yanmar parts when replacement parts are needed. Genuine replacement parts help ensure long engine life.

Required EPA Maintenance

To maintain optimum engine performance and compliance with the Environmental Protection Agency (EPA) Regulation Engines, it is essential that you follow the *Periodic Maintenance Schedule on page 4-4* and *Periodic Maintenance Procedures on page 4-7*.

EPA REQUIREMENTS

The EPA emission regulation is applicable only in USA.

Conditions to Ensure Compliance with EPA Emission Standards

This product is an EPA-approved engine.

The following are the conditions that must be met in order to ensure that the emissions during operation meet the EPA standards. Be sure to follow these:

The operating conditions should be as follows:

- Ambient temperature: -16° to +40°C (3° to 104°F)
- Relative humidity: 80% or lower
- 3JH4E / 4JH4AE: Maximum air inlet restriction: 3.9 kPa (400 mm Aq)
- 4JH4-TE / 4JH4-HTE: Maximum air inlet restriction: 2.0 kPa (200 mm Aq)

The fuel and lubricating oil used should be as follows:

- Diesel fuel: ASTM D975 No. 1-D or No. 2-D, or equivalent (minimum cetane No. 45)
- Lubricating oil: Type API, Class CD for Model 3JH4E, 4JH4-TE and 4JH4-HTE engines
Type API, Class CH-4 for Model 4JH4AE engine

Be sure to perform inspections as outlined in *Periodic Maintenance Schedule on page 4-4* and keep a record of the results.

Pay particular attention to these important points:

- Replacing the engine oil
- Replacing the lubricating oil filter
- Replacing the fuel filter
- Replacing the air filter

Note: Inspections are divided into two sections in accordance with who is responsible for performing the inspection: the user or the maker.

Inspection and Maintenance

See *EPA Requirements on page 4-3*.

Inspection and maintenance procedures not shown in this section are covered in *Periodic Maintenance Schedule on page 4-4*.

This maintenance must be performed to keep the emission values of your engine within standard values during the warranty period. The warranty period is determined by the age of the engine or the number of hours of operation.

PERIODIC MAINTENANCE SCHEDULE

Daily and periodic maintenance is important to keep the engine in good operating condition. The following is a summary of maintenance items by periodic maintenance intervals. Periodic maintenance intervals vary depending on engine application, loads, diesel fuel and engine oil used and are hard to establish definitively. The following should be treated only as a general guideline.

○: Check ◇: Replace ●: Contact your authorized Yanmar Marine dealer or distributor

System	Item	Periodic Maintenance Interval				
		Every 50 hours or monthly whichever comes first	Every 250 hours or one year whichever comes first	Every 500 hours or 2 years whichever comes first	Every 1000 hours or 4 years whichever comes first	
Whole	Visual inspection of engine exterior					
Fuel System	Check the fuel level and refill if necessary					
	Drain water and sediment from fuel tank	○ Initial 50	○			
	Drain the fuel / water separator	○				
	Replace the fuel filter element		◇			
	Check the fuel injection timing				●	
	Check the fuel injector spray pattern*				●*	
Lubricating System	Check the lubricating oil level	Engine				
		Marine Gear				
	Replace the lubricating oil	Engine	◇ Initial 50	◇		
		Marine Gear	◇ Initial 50	◇		
	Replace the oil filter element	Engine	◇ Initial 50	◇		
		Marine Gear (if equipped)	◇ Initial 50	◇		
Cooling System	Seawater outlet					
	Check coolant level					
	Check or replace the seawater pump impeller		○		◇	
	Replace coolant	Every year When long life coolant is used, replace every two years. See <i>Engine Coolant Specifications on page 3-44.</i>				
	Clean and check the seawater passages				●	

○: Check ◇: Replace ●: Contact your authorized Yanmar Marine dealer or distributor

System	Item	Periodic Maintenance Interval			
		Every 50 hours or monthly whichever comes first	Every 250 hours or one year whichever comes first	Every 500 hours or 2 years whichever comes first	Every 1000 hours or 4 years whichever comes first
Air Intake / Exhaust System	Clean intake silencer (air cleaner) element		○		
	Clean the exhaust / water mixing elbow		○	◇	
	Clean the turbocharger* 4JH4-TE / 4JH4-HTE only		●*		
	Check diaphragm assembly 3JH4E / 4JH4AE only				●
Electrical System	Check alarm and indicators				
	Check the electrolyte level in the battery	○			
	Check tension of / replace alternator V-belt	○ Initial 50	○		◇
	Check the wiring connectors		○		
Engine Cylinder Head and Block	Check for leakage of fuel, engine oil and engine coolant				
	Tighten all major nuts and bolts		●		
	Adjust intake / exhaust valve clearance	● Initial 50			●
Miscellaneous Items	Check the remote control cable operation	○ Initial 50			●
	Adjust the propeller shaft alignment	● Initial 50			●
	Replace rubberized hoses (fuel and water)	Replace every 2 years or every 2000 hours, whichever comes first.			

* For EPA requirements see *Inspection and Maintenance of EPA Emission-Related Parts* on page 4-6.

Note: These procedures are considered normal maintenance and are performed at the owner's expense.

Inspection and Maintenance of EPA Emission-Related Parts

- Marine diesel engines less than 37 kW: 3JH4E is certified as EPA non-road engine
- Marine diesel engines greater than 37 kW: 4JH4AE, 4JH4-TE and 4JH4-HTE are certified as EPA CI marine engines

Inspection and Maintenance of EPA Emission-Related Parts for Non-Road and CI Marine Engines

Parts	Interval
Clean fuel injection nozzle	1500 hours
Check fuel injection nozzle pressure and spray pattern	3000 hours
Check fuel injection pump adjustment	
Check turbocharger adjustment (if equipped)	
Check electronic engine control unit and its associated sensors and actuators (if equipped)	

Note: The inspection and maintenance items shown above to be performed at your Yanmar dealer or distributor.

PERIODIC MAINTENANCE PROCEDURES

After Initial 50 Hours of Operation

Perform the following maintenance after the initial 50 hours of operation.

- **Draining Water and Sediment from the Fuel Tank**
See Cleaning Fuel Injection Nozzle Cavities on page 6-15
- **Changing the Engine Oil and Replace the Engine Oil Filter**
See Change Engine Oil, Replace Engine Oil Filter Element and Clean Engine Oil Cooler on page 8-9
- **Adjusting / Replacing the Alternator V-belt**
See Replace V-Belt on page 11-9
- **Adjusting Intake / Exhaust Valve Clearance**
See Inspection of Intake / Exhaust Valves and Valve Guides on page 5-55
- **Checking Remote Control Cable Operation**
See Check and Adjust the Remote Control Operation on page 5-114
- **Adjusting Propeller Shaft Alignment (If Equipped with Marine Gear)**
See Principal Engine Specifications on page 3-45

Every 50 Hours of Operation

After you complete the initial 50 hour maintenance procedures, perform the following procedures every 50 hours or monthly thereafter, whichever comes first.

- **Draining the Fuel Filter / Water Separator**
See Fuel / Water Separator Replacement on page 6-38
- **Checking Battery Electrolyte Level (Serviceable Batteries Only)**
See Tests and Adjustments on page 5-28

Every 250 Hours of Operation

Perform the following maintenance every 250 hours of operation or one year, whichever comes first.

- **Draining Water and Sediment from the Fuel Tank**
See Cleaning Fuel Injection Nozzle Cavities on page 6-15
- **Replacing the Fuel Filter Element**
Fuel System Service on page 6-14
- **Changing Engine Oil and Replacing the Engine Oil Filter Element**
See Change Engine Oil, Replace Engine Oil Filter Element and Clean Engine Oil Cooler on page 8-9
- **Checking or Replacing the Seawater Pump Impeller**
See Seawater Pump on page 7-23
- **Cleaning the Intake Silencer (Air Cleaner) Element**
See Clean Air Cleaner on page 9-6
- **Replacing Coolant (LLC)**
See Remove and Install Coolant Pump on page 7-20
- **Replacing the Zinc Anodes (4JH4-TE and 4JH4-HTE only)**
See Drain and Fill Closed Cooling System on page 7-13
- **Cleaning the Exhaust / Water Mixing Elbow**
- **Cleaning the Turbocharger (4JH4-TE and 4JH4-HTE only)**
See Turbocharger Service on page 9-6
- **Adjusting / Replacing the Alternator V-belt**
See Replace V-Belt on page 11-9
- **Tightening All Major Nuts and Bolts**
See Main Bolt and Nut on page 14-15

Every 500 Hours of Operation

Perform the following maintenance every 500 hours of operation or 2 years, whichever comes first.

- **Cleaning the Engine Oil Cooler**
See Change Engine Oil, Replace Engine Oil Filter Element and Clean Engine Oil Cooler on page 8-9
- **Replacing Coolant (LLC)**
See Remove and Install Coolant Pump on page 7-20
- **Replacing the Zinc Anodes (4JH4-TE and 4JH4-HTE only)**
See Drain and Fill Closed Cooling System on page 7-13
- **Replacing Rubberized Hoses (Fuel and Water)**
See Fuel System Service on page 6-14 and Cylinder Block Inspection on page 5-48

Every 1000 Hours of Operation

Perform the following maintenance every 1000 hours of operation or 4 years, whichever comes first.

- **Checking the Fuel Injection Timing**
See Flywheel and Housing on page 5-81
- **Checking the Fuel Injector Spray Pattern**
See Fuel Injectors on page 6-63
- **Checking or Replacing the Seawater Pump Impeller**
See Seawater Pump on page 7-23
- **Replacing Coolant (LLC)**
See Remove and Install Coolant Pump on page 7-20
- **Cleaning the Seawater Passages**
See Drain and Fill Closed Cooling System on page 7-13
- **Replacing the Zinc Anodes (4JH4-TE and 4JH4-HTE only)**
See Drain and Fill Closed Cooling System on page 7-13
- **Checking the Diaphragm Assembly (4JH4-TE and 4JH4-HTE only)**
See 4JH4-TE and 4JH4-HTE Engines on page 5-38
- **Replacing the Alternator V-belt**
See Replace V-Belt on page 11-9
- **Adjusting Intake / Exhaust Valve Clearance**
See Inspection of Intake / Exhaust Valves and Valve Guides on page 5-55
- **Checking Remote Control Cable Operation**
See Check and Adjust the Remote Control Operation on page 5-114
- **Adjusting Propeller Shaft Alignment (If Equipped with Marine Gear)**
See Principal Engine Specifications on page 3-45
- **Replacing Rubberized Hoses (Fuel and Water)**
See Fuel System Service on page 6-14 and Cylinder Block Inspection on page 5-48

This Page Intentionally Left Blank

Section 5

ENGINE

	Page
Safety Precautions	5-3
Introduction.....	5-3
Specifications	5-4
General Information.....	5-4
Test and Adjustment Specifications	5-4
Repair Specifications.....	5-5
Special Torque Chart	5-12
Standard Torque Chart (without Lubricating Oil).....	5-13
Special Service Tools.....	5-14
Measuring Instruments.....	5-21
Sealants and Compounds.....	5-26
Tests and Adjustments.....	5-28
Test Compression	5-28
Disassembly	5-29
Inspection	5-48
Cylinder Block.....	5-48
Cylinder Head.....	5-50
Piston and Piston Rings	5-62
Connecting Rod.....	5-68
Crankshaft and Main Bearings	5-72
Camshaft and Tappets	5-76
Timing Gear.....	5-80
Flywheel and Housing	5-81
Assembly.....	5-84
Check and Adjust the Remote Control Operation	5-114

This Page Intentionally Left Blank

SAFETY PRECAUTIONS

Before you service the engine, read the following safety information and review the *Safety Section on page 2-1*.

WARNING

The safety message that follows has a **WARNING** level hazard. The safety message describes a hazardous situation, which, if not avoided, *could* result in death or serious injury.



ALWAYS ensure that all connections are tightened to specifications after repair is made to the exhaust system. All internal combustion engines create carbon monoxide gas during operation and special precautions are required to avoid carbon monoxide poisoning.

NOTICE

Indicates a situation which can cause damage to the machine, personal property and / or the environment or cause the equipment to operate improperly.

NEVER attempt to adjust the low or high idle speed limit screw. This may impair the safety and performance of the engine and shorten its life. If adjustment is ever required, see your authorized Yanmar Marine dealer or distributor.

INTRODUCTION

This section of the *Service Manual* describes the disassembly, inspection, and reassembly of the 3JH4 and 4JH4 Series engines.

SPECIFICATIONS

General Information

Engine Model	3JH4E	4JH4AE	4JH4 - TE	4JH4 - HTE
Number of Cylinders	In-Line 3	In-Line 4		
Bore	88 mm (3.465 in.)		84 mm (3.307 in.)	
Stroke	90 mm			
Effective Displacement	1642 cc (100.20 cu in.)	2190 cc (133.64 cu in.)	1995 cc (121.74 cu in.)	
Compression Ratio	19.0:1			
Compression Pressure (at 250 minimum ⁻¹)	3.4 ± 0.1 MPa (493 ± 14.5 psi)			3.2 ± 0.1 MPa (464 ± 14.5 psi)
Valve Clearance -Intake / exhaust	0.2 ± 0.05 mm (0.0079 ± 0.0020 in.)			
Fuel Injection Pressure	21.6 +1.0 MPa (3133 +217 psi)	19.6 +1.0 MPa (2843 +145 psi)	21.6 ± 0.5 MPa (3133 ± 72 psi)	

Test and Adjustment Specifications

Test Item	Remarks	Specification	3JH4E	4JH4AE	4JH4 - TE	4JH4 - HTE
Cylinder Compression Test	Compression Pressure	All Cylinders Approximately Same	x	x	x	x

Repair Specifications

Component	Remarks	Specification	3JH4E	4JH4AE	4JH4-TE	4JH4-HTE	
Cylinder head	Cylinder head must not be machined		x	x	x	x	
	Valve guides are not available as replacement parts						
	Combustion surface distortion		0.05 or less +0.1 mm (0.002 or less +0.004 in.)	x	x	x	x
	Top clearance		0.68 +0.12 mm (0.027 +0.005 in.)	x	x	x	x
	Valve sink		0.30 +0.20 / +0.50 mm (0.012 +0.008 / +0.020 in.)	x	x	x	x
	Standard valve guide ID - Intake		8.010 +0.015 / +0.090 mm (0.3154 +0.0006 / +0.0375 in.)	x	x		
			6.000 +0.015 / +0.100 mm (0.2362 +0.0006 / +0.0039 in.)			x	x
	Standard valve guide ID - Exhaust		8.015 +0.015 / +0.085 mm (0.3155 +0.0006 / +0.0033 in.)	x	x		
			6.000 +0.015 / +0.100 mm (0.2362 +0.0006 / +0.0039 in.)			x	x
	Valve side movement (maximum) (Valve-to-guide wear)	Intake	0.16 mm (0.0063 in.)	x	x		
			0.18 mm (0.0071 in.)			x	x
		Exhaust	0.18 mm (0.0071 in.)	x	x	x	x
	Valve seat angle	Intake	120°	x	x	x	x
		Exhaust	80°	x	x	x	x
Valve seat width	Intake	1.07 +0.17 / +0.67 mm (0.0421 +0.0067 / +0.0264 in.)	x	x	x	x	
	Exhaust	1.24 +0.21 / 0.7 mm (0.0488 +0.0083 / +0.0276 in.)	x	x	x	x	
Valves	Stem diameter	Intake	7.975 -0.020 / -0.075 mm (0.3140 -0.0008 / -0.0030 in.)	x	x		
		Exhaust	7.970 -0.015 / -0.070 mm (0.3138 -0.0006 / -0.0027 in.)	x	x		
		Intake	5.975 -0.015 / -0.060 mm (0.2352 -0.0006 / -0.0024 in.)			x	x
		Exhaust	5.960 -0.015 / -0.060 mm (0.2346 -0.0006 / -0.0024 in.)			x	x
	Valve guide projection from cylinder head		15.0 -0.3 mm (0.591 -0.0118 in.)	x	x		
			8.5 -0.3 mm (0.335 -0.0118 in.)			x	x
Valve guide driving-in method		Cold fitted	x	x	x	x	
Valve spring	Free length	44.4 / -1.4 mm (1.748 / -0.055 in.)	x	x	x	x	
		37.4 / -0.5 mm (1.472 / -0.020 in.)	x	x	x	x	
	Inclination	1.1 mm (0.043 in.)	x	x	x	x	

Component	Remarks	Specification	3JH4E	4JH4AE	4JH4-TE	4JH4-HTE	
Rocker arm and shaft	Arm shaft hole diameter	16.000 +0.020 / +0.09 mm (0.6299 +0.0008 / +0.0035 in.)	X	X	X	X	
	Shaft outside diameter	15.984 -0.018 / -0.029 mm (0.6293 -0.0007 / -0.0011 in.)	X	X	X	X	
	Clearance	0.016 +0.038 / +0.124 mm (0.0006 +0.0015 / +0.0049 in.)	X	X	X	X	
Push rod	Bend	Less than 0.03mm (Less than 0.0012 in.)	X	X	X	X	
Camshaft	Side gap	0.05 +0.15 / +0.30 mm (0.0020 +0.0059 / 0.00118 in.)	X	X	X	X	
	Bending (1/2 the dial gauge reading)	0.02 or less / +0.03 mm (0.0008 or less / +0.0012 in.)	X	X	X	X	
	Cam height	Intake / Exhaust	38.800 -0.200 / -0.450 mm (1.5276 -0.0079 / -0.0177 in.)	X	X		
		Intake	40.000 -0.200 / -0.450 mm (1.5748 -0.0079 / -0.0177 in.)			X	X
		Exhaust	38.000 -0.200 / 0.450 mm (1.4961 -0.0079 / -0.0177 in.)			X	X
	Shaft outside diameter / Metal inside diameter						
	Gear side	Bushing inside diameter	44.990 +0.065 / +0.140 mm (1.7713 +0.0026 / +0.0055 in.)	X	X	X	X
		Camshaft outside diameter	44.950 -0.025 / -0.060 mm (1.7697 -0.0010 / -0.0024 in.)	X	X	X	X
		Clearance	0.04 +0.09 / +0.20 mm (0.0697 +0.0035 / +0.0079 in.)	X	X	X	X
	Intermediate	Bushing inside diameter	45.000 +0.025 / +0.100 mm (1.7717 +0.0010 / +0.0039 in.)	X	X	X	X
		Camshaft outside diameter	44.935 -0.025 / -0.035 mm (1.7691 -0.0010 / -0.0014 in.)	X	X	X	X
		Clearance	0.065 +0.050 / +0.160 mm (0.0026 +0.0020 / +0.0063 in.)	X	X	X	X
	Flywheel end	Bushing inside diameter	45.000 +0.025 / +0.100 mm (1.7717 +0.0010 / +0.0039 in.)	X	X	X	X
Camshaft outside diameter		44.950 -0.025 / -0.060 mm (1.7697 / -0.0010 / -0.0024 in.)	X	X	X	X	
Clearance		0.05 +0.050 / +0.160 mm (0.0020 +0.0020 / +0.0063 in.)	X	X	X	X	
Idle gear shaft and bushing	Shaft outside diameter	45.975 -0.025 / -0.070 mm (1.8100 -0.0010 / -0.0028 in.)	X	X	X	X	
	Bushing inside diameter	46.000 +0.025 / +0.075 mm (1.8110 +0.0010 / +0.0030 in.)	X	X	X	X	
	Clearance	0.025 +0.050 / +0.125 mm (0.0010 +0.0010 / +0.0049 in.)	X	X	X	X	
Backlash of each gear	Crank gear, cam gear, idle gear, fuel injection pump gear and seawater pump gear	0.07 +0.08 / +0.10 mm (0.0028 +0.0031 / +0.0039 in.)	X	X	X	X	

Component	Remarks		Specification	3JH4E	4JH4AE	4JH4-TE	4JH4-HTE	
Cylinder block	Cylinder bore diameter		88.000 +0.030 / +0.200 mm (3.4646 +0.0012 / +0.0079 in.)	x	x			
			84.000 +0.030 / +0.170 mm (3.3071 +0.0012 / +0.0067 in.)			x	x	
	Cylinder bore	Roundness	0.01 or less / +0.03 mm (0.0004 or less / +0.0012 in.)	x	x	x	x	
		Inclination						
Crankshaft	Bending (1/2 the dial gauge reading)		- / +0.02 mm (- / +0.0008 in.)	x	x	x	x	
	Crank pin	Pin outside diameter	47.962 -0.010 / -0.050 mm (1.8883 -0.0004 / 0.0020 in.)	x	x	x	x	
		Metal inside diameter	48.000 +0.026 / - mm (1.8898 +0.0010 / - in.)	x	x	x	x	
		Metal thickness	1.492 +0.008 / - mm (0.05874 +0.0003 / - in.)	x	x	x	x	
		Clearance	0.038 +0.074 / +0.112 mm (0.0015 +0.0029 / 0.0044 in.)	x	x	x	x	
	Crank journal (Selective pairing)	Journal outside diameter	49.962 -0.010 / -0.060 mm (1.9670 -0.0004 / -0.0024 in.)	x	x	x	x	
		Metal inside diameter	51.000 +0.010 / - mm (2.0078 +0.0004 / - in.)	x	x	x	x	
		Metal thickness	2.010 -0.015 / - mm (0.0791 -0.0006 / - in.)	x	x	x	x	
		Clearance	0.038 +0.030 / +0.112 mm (0.0015 +0.0012 / +0.0044 in.)	x	x	x	x	
	Thrust bearings	Crankshaft side gap		0.14 +0.08 / +0.16 mm (0.0055 +0.0031 / +0.0063 in.)	x		x	x
				0.15 + 0 / + 0.07 mm (0.0059 + 0 / + 0.0028 in.)		x		
	Connecting rod	Rod big end	Side clearance	0.20 +0.20 / +0.35 mm (0.0079 +0.0079 / +0.0138 in.)	x	x	x	x
Rod small end		Piston pin bushing inside diameter	26.025 +0.013 / +0.043 mm (1.0246 +0.0003 / 0.0017 in.)	x	x			
			28.025 +0.013 / +0.043 mm (1.1033 +0.0003 / 0.0017 in.)			x	x	
		Piston pin outside diameter	26.000 -0.005 / -0.035 mm (1.0236 -0.0002 / -0.0014 in.)	x	x			
			28.000 -0.005 / -0.035 mm (1.1024 -0.0002 / -0.0014 in.)			x	x	
Clearance	0.025 +0.018 / +0.076 mm (0.0010 +0.0007 / +0.0028 in.)	x	x	x	x			
Tappet	Tappet guide hole inside diameter		12.000 +0.018 / +0.045 mm (0.4724 +0.0007 / 0.0018 in.)	x	x			
			12.000 +0.025 / +0.052 mm (0.4724 +0.0010 / +0.0020 in.)			x	x	
	Tappet stem outside diameter		11.990 -0.015 / -0.060 mm (0.4720 -0.0006 / -0.0024 in.)	x	x	x	x	
	Clearance		0.010 +0.033 / +0.080 mm (0.0004 +0.0013 / +0.0031 in.)	x	x			
			0.010 +0.040 / +0.087 mm (0.0004 +0.0016 / +0.0034 in.)			x	x	

Component	Remarks	Specification	3JH4E	4JH4AE	4JH4-TE	4JH4-HTE
Engine piston, rings and pins	Piston outside diameter (Measure in the direction vertical to the piston pin)	87.960 -0.010 / -0.060 mm (3.4630 -0.0004 / -0.0024 in.)	x			
		87.945 -0.010 / -0.060 mm (3.4624 -0.0004 / -0.0024 in.)		x		
		83.940 -0.010 / -0.060 mm (3.3047 -0.0004 / -0.0024 in.)			x	x
	Clearance between piston and cylinder	0.045 +0.03 / - mm (0.0018 +0.0012 / - in.)	x			
		0.060 +0.030 / - mm (0.0024 +0.0012 / - in.)		x		
		0.065 +0.030 / - mm (0.0026 +0.0012 / - in.)			x	x
	Piston diameter measure position (Upward from the bottom end of the piston)	22 mm (0.8661 in.)	x	x	x	x
	Piston pin hole inside diameter	26.000 +0.009 / +0.020 mm (1.0236 +0.0004 / 0.0008 in.)	x	x		
		28.000 +0.009 / +0.020 mm (1.1024 +0.0004 / 0.0008 in.)			x	x
	Piston pin outside diameter	26.000 -0.005 / -0.035 mm (1.0236 -0.0002 / -0.0014 in.)	x	x		
		28.000 -0.005 / -0.035 mm (1.1024 -0.0002 / -0.0014 in.)			x	x
	Clearance between piston and hole	0 +0.014 / +0.074 mm (0 +0.0006 / +0.0029 in.)	x	x	x	x
Top ring	Ring groove width	2.060 +0.015 / +0.110 mm (0.0811 +0.0006 / 0.0043 in.)	x	x		
		2.060 +0.020 / +0.120 mm (0.0811 +0.0008 / +0.0047 in.)			x	x
	Ring width	1.990 -0.020 / -0.040 mm (0.3685 -0.0008 / -0.0016 in.)	x	x	x	x
	Side clearance	0.070 +0.035 / +0.030 mm (0.0028 +0.0014 / +0.0012 in.)	x	x		
		(half-keystone) / -			x	x
	End clearance (gap)	0.200 -0.200 / -0.290 mm (0.0079 -0.0079 / -0.0114 in.)	x	x	x	x

Component	Remarks		Specification	3JH4E	4JH4AE	4JH4-TE	4JH4-HTE
Engine piston, rings and pins	Second ring	Ring groove width	2.025 +0.015 / +0.115 mm (0.0797 +0.0006 / +0.0045 in.)	x	x		
			2.050 +0.015 / +0.120 mm (0.0807 +0.0006 / +0.0047 in.)			x	x
		Ring width	1.990 -0.020 / -0.040 mm (0.0783 -0.0008 / -0.0016 in.)	x	x	x	x
		Side clearance	0.035 +0.035 / +0.155 mm (0.0014 +0.0014 / +0.0061 in.)	x	x		
			0.060 +0.035 / +0.160 mm (0.0024 +0.0014 / +0.0063 in.)			x	x
		End clearance (gap)	0.200 +0.200 / +0.290 mm (0.0079 +0.0079 / +0.0115 in.)	x	x	x	x
	Oil ring	Ring groove width	4.030 +0.015 / +0.100 mm (0.1587 +0.0006 / +0.0039 in.)	x	x		
			4.020 +0.015 / +0.100 mm (0.1583 +0.0006 / +0.0039 in.)			x	x
		Ring width	3.990 -0.020 / -0.040 mm (0.1571 -0.0008 / -0.0016 in.)	x	x	x	x
		Side clearance	0.025 +0.035 / +0.155 mm (0.0010 +0.0014 / +0.0061 in.)	x	x		
			0.030 +0.035 / +0.150 mm (0.0012 +0.0014 / +0.0059 in.)			x	x
		End clearance (gap)	0.200 +0.200 / +0.290 mm (0.0079 +0.0079 / +0.0114 in.)	x	x	x	x
Coolant	Coolant capacity		4.5 L (4.8 qt)	x			
			6.0 L (6.3 qt)		x		
			7.2 L (7.6 qt)			x	x
	Coolant recovery tank		0.8 L (0.85 qt)	x	x	x	x

Component	Remarks	Specification	3JH4E	4JH4AE	4JH4-TE	4JH4-HTE	
Lubricating oil	Lubricating oil capacity	Engine (with KM35P, at rake angle 8 degrees)	5.0 ±0.3 / effective 1.1 L (5.3 ±0.3 / effective 1.2 qt)	x			
		Engine (with KM35A / SD40, at rake angle 0 degrees)	5.5 ±0.3 / effective 1.2 L (5.8 ±0.3 / effective 1.3 qt)	x			
		Engine (with KM35P / ZF30M, at rake angle 8 degrees)	5.0 ±0.3 / effective 1.2 L (5.3 ±0.3 / effective 1.3 qt)		x		
		Engine (with KM35A2 / KM4A1 / SD40, at rake angle 0 degrees)	5.0 ±0.3 / effective 1.4 L (5.3 ±0.3 / effective 1.5 qt)		x		
		Engine (with ZF30F, at angle 7 degrees)	5.7 ±0.3 / effective 2.4 L (6.0 ±0.3 / effective 2.5 qt)			x	x
		Engine (with KMH4A / KM4A2 / ZF25A / SD50, at rake angle 0 degrees)	6.9 ±0.3 / effective 2.4 L (7.3 ±0.3 / effective 2.5 qt)			x	x
	Marine gear oil capacity	KM35P	0.50 L (0.53 qt)	x	x		
		KM35A	0.65 L (0.69 qt)	x	x		
		KM35A2			x		
		ZF30M	1.1 L (1.1 qt)		x		
		ZF30M	1.1 / effective 0.2 L (1.2 / effective 0.2 qt)			x	x
		KM4A1	1.3 L (1.4 qt)		x		
KMH4A		2.00/ effective 0.2 L (2.1 / effective 0.2 qt)			x	x	
KM4A2							
Marine gear oil capacity	ZF25A	1.8 L (1.9 qt)			x	x	
	SD50-4T	2.2 / effective 0.1 L (2.3 / effective 0.1 qt)			x		
Lubricating oil pressure			0.54 -0.15 / -0.48 MPa or above (78 -22 / -67 psi or above)	x	x		
			0.45 -0.17 / -0.39 MPa or above (65 -25 / -57psi or above)			x	x

Component	Remarks	Specification	3JH4E	4JH4AE	4JH4-TE	4JH4-HTE		
Lubricating oil system (Trochoid pump)	Outside clearance of outer rotor	0.12 +0.09 / +0.18 mm (0.0047 +0.0035 / +0.0071 in.)		x	x			
		0.09 +0.07 / - mm (0.0035 +0.0028 / - in.)				x	x	
	Tip clearance between outer rotor and inner rotor	- / 0.16 mm (- / 0.0063 in.)		x	x	x	x	
	Side clearance of outer rotor	0.05 +0.05 / +0.10 mm (0.0020 +0.0020 / +0.0040 in.)		x	x	x	x	
	Standard parts size							
	Inside clearance of inner rotor	Gear boss diameter	53.05 +0.10 mm (2.089 +0.004 in.)	0.3 +0.2 / +0.3 mm (0.012 +0.008 / +0.012 in.)	x	x	x	x
		Rotor diameter	53.45 +0.10 mm (2.104 +0.004 in.)		x	x	x	x
	Width across flat clearance of inner rotor	Width across flat of gear boss	49.45 +0.30 mm (1.947 +0.008 in.)	0.2 +0.4 / +0.5 mm (0.008 +0.016 / +0.020 in.)	x	x	x	x
		Width across flat of rotor	49.95 +0.10 mm (1.967 +0.004 in.)		x	x	x	x
	Thermostat	Valve opening temperature	75 +3 degree °C (167 +5 degree °F)		x	x	x	x
Full opening lift at specified temperature		8 mm or above at 90 degree °C (0.3 in. or above at 194 degree °F)		x	x	x	x	
Thermo switch actuating temperature		ON	97 +6 degree °C (207 +11 degree °F)		x	x	x	x
		OFF	90 degree °C or more (194 degree °F or more)		x	x	x	x

SPECIAL TORQUE CHART

System	Component	Model	Thread	Comments	Specification
Engine Block	Metal Cap Bolt	3JH4 4JH4	M12 x1.5	Coat with lubricating oil	98 ± 2 N·m (72 + 1.5 lb-ft)
Connecting Rod and Bearing	Connecting Rod Bolts	3JH4 4JH4	M9 x1.0	Coat with lubricating oil	44.1 + 5.0 N·m (32.5 + 3.7 lb-ft)
Cylinder Head	Cylinder Head Bolts	3JH4 4JH4	M10 x1.25	Coat with lubricating oil	88.2 ± 3.0 N·m (65.1 + 2.2 lb-ft)
Crankshaft	Flywheel Bolt	3JH4 4JH4	M10 x1.25	Coat with lubricating oil	83.3 + 5.0 N·m (61.4 + 3.7 lb-ft)
	Pulley Bolt (FC300 Pulley)	3JH4 4JH4	M12 x1.5	Coat with lubricating oil	88.2 ± 5.0 N·m (65 ± 3.7 lb-ft)
Lubricating System	Plate machine bolt (Lubricating Oil Cover)	4JH4AE	M6 x1.0	No lubricating oil	6.9 ± 1.5 N·m (4.8 ± 1.1 lb-ft)
Fuel System	Nozzle Retainer Bolt	3JH4 4JH4	M8 x1.25	No lubricating oil	26.4 ± 2.0 N·m (19.5 ± 1.5) lb-ft
	Fuel Injection Pump Drive Gear Nut	4JH4AE	M8 x1.0	No lubricating oil	34.3 ± 2.0 N·m (25.3 ± 1.5 lb-ft)
		4JH4-TE 4JH4-HTE	M14 x1.5	Coat with lubricating oil	59 + 10 N·m (44 + 7.4 lb-ft)
	Fuel Injection Line Joint Nut	3JH4 4JH4	M12 x1.5	No lubricating oil	29.4 + 5.0 N·m (21.5 + 3.7 lb-ft)
	Fuel Return Line Bolts	4JH4AE	M6 x1.0	No lubricating oil	7.8 + 4.0 N·m (69 + 18 lb-ft)
	Fuel Injection Pump Mounting Nuts	4JH4	M8 x1.25	No lubricating oil	23 + 5 N·m (17 + 4 lb-ft)
	Fuel Injection Nozzle Case Nuts	4JH4AE	0.605-40 UNS-28	No lubricating oil	39.2 + 4.9 N·m (30 + 3 lb-ft)
	Fuel Injection Pump Plunger Plug	4JH4AE	M14 x1.0	No lubricating oil	30 + 5 N·m (22 + 4 lb-ft)
Electrical System	Starter Relay Terminal Nut (Magnetic Relay)	3JH4 4JH4	M6 x1.0	No lubricating oil	3.6 ± 0.6 N·m (2.7 ± 0.45 lb-ft)

STANDARD TORQUE CHART (WITHOUT LUBRICATING OIL)

Name	Thread	Specification	Comments
Hexagon bolt with a "7" mark head and hexagon nut ("7" mark means JIS strength classification "7T".)	M6 x1	9.8 + 2.0 N·m (7.2 + 1.5 lb-ft)	Apply 80% torque when tightening to aluminum alloy. Apply 60% torque to 4T bolts and locknuts.(4T bolt has no mark on the head)
	M8 x1.25	22.5 + 6.0 N·m (16.6 + 4.4 lb-ft)	
	M10 x1.5	44 + 6.0 N·m (37 + 4.4 lb-ft)	
	M12 x1.75	78.2 + 10 N·m (57.7 + 7.4 lb-ft)	
PT plug (Taper plug)	1/8	9.8 N·m (7.2 lb-ft)	When lock adhesive is applied, decide separately.
	1/4	19.6 N·m (14.5 lb-ft)	
	3/8	29.4 N·m (21.7 lb-ft)	
	1/2	58.8 N·m (43.4 lb-ft)	
Line joint bolt	M8	12.7 + 4.0 N·m (9.4 + 3.0 lb-ft)	
	M10	19.5 + 6.0 N·m (14.3 + 4.4 lb-ft)	
	M12	24.4 + 10 N·m (18.0 + 7.4 lb-ft)	
	M14	39.1 + 10 N·m (28.8 + 7.4 lb-ft)	
	M16	48.9 + 10 N·m (36.1 + 7.4 lb-ft)	

SPECIAL SERVICE TOOLS

The following tools are required when disassembling and reassembling the engine.

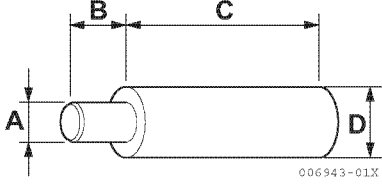
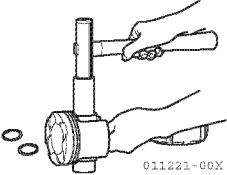
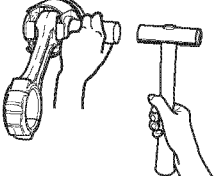
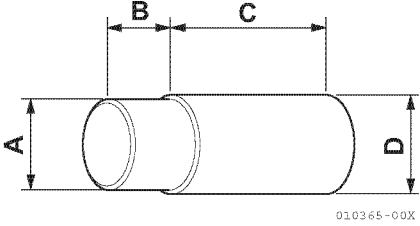
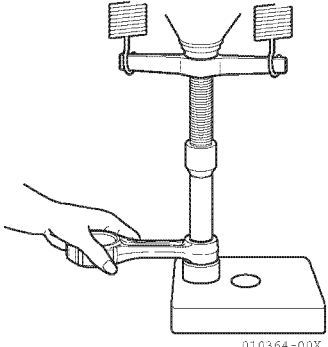

Please use them as instructed.

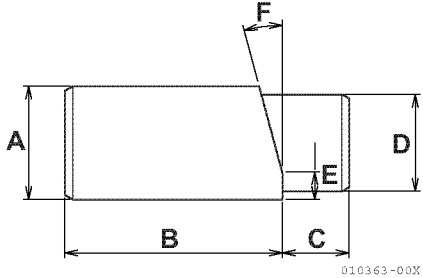
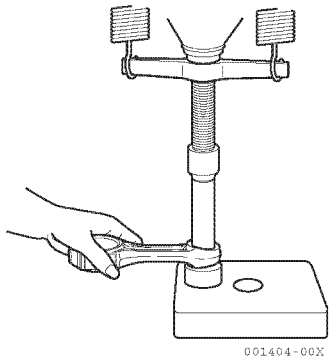
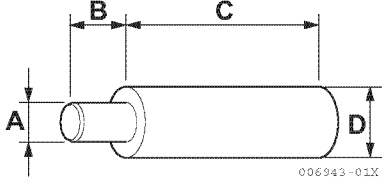
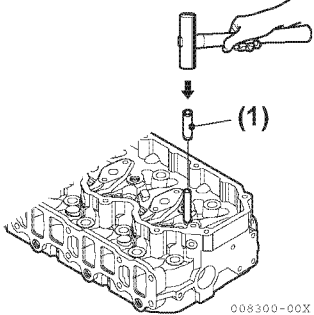
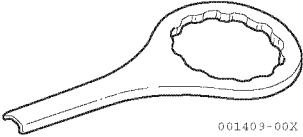
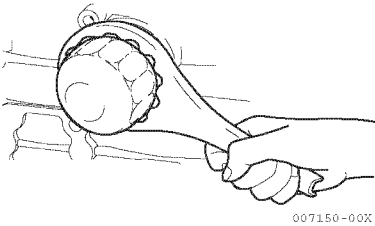
No.	Tool Name Applicable Model	Applicable Model and Tool Size	Illustration															
1	Piston pin insertion / extraction tool	 <table border="1" data-bbox="376 629 1018 750"> <thead> <tr> <th></th> <th>A</th> <th>B</th> <th>C</th> <th>D</th> </tr> </thead> <tbody> <tr> <td>MM</td> <td>12</td> <td>20</td> <td>80</td> <td>25</td> </tr> <tr> <td>IN.</td> <td>0.472</td> <td>0.787</td> <td>3.150</td> <td>0.984</td> </tr> </tbody> </table>		A	B	C	D	MM	12	20	80	25	IN.	0.472	0.787	3.150	0.984	<p>Extraction of piston pin</p>  <p>011221-00X</p> <p>Insertion of piston pin</p>  <p>011222-00X</p>
	A	B	C	D														
MM	12	20	80	25														
IN.	0.472	0.787	3.150	0.984														
2	Connecting rod small end bushing insertion / extraction tool for 3JH4E / 4JH4TE	 <table border="1" data-bbox="376 1182 1018 1303"> <thead> <tr> <th></th> <th>A</th> <th>B</th> <th>C</th> <th>D</th> </tr> </thead> <tbody> <tr> <td>MM</td> <td>25.4-25.7</td> <td>20</td> <td>80</td> <td>28.4-28.7</td> </tr> <tr> <td>IN.</td> <td>1.000-1.012</td> <td>0.787</td> <td>3.150</td> <td>1.118-1.130</td> </tr> </tbody> </table>		A	B	C	D	MM	25.4-25.7	20	80	28.4-28.7	IN.	1.000-1.012	0.787	3.150	1.118-1.130	<p>Extraction</p>  <p>010364-00X</p>
	A	B	C	D														
MM	25.4-25.7	20	80	28.4-28.7														
IN.	1.000-1.012	0.787	3.150	1.118-1.130														

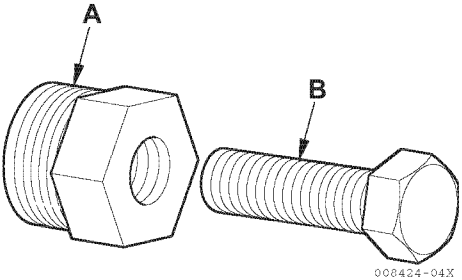
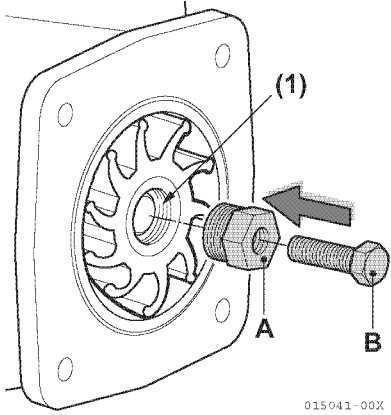
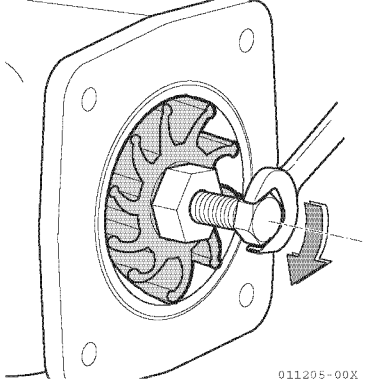
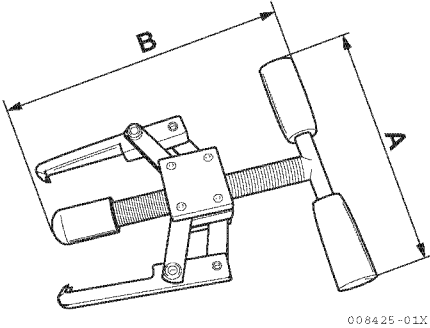
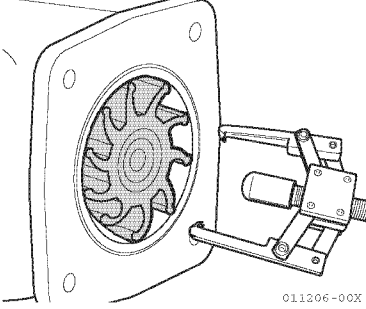
No.	Tool Name Applicable Model	Applicable Model and Tool Size	Illustration															
3	Connecting rod small end bushing insertion/extraction tool for 4JH4-TE / 4JH4-HTE	 <p>010363-00X</p>	<p>Extraction</p>  <p>001404-00X</p>															
4	Intake / Exhaust valve guide insertion/extraction tool	 <p>006943-01X</p> <table border="1" data-bbox="464 987 1086 1111"> <thead> <tr> <th></th> <th>A</th> <th>B</th> <th>C</th> <th>D</th> </tr> </thead> <tbody> <tr> <td>MM</td> <td>7.5</td> <td>20</td> <td>75</td> <td>11</td> </tr> <tr> <td>IN.</td> <td>0.295</td> <td>0.787</td> <td>2.953</td> <td>0.433</td> </tr> </tbody> </table>		A	B	C	D	MM	7.5	20	75	11	IN.	0.295	0.787	2.953	0.433	 <p>008300-00X</p> <p>1 – Tool</p>
	A	B	C	D														
MM	7.5	20	75	11														
IN.	0.295	0.787	2.953	0.433														
5	Lubricating oil filter case remover	 <p>001403-00X</p>	 <p>007150-00X</p>															

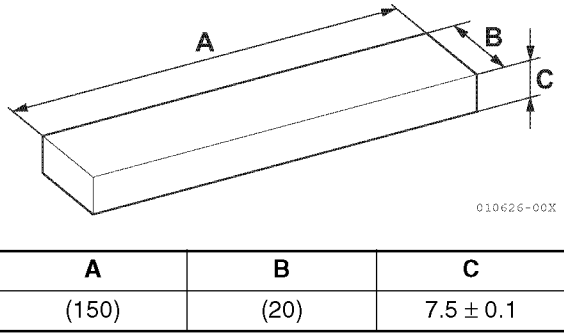
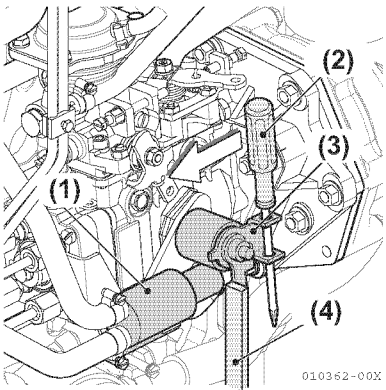
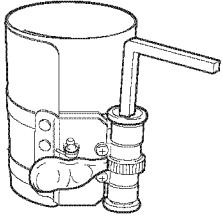
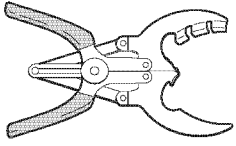
No.	Tool Name Applicable Model	Applicable Model and Tool Size	Illustration				
6	Puller A (standard) for seawater pump impeller	Puller A: 129671-92110 (standard)  <table border="1" data-bbox="416 600 979 680"> <thead> <tr> <th>A</th> <th>B</th> </tr> </thead> <tbody> <tr> <td>M18 x 1.5</td> <td>M10-length 40 mm</td> </tr> </tbody> </table>	A	B	M18 x 1.5	M10-length 40 mm	 <p>1 – M18 x 1.5 threaded</p> 
A	B						
M18 x 1.5	M10-length 40 mm						
7	Puller B (option) for seawater pump impeller	Puller B: 129671-92100 (option)  <table border="1" data-bbox="416 1644 979 1724"> <thead> <tr> <th>A</th> <th>B</th> </tr> </thead> <tbody> <tr> <td>Around 110</td> <td>Around 140</td> </tr> </tbody> </table> <p style="text-align: right;">mm</p>	A	B	Around 110	Around 140	
A	B						
Around 110	Around 140						

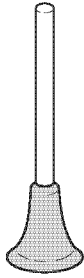
No.	Tool Name Applicable Model	Applicable Model and Tool Size	Illustration						
8	C.S.D. cancel spacer for the adjustment of fuel injection timing	Spacer: 129671-51990  <table border="1" data-bbox="491 510 1066 591"> <thead> <tr> <th>A</th> <th>B</th> <th>C</th> </tr> </thead> <tbody> <tr> <td>(150)</td> <td>(20)</td> <td>7.5 ± 0.1</td> </tr> </tbody> </table>	A	B	C	(150)	(20)	7.5 ± 0.1	 <p>010626-00X</p> <p>010362-00X</p> <p>1 – Wax pellet 2 – Screwdriver 3 – C.S.D. lever 4 – Spacer</p>
A	B	C							
(150)	(20)	7.5 ± 0.1							
9	Piston ring compressor	 <p>007236-00X</p>							
10	Piston ring replacer (for removal / insertion of piston ring)	 <p>001411-00X</p>							

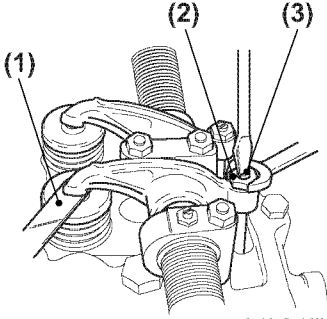
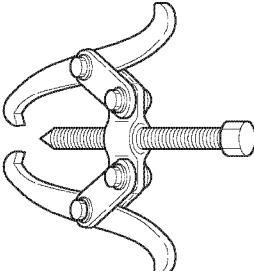
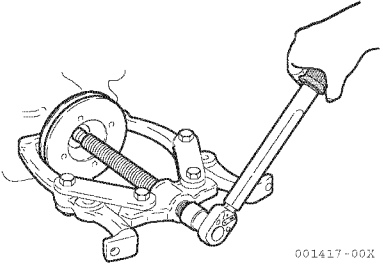

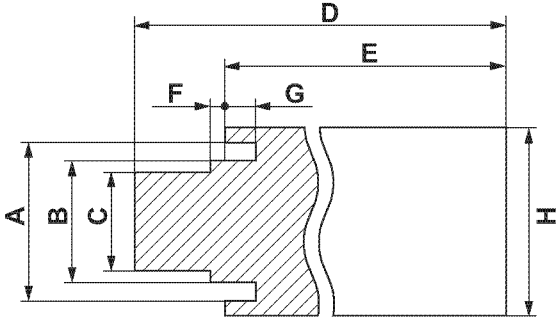
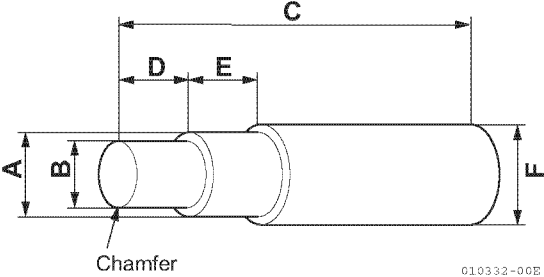
No.	Tool Name Applicable Model	Applicable Model and Tool Size	Illustration
11	Valve lapping tool (Rubber cap type)	 <p>001412-00X</p>	
12	Valve lapping powder	 <p>001413-00X</p>	
13	Feeler gauge	 <p>001414-00X</p>	 <p>011215-00X</p> <p>1 – Feeler gauge 2 – Locknut 3 – Adjusting bolt</p>
14	Pulley puller	<p>Local supply</p>  <p>001416-01E</p>	<p>Removing the coupling</p>  <p>001417-00X</p>

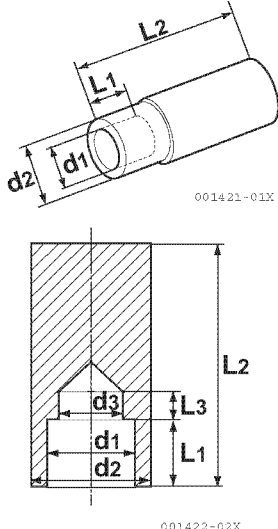
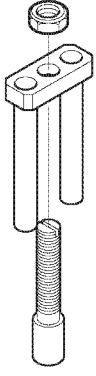
No.	Tool Name Applicable Model	Applicable Model and Tool Size	Illustration																											
15	Press tool 1 for filler neck	<p data-bbox="456 221 528 241">Tool 1</p>  <p data-bbox="951 584 1034 600">010331-00X</p> <table border="1" data-bbox="451 613 1098 725"> <thead> <tr> <th></th> <th>A</th> <th>B</th> <th>C</th> <th>D</th> <th>E</th> <th>F</th> <th>G</th> <th>H</th> </tr> </thead> <tbody> <tr> <td>MM</td> <td>ø35.5</td> <td>ø27.5</td> <td>ø25</td> <td>105</td> <td>89</td> <td>1</td> <td>2</td> <td>ø40</td> </tr> <tr> <td>IN.</td> <td>1.397</td> <td>1.082</td> <td>.984</td> <td>4.133</td> <td>3.503</td> <td>.039</td> <td>.078</td> <td>1.574</td> </tr> </tbody> </table>		A	B	C	D	E	F	G	H	MM	ø35.5	ø27.5	ø25	105	89	1	2	ø40	IN.	1.397	1.082	.984	4.133	3.503	.039	.078	1.574	
	A	B	C	D	E	F	G	H																						
MM	ø35.5	ø27.5	ø25	105	89	1	2	ø40																						
IN.	1.397	1.082	.984	4.133	3.503	.039	.078	1.574																						
16	Press tool 2 for filler neck copper tube	<p data-bbox="456 824 528 844">Tool 2</p>  <p data-bbox="612 1133 695 1153">Chamfer</p> <p data-bbox="979 1144 1062 1160">010332-00E</p> <table border="1" data-bbox="472 1205 1094 1317"> <thead> <tr> <th></th> <th>A</th> <th>B</th> <th>C</th> <th>D</th> <th>E</th> <th>F</th> </tr> </thead> <tbody> <tr> <td>MM</td> <td>ø28</td> <td>ø24.2</td> <td>170</td> <td>30</td> <td>30</td> <td>ø30</td> </tr> <tr> <td>IN.</td> <td>1.102</td> <td>.952</td> <td>6.692</td> <td>1.181</td> <td>1.181</td> <td>1.181</td> </tr> </tbody> </table>		A	B	C	D	E	F	MM	ø28	ø24.2	170	30	30	ø30	IN.	1.102	.952	6.692	1.181	1.181	1.181							
	A	B	C	D	E	F																								
MM	ø28	ø24.2	170	30	30	ø30																								
IN.	1.102	.952	6.692	1.181	1.181	1.181																								

No.	Tool Name Applicable Model	Applicable Model and Tool Size	Illustration																					
17	Stem seal insertion (for inserting stem seal)	 <p>001421-01X</p> <p>001423-02X</p> <table border="1" data-bbox="395 828 1010 952"> <thead> <tr> <th></th> <th>d1</th> <th>d2</th> <th>d3</th> <th>L1</th> <th>L2</th> <th>L3</th> </tr> </thead> <tbody> <tr> <td>MM</td> <td>16.2</td> <td>22</td> <td>13.5</td> <td>18.8</td> <td>65</td> <td>4</td> </tr> <tr> <td>IN.</td> <td>0.638</td> <td>0.866</td> <td>0.531</td> <td>0.740</td> <td>2.559</td> <td>0.157</td> </tr> </tbody> </table>		d1	d2	d3	L1	L2	L3	MM	16.2	22	13.5	18.8	65	4	IN.	0.638	0.866	0.531	0.740	2.559	0.157	
	d1	d2	d3	L1	L2	L3																		
MM	16.2	22	13.5	18.8	65	4																		
IN.	0.638	0.866	0.531	0.740	2.559	0.157																		
18	Fuel nozzle extraction tool	 <p>010333-00X</p> <table border="1" data-bbox="512 1469 895 1552"> <tr> <td>Part No.</td> </tr> <tr> <td>129470-92300</td> </tr> </table>	Part No.	129470-92300																				
Part No.																								
129470-92300																								

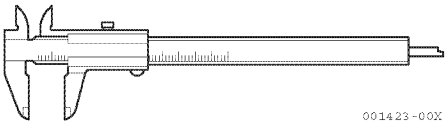
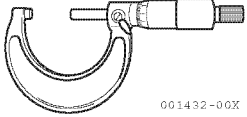
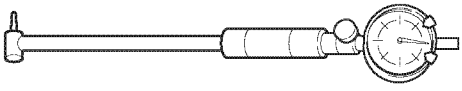
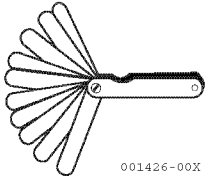
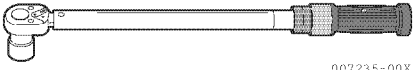
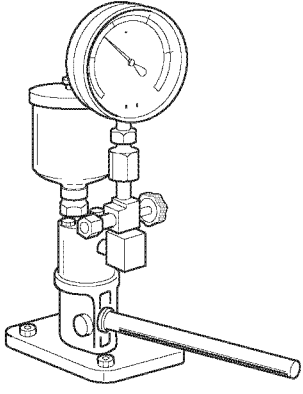
MEASURING INSTRUMENTS

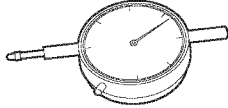
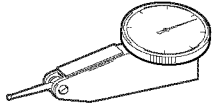
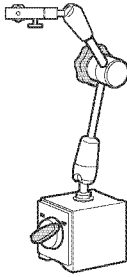
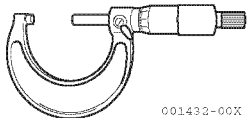
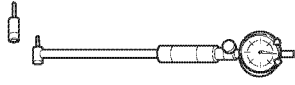
No.	Name of tool	Use	Illustration
1	Vernier calipers	0.05 mm 0-150 mm	 <p>001423-00X</p>
2	Micrometer	0.01 mm 0-25 mm 25-50 mm 50-75 mm 75-100 mm 100-125 mm 125-150 mm	 <p>001432-00X</p>
3	Cylinder gauge	0.01 mm 18-35 mm 35-60 mm 50-100 mm	 <p>001425-00X</p>
4	Thickness gauge	0.05-2 mm	 <p>001426-00X</p>
5	Torque wrench	128 N·m (0-13 kgf·m)	 <p>007235-00X</p>
6	Nozzle tester	0-49 Mpa (0-500 kgf/cm ²)	 <p>010640-00X</p>

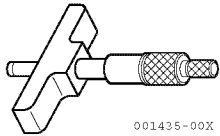
No.	Name of tool	Use	Illustration
7	Dial gauge	Measures shaft bending, distortions of levelness, and gaps.	 <p>001429-00X</p>
8	Test indicator	Measures narrow and deep places, which cannot be measured with dial gauge.	 <p>001430-00X</p>
9	Magnetic stand	Keeps the dial gauge firmly in position, thereby permitting it to be used at various angles.	 <p>001431-00X</p>
10	Micrometer	Measures the outer diameter of the crankshaft, piston, piston pin, etc.	 <p>001432-00X</p>
11	Cylinder gauge	Measure the inner diameter of the cylinder liner and rod metal.	 <p>001433-00X</p>
12	Vernier calipers	Measures various outer diameter, thickness, and width.	 <p>001434-00X</p>
13	Depth micrometer	Measures sinking of valves.	 <p>001435-00X</p>

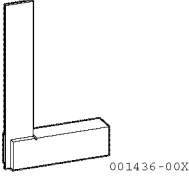
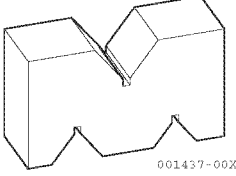
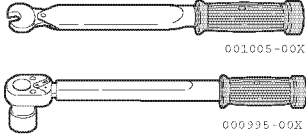
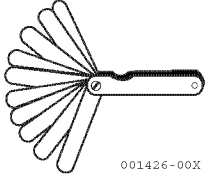
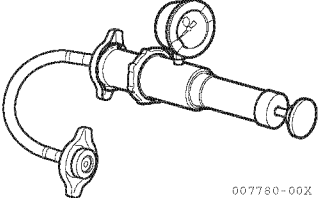
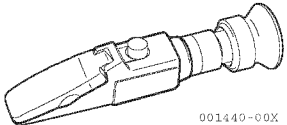
No.	Name of tool	Use	Illustration
14	Square	Measures distortion in position of springs and perpendicularity of parts.	
15	V Block	Measures shaft distortion.	
16	Torque wrench	Used to tighten bolts and nuts to standard torque.	
17	Thickness gauge	Measures the distance between the ring and ring groove, and between the shaft and shaft joint at time of assembling.	
18	Cap tester	Check for leakage in the freshwater system.	
19	Battery current tester	Checks density of antifreeze and charging condition of battery fluid.	

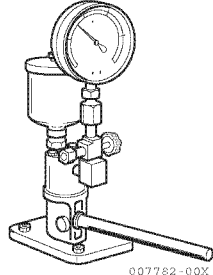
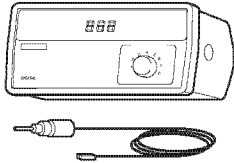
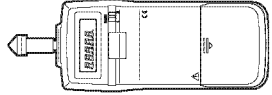
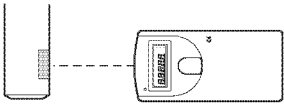
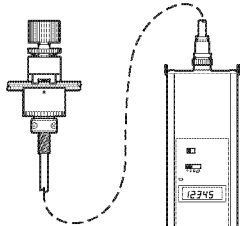
No.	Name of tool		Use	Illustration
20	Nozzle tester		Checks the shape and pressure of spray emitted from the fuel injection valve at the time of injection.	 <p>007782-00X</p>
21	Digital thermostat		Measures temperature of various parts.	 <p>001442-01X</p>
22	Rotation gauge	Contact type	Measures rotation speed by using a reflector seal which is placed on the exterior of the revolving shaft.	 <p>001443-00X</p>
		Photoelectric type	Measures rotation speed by using a reflector seal which is placed on the exterior of the revolving shaft.	 <p>001444-01X</p>
		High-pressure fuel pipe clamp type	Measures rotation speed without reference to revolving shaft center or the exterior of the revolving shaft.	 <p>001445-01X</p>

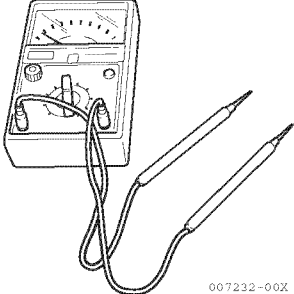
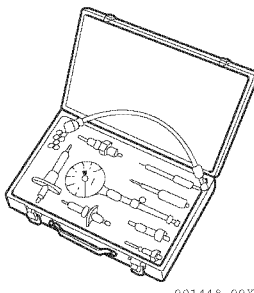
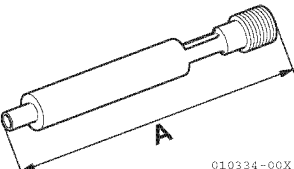
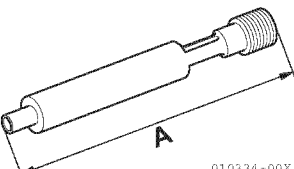
No.	Name of tool	Use	Illustration		
23	Circuit tester	Measure the resistance, voltage, and continuity of the electric circuit.	 <p>007232-00X</p>		
24	Compression gauge	Measures the pressure of the compression. <table border="1" data-bbox="635 638 1015 719"> <tr> <td>Gauge set code No.</td> </tr> <tr> <td>TOL-97190080</td> </tr> </table>	Gauge set code No.	TOL-97190080	 <p>001448-00X</p>
		Gauge set code No.			
		TOL-97190080			
Adapter for direct injection 2-valve head. <table border="1" data-bbox="635 1003 1015 1084"> <tr> <td>Adapter code No.</td> </tr> <tr> <td>119802-92950</td> </tr> </table>	Adapter code No.	119802-92950	 <p>010334-00X</p> <table border="1" data-bbox="1193 1137 1348 1218"> <tr> <td>A</td> </tr> <tr> <td>130</td> </tr> </table>	A	130
Adapter code No.					
119802-92950					
A					
130					
Adapter for direct injection 4-valve head. <table border="1" data-bbox="635 1400 1015 1480"> <tr> <td>Adapter code No.</td> </tr> <tr> <td>129906-92950</td> </tr> </table>	Adapter code No.	129906-92950	 <p>010334-00X</p> <table border="1" data-bbox="1193 1529 1348 1610"> <tr> <td>A</td> </tr> <tr> <td>165</td> </tr> </table>	A	165
Adapter code No.					
129906-92950					
A					
165					

SEALANTS AND COMPOUNDS

No.	Items	Usual contents	Features and application	
1	Liquid gasket	Three Bond No. 1 TB1101	200 g (1 kg also available)	Non-drying liquid gasket; solvent less type, easy to remove, superior in seawater resistance, applicable to various mating surfaces.
		Three Bond No. 2 TB1102	200 g (1 kg also available)	Non-drying liquid gasket; easy to apply, superior in water resistance and oil resistance, especially superior in gasoline resistance.
		Three Bond No. 3 TB1103	150 g	Drying film, low viscosity and forming of thin film, appropriate for mating surface of precision parts.
		Three Bond No. 4 TB1104	200 g (1 kg also available)	Semi-drying viscoelastic material, applicable to non-flat surface having many indentations and protrusions, superior in heat resistance, water resistance, and oil resistance.
		Three Bond No. 10 TB1211	100 g	Solvent-less type silicone-base sealant, applicable to high temperature areas. (-50 °C to 250)
		Three Bond TB1212	100 g	Silicone-base, non-fluid type, thick application possible.
2	Adhesive	Three Bond TB1401	200 g	Prevention of loose bolts, gas leakage, and corrosion. Torque required to loosen bolt: 10 to 20% larger than tightening torque.
		Lock tight SUPER TB1324	50 g	Excellent adhesive strength locks bolt semi-permanently.
3	Seal Tape	5 m round tape	Sealing material for threaded parts of various pipes. Ambient temperature range: -150 °C to 200 °C	
4	O-ring kit	Ø1.9 x 2 m: 1 Ø2.4 x 2 m: 1 Ø3.1 x 2 m: 1 Ø3.5 x 2 m: 1 Ø5.7 x 2 m: 1	O-ring of any size can be prepared, whenever required. (Including adhesive, release agent, cutter, and jig)	
5	EP lubricant (molybdenum disulfate)	Brand name (LOWCOL PASTE)	50 g	For assembly of engine cylinders, pistons, metals shafts, etc. Spray type facilitates application work.
		Brand name (PASTE SPRAY)	330 g	
		Brand name (MOLYPASTE)	50 g	Prevention of seizure of threaded parts at high temperature. Applicable to intake / exhaust valves. (stem, guide, face)

No.	Items		Usual contents	Features and application
5	Scale solvent	Scale solvent	1 box (4 kg x 4 removers)	<ul style="list-style-type: none"> The scale solvent removes scale in a short time. (1 to 10 hours) Prepare water (seawater is possible) in an amount that is about 10 times the weight of the solvent. Mix the solvent with water. Just dipping disassembled part into removes scale. To shorten removal time, stir remover mixture. If cleaning performance drops, replace remover mixture with new remover mixture. Neutralize used mixture, and then dispose of it. To judge cleaning performance of mixture, put pH test paper into mixture. If test paper turns red, remover mixture is still effective.
		Neutralizer (caustic soda)	1 box (2 kg x 4 neutralizers)	
		pH test paper		
6	Anti freeze			Add antirust to freshwater system at the cold area to engine operate.
7	Cleaning agent			<ul style="list-style-type: none"> The cleaning agent removes even carbon adhering to disassembled parts. If a cleaning machine is used, prepare 4 to 6% mixture of 60° to 80° to ensure more effective cleaning.
8	Cleaning agent for turbocharger		4l x 4	Special cleaning agent that requires no water, specially designed for blower of turbocharger and intercooler.
			18l x 1	
			15sets: 1, 500cc x 6	

NOTICE: It is recommended that liquid gasket Three Bond® TB1212 should be used for service work. Before providing service, observe the cautions below:

- Build up each sealant bead equally.
- For bolt holes, apply liquid gasket to the inside surface of each hole.
- Three Bond® TB1104 (Gray) or Three Bond® TB1102 (Yellow) is used with a gasket. The use of either of these sealant bonds without a gasket alone is not effective.
- If a gasket is used, do not use sealant TB1212 (Figure 5-1).

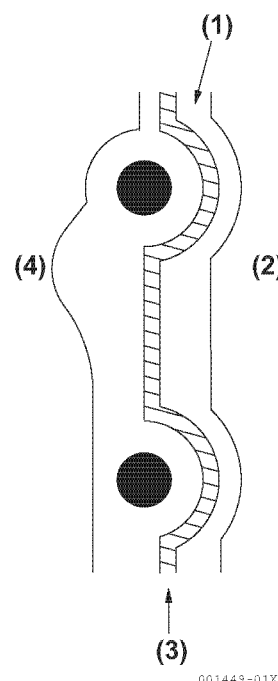

Figure 5-1

- 1 – Oil pan mating surface
- 2 – Inside of oil pan
- 3 – Bead of TB1212
- 4 – Outside

TESTS AND ADJUSTMENTS

Test Compression

The compression tester is used to quickly and simply check wear and damage primarily to the cylinder head valves, but also to cylinders and piston rings.

The results are intended only for comparison between the cylinders. Lower compression in one or more of the cylinders is a sign of abnormal wear or damage. *NOTICE: The battery must have an adequate charge in order to carry out a reliable compression test. If necessary, connect an additional battery.*

1. Disconnect electrical connectors from all fuel injectors.
2. Turn engine over several times using the starter motor to remove any loose debris in the cylinders.

3. Turn engine with the starter motor until reading on gauge stabilizes. Note the reading on the gauge.
4. Reset gauge and repeat procedure with the remaining cylinders.
5. Connect fuel injector electrical connectors.
6. Evaluate readings and assess if engine repair is necessary. If one or more cylinders have a lower compression pressure, components such as valves, cylinders and piston rings should be inspected. awaiting test specs.

Specification

Item	Cylinder Compression Pressure
3JH4E 4JH4AE 4JH4-TE	3.4 ± 0.1 MPa (493 ± 14.5 psi)
4JH4-HTE	3.2 ± 0.1 MPa (464 ± 14.5 psi)

DISASSEMBLY

If the engine is to be completely disassembled, perform the following preliminary steps:

1. Disconnect battery cables at the battery. Always disconnect negative (-) battery cable first.
2. Close all valves in fuel supply line.
3. Remove electrical connections, intake / exhaust system connections, and fuel supply lines from engine. Cap or plug all open fuel connections.
4. Drain engine coolant.
 - Open the seawater drain cock(s) to drain the seawater.

Note: Open the drain cock on the clutch cooler for 4JH4AE, 4JH4-TE and 4JH4-HTE.

- Open the three cocks for freshwater and drain the freshwater.

Note: One drain cock is behind the belt cover only for 3JH4E and 4JH4AE.
Remove the belt cover and open the drain cock.

Model	Drain cocks in Freshwater line	Drain cocks in Seawater line
3JH4E	2 cocks	2 places (1 cock and a side cover of seawater pump)
4JH4AE	2 cocks	(Figure 5-2), (Figure 5-3), (Figure 5-4), (Figure 5-5)
4JH4-TE/ 4JH4-HTE	3 cocks	3 places (1 cock, a side cover of seawater pump and 1 cock on marine gear cooler) Note1 (Figure 5-6), (Figure 5-7), (Figure 5-8), (Figure 5-9)

Note1: The marine gear coolers with a drain cock are as follows;

4JH4AE: ZF30M, KM4A1

4JH4-TE and 4JH4-HTE: ZF30M, KM4A2, KMH4A

3JH4E Engine

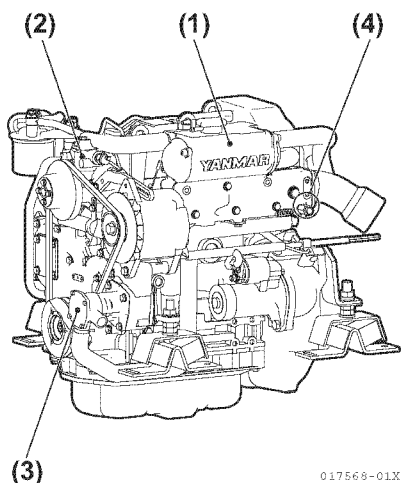

Figure 5-2

- 1 – Coolant Tank (Heat Exchanger)
- 2 – Coolant Pump (Freshwater)
- 3 – Seawater Drain from Seawater Pump Cover
- 4 – Coolant Drain Cock

4JH4AE Engine

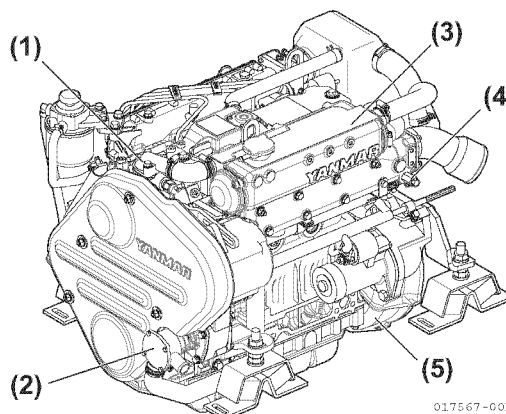

Figure 5-4

- 1 – Coolant Pump (Freshwater)
- 2 – Seawater Pump
- 3 – Coolant Tank (Heat Exchanger)
- 4 – Coolant Drain Cock
- 5 – Seawater Drain from Seawater Pump Cover

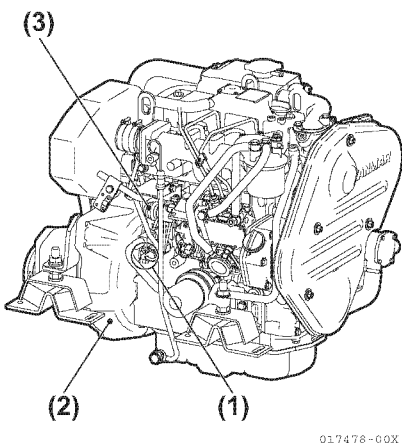

Figure 5-3

- 1 – Coolant Drain Cock
- 2 – Flywheel Housing
- 3 – Stop Solenoid

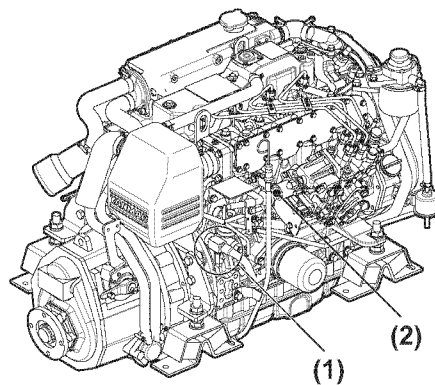

Figure 5-5

- 1 – Coolant Drain Cock
- 2 – Stop Solenoid

4JH4-TE Engine

4JH4-HTE Engine

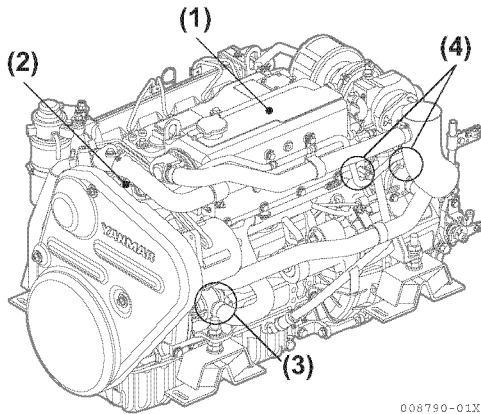

Figure 5-6

- 1 – Coolant Tank (Heat Exchanger)
- 2 – Coolant Pump (Freshwater)
- 3 – Seawater Drain from Seawater Pump Cover
- 4 – Coolant Drain Cock (2 used)

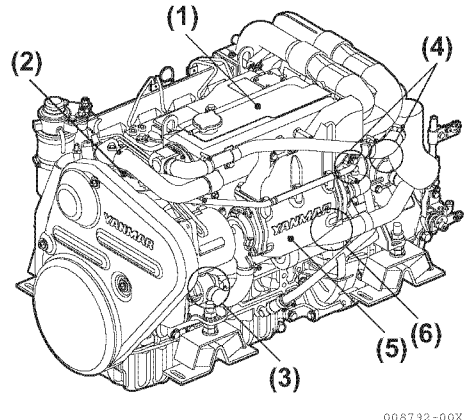

Figure 5-8

- 1 – Coolant Tank (Heat Exchanger)
- 2 – Coolant Pump (Freshwater)
- 3 – Seawater Drain from Seawater Pump Cover
- 4 – Coolant Drain Cock
- 5 – Intercooler
- 6 – Seawater Drain from Heat Exchanger

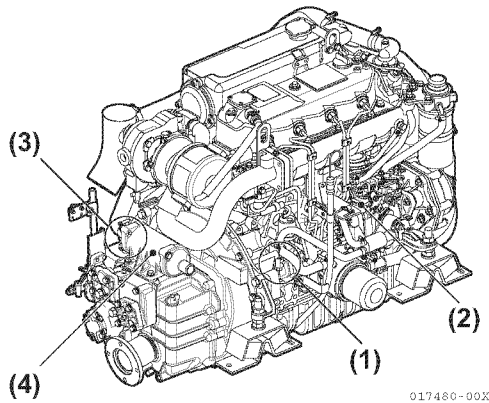

Figure 5-7

- 1 – Coolant Drain Cock
- 2 – Fuel Pump
- 3 – Seawater Drain Cock
- 4 – Marine Gear Cooler

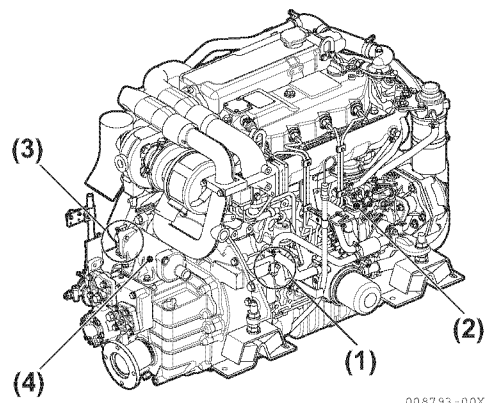

Figure 5-9

- 1 – Coolant Drain Cock
- 2 – Fuel Pump
- 3 – Seawater Drain Cock
- 4 – Marine Gear Cooler

5. Remove the engine from the boat. Mount the engine to a suitable engine repair stand having adequate weight capacity.
6. Cap or plug all openings to prevent contamination.
7. Remove the starting motor from the flywheel housing (**Figure 5-10**).

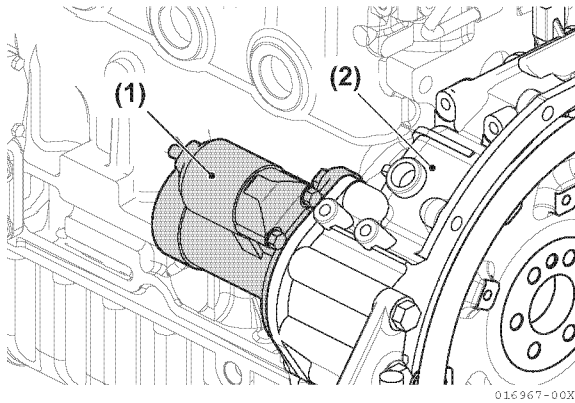

Figure 5-10

- 1 – Starting Motor
- 2 – Flywheel Housing

8. Loosen the alternator adjuster bolt and remove the V-belt.
9. Removing the adjuster from the freshwater pump, and remove the alternator from the gear case (with spacer) (**Figure 5-11**).

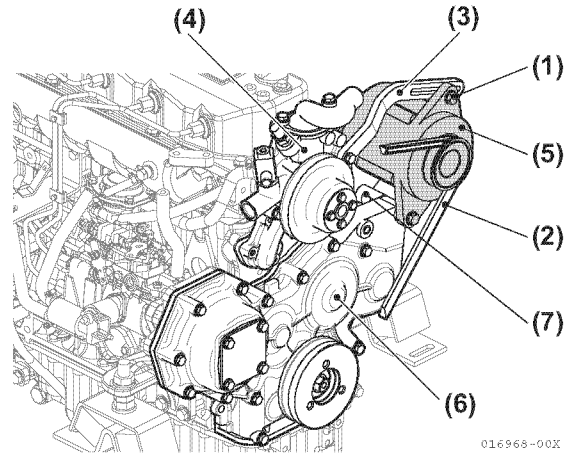

Figure 5-11

- 1 – Alternator Adjust Bolt
- 2 – V-belt
- 3 – Adjuster
- 4 – Freshwater Pump
- 5 – Alternator
- 6 – Gear Case
- 7 – With Distance Piece

10. Clean engine by washing with solvent, air or steam cleaning. **CAUTION! Ensure foreign matter or fluids do not contaminate the engine, fuel system or electrical components.**
11. Remove the fuel pipes (fuel filter-fuel feed pump, fuel filter-fuel injection pump and fuel nozzle-fuel filter).

12. Remove the fuel filter (Figure 5-12) and (Figure 5-13).

3JH4E Engine Shown

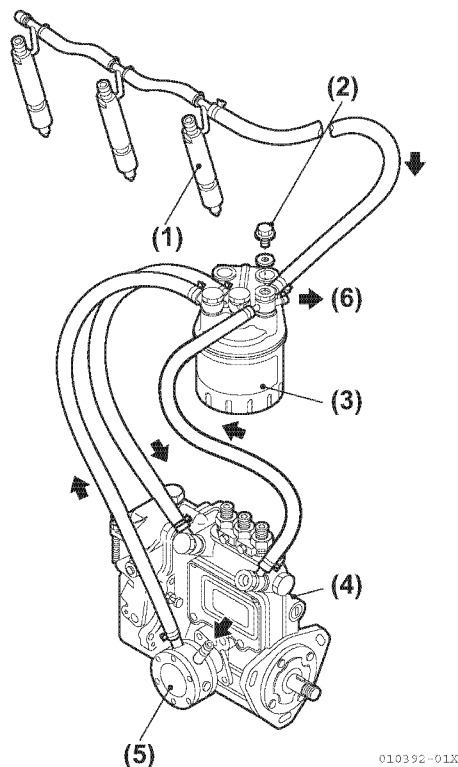

Figure 5-12

- 1 – Fuel Nozzle
- 2 – Air Bleeding Bolt
- 3 – Fuel Filter
- 4 – Fuel Injection Pump
- 5 – Fuel Feed Pump
- 6 – To Fuel Tank

4JH4AE Engine Shown (4JH4-TE Engine and 4JH4-HTE Engine are similar)

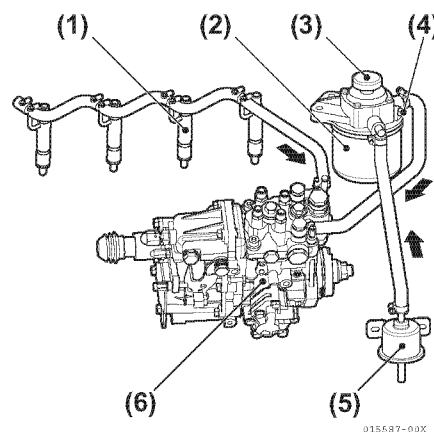

Figure 5-13

- 1 – Fuel Nozzle
- 2 – Fuel Return Line
- 3 – Fuel Filter
- 4 – Air Bleeding Bolt
- 5 – Electric Fuel Feed Pump
- 6 – Fuel Injection Pump

- 13. Remove the breather hose attached to the intake silencer.
- 14. Remove the intake silencer.

3JH4E and 4JH4AE Engines Shown

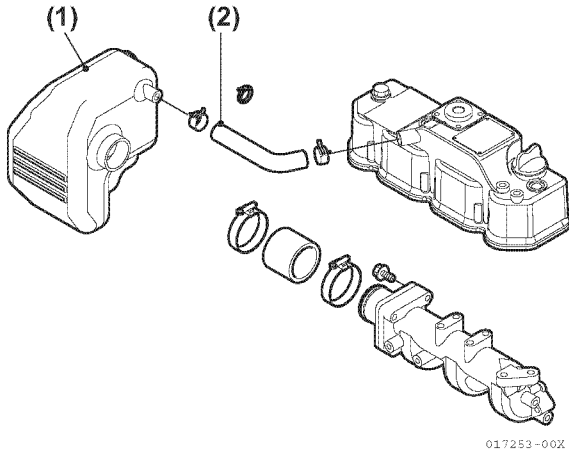

Figure 5-14

- 1 – Intake Silencer**
- 2 – Breather Hose**

4JH4-TE Engine Shown (4JH4-HTE Engine is similar)

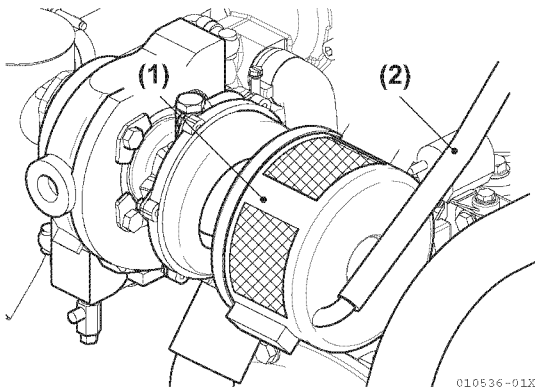

Figure 5-15

- 1 – Intake Silencer**
- 2 – Breather Hose**

15. Remove cooling system components from engine.

16. Remove the seawater hose connecting the heat exchanger and the mixing elbow.

17. Remove the mixing elbow from the exhaust manifold for 3JH4E and 4JH4AE (**Figure 5-16**) or from the turbocharger for 4JH4-TE and 4JH4-HTE (**Figure 5-17**).

3JH4E and 4JH4AE Engines Shown

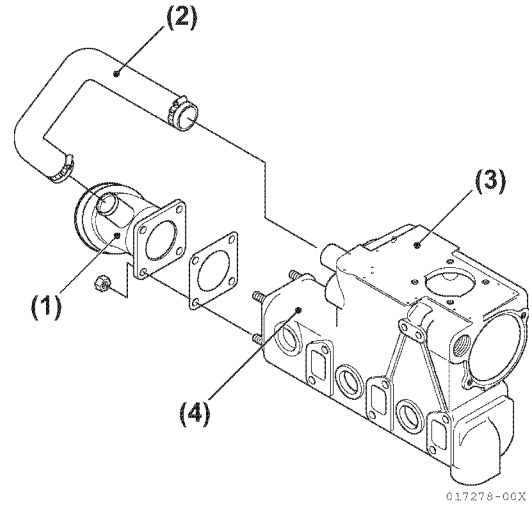

Figure 5-16

- 1 – Mixing Elbow**
- 2 – Rubber Hose**
- 3 – Heat Exchanger**
- 4 – Exhaust Manifold**

4JH4-TE and 4JH4HTE Engines Shown

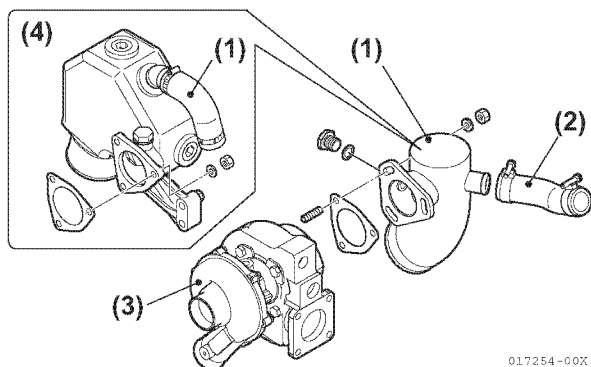

Figure 5-17

- 1 – Mixing Elbow
- 2 – Rubber Hose
- 3 – Turbocharger
- 4 – Option

18. Remove the turbocharger (only for 4JH4-TE and 4JH4-HTE):
- Remove the intake pipes (turbine, intercooler, intake manifold) (Figure 5-18) and (Figure 5-19).

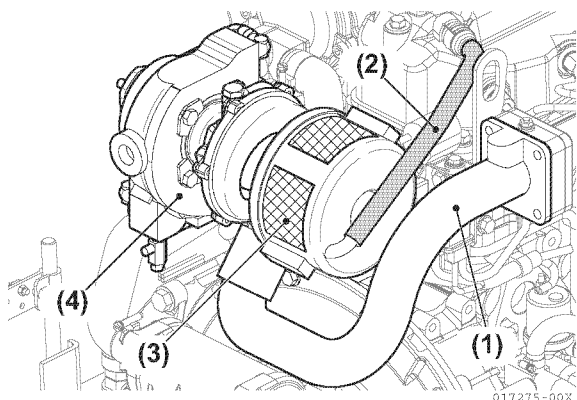

Figure 5-18

- 1 – Intake Pipe
- 2 – Rubber Hose for Breather
- 3 – Intake Silencer
- 4 – Turbocharger

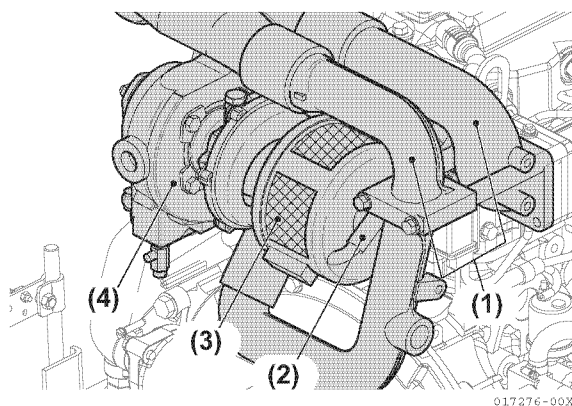

Figure 5-19

- 1 – Intake Pipe
- 2 – Rubber Hose for Breather
- 3 – Intake Silencer
- 4 – Turbocharger

- Remove the lubricating oil line from the turbine.
- Remove the oil return line from turbine (Figure 5-20).

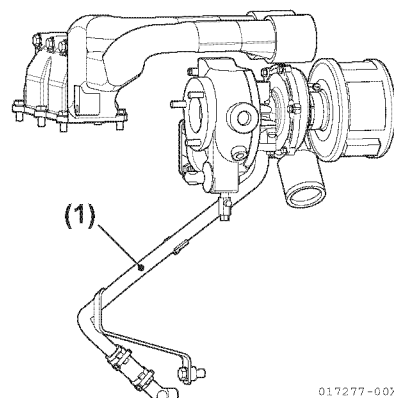
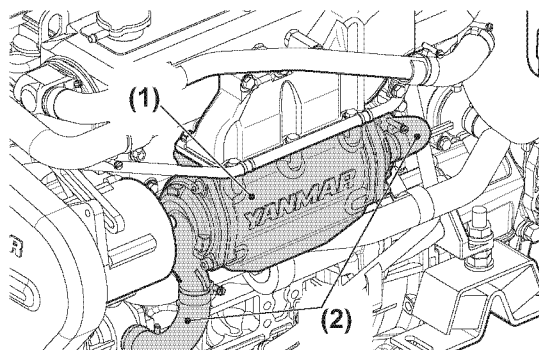

Figure 5-20

- 1 – Oil Return Line
- Remove the turbine.

19. Remove the intercooler (only for 4JH4-HTE) (Figure 5-21):

- Remove the seawater hoses (Heat exchanger, intercooler, lubricating oil cooler).
- Remove the intercooler.



017235-00X

Figure 5-21

- 1 – Intercooler
- 2 – Seawater Hose

20. Remove the coolant pipe (seawater / freshwater) (Figure 5-22) thru (Figure 5-25):

- Remove the seawater pipe (seawater pump, heat exchanger).
- Remove the freshwater pipe (freshwater pump, heat exchanger, exhaust manifold, freshwater pump).
- Remove the freshwater pipe (cylinder block, lubricating oil cooler, lubricating oil cooler, freshwater pump).

3JH4E and 4JH4AE Freshwater System

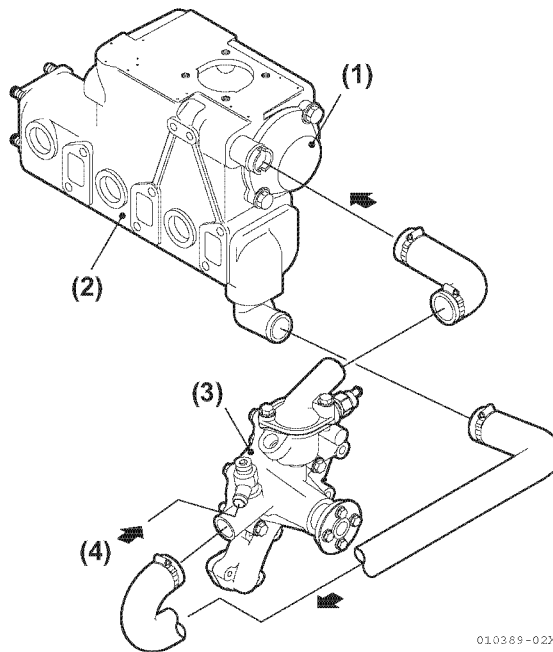

010389-02X

Figure 5-22

- 1 – Heat Exchanger
- 2 – Exhaust Manifold
- 3 – Freshwater Pump
- 4 – From Lubricating Oil Cooler

3JH4E and 4JH4AE Seawater System

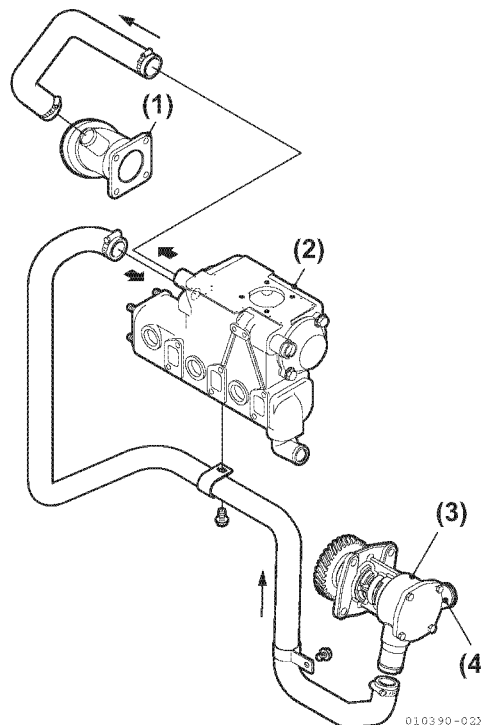

010390-02X

Figure 5-23

- 1 – Mixing Elbow
- 2 – Heat Exchanger
- 3 – Seawater Pump
- 4 – Seawater Inlet

4JH4-TE and 4JH4-HTE Freshwater System

4JH4-TE and 4JH4-HTE Seawater System

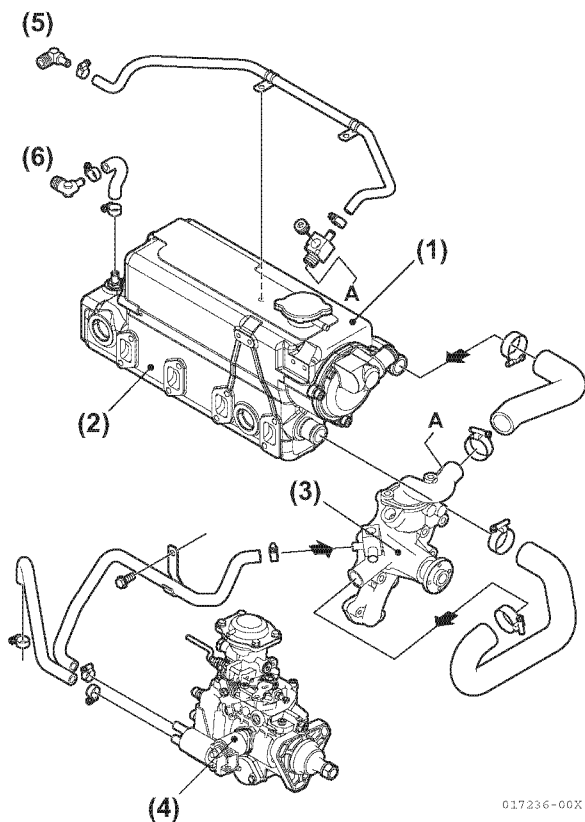

017236-00X

Figure 5-24

- 1 – Heat Exchanger
- 2 – Exhaust Manifold
- 3 – Freshwater Pump
- 4 – Fuel Injection Pump
- 5 – Turbocharger Freshwater Inlet
- 6 – Turbocharger Freshwater Outlet

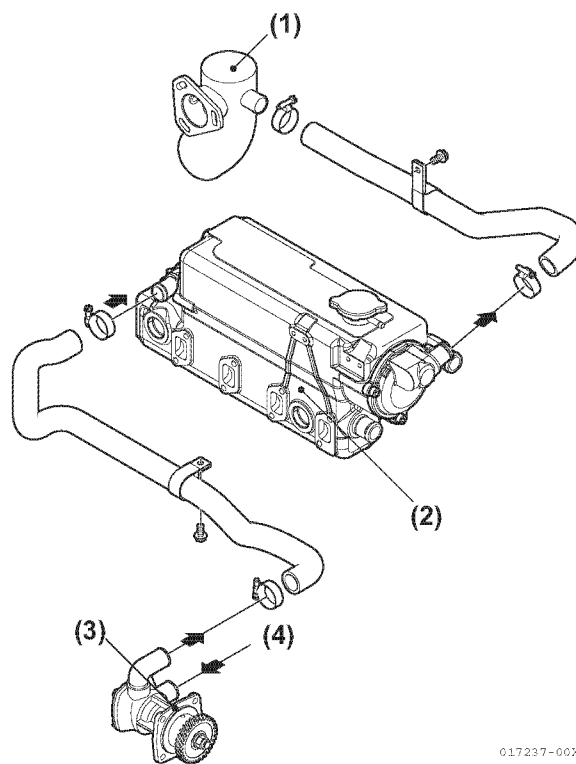

017237-00X

Figure 5-25

- 1 – Mixing Elbow
- 2 – Heat Exchanger
- 3 – Seawater Pump
- 4 – Seawater Inlet

21. Remove the heat exchanger and gasket packing (Figure 5-25).

22. Remove the seawater pump from the gear case (Figure 5-26) and (Figure 5-27).

3JH4E and 4JH4AE Engines

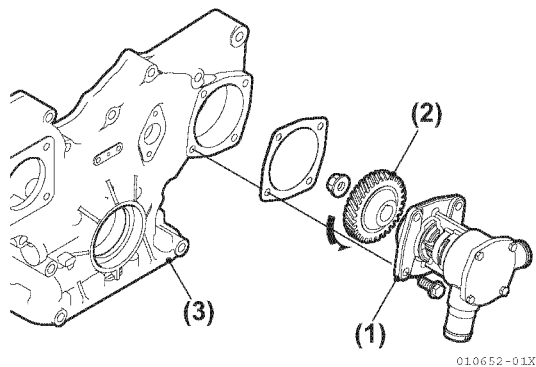

Figure 5-26

- 1 – Seawater Pump
- 2 – Pump Drive Gear
- 3 – Gear Case

4JH4-TE and 4JH4-HTE Engines

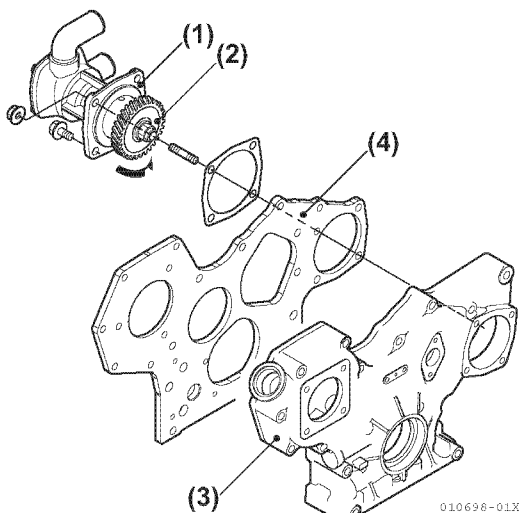

Figure 5-27

- 1 – Seawater Pump
- 2 – Pump Drive Gear
- 3 – Gear Case Cover
- 4 – Gear Case

23. Remove the lubricating oil filter (Figure 5-28).

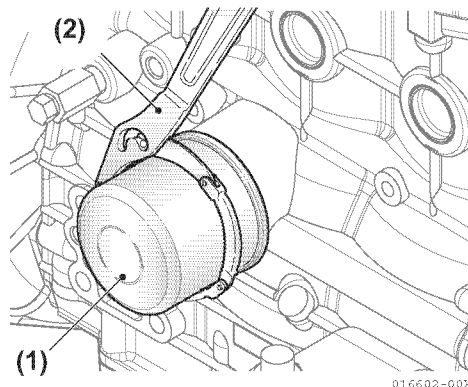

Figure 5-28

- 1 – Lubricating Oil Filter
- 2 – Filter Wrench

24. The lubricating oil cooler is located between the lubricating oil filter and the oil filter bracket, which is mounted on the cylinder block. The lubricating oil is cooled by freshwater (Figure 5-29):

- Remove the freshwater pipe (cylinder block, lubricating oil cooler, lubricating oil cooler outlet).
- Remove the lubricating oil filter from the lubricating oil cooler. *NOTICE: Do not use an adjustable wrench or other open-end tool as there is a risk of damaging the filter.*

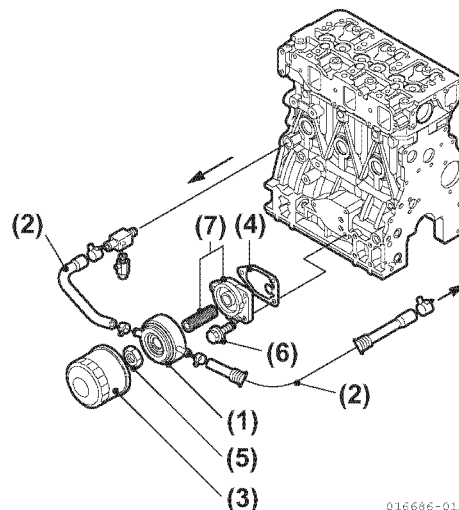

Figure 5-29

- 1 – Lubricating Oil Cooler
- 2 – Freshwater Pipes
- 3 – Lubricating Oil Filter
- 4 – Gasket
- 5 – Lubricating Oil Cooler Nut
- 6 – Bolt for Filter Bracket
- 7 – Filter Bracket

- Remove the lubricating oil cooler nut and lubricating oil cooler.
- Loosen the bolts for the filter bracket and remove the filter bracket.

25. Remove the lubricating oil dipstick and guide (Figure 5-30).

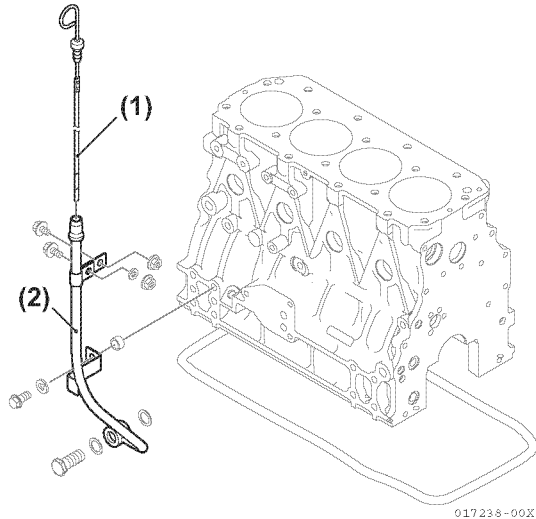

Figure 5-30

- 1 – Lubricating Oil Level Gauge
- 2 – Dipstick Guide

26. Drain engine oil into a suitable container.
NOTICE: ALWAYS be environmentally responsible.

- Remove the pipe coupling bolt, which holds the lubricating oil dipstick guide, and drain the lubricating oil from the engine.

Note: For easier draining, remove the oil filler cap (yellow) at the top of the rocker arm cover.

3JH4E and 4JH4AE:

If the oil filler cap is installed while draining the oil, the oil cap rubber diaphragm may be damaged due to a vacuum being created while draining.

- Remove the drain plug on the lower part of the case and drain the lubricating oil from the marine gearbox.

Note: When using a lubricating oil supply / discharge pump, place the intake hose in the dipstick guide for the engine or in the oil hole on top of the marine gear case.

3JH4E Engine Shown

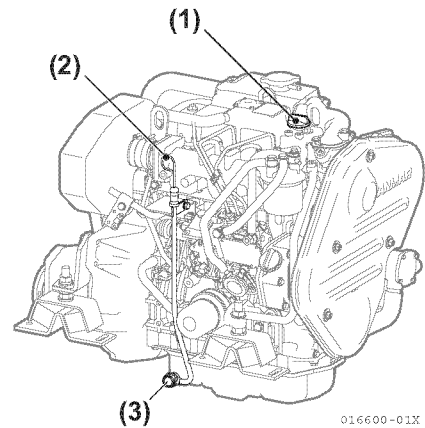

Figure 5-31

- 1 – Oil Filler Cap
- 2 – Lubricating Oil Dipstick
- 3 – Drain Plug

27. Remove the fuel injection line (Figure 5-32) thru (Figure 5-34):

- Remove the fuel injection line retainer.
- Loosen the cap nuts on both ends of the fuel injection line and remove the fuel injection line.
- Remove the fuel return line.

3JH4E Engine Shown

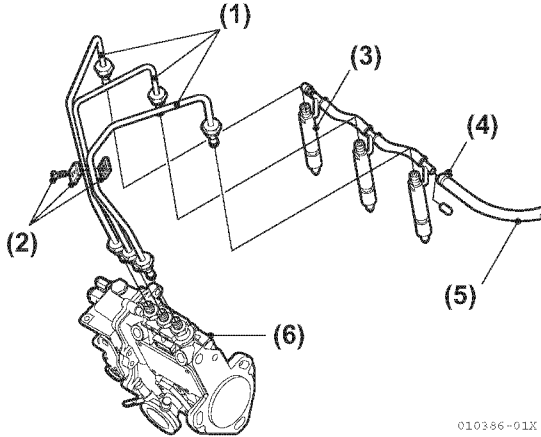

Figure 5-32

- 1 – Fuel Injection Line
- 2 – Fuel Injection Line Retainer
- 3 – Fuel Injection Nozzle
- 4 – Clamp
- 5 – Fuel Return Line
- 6 – Fuel Injection Pump

4JH4AE Engine Shown

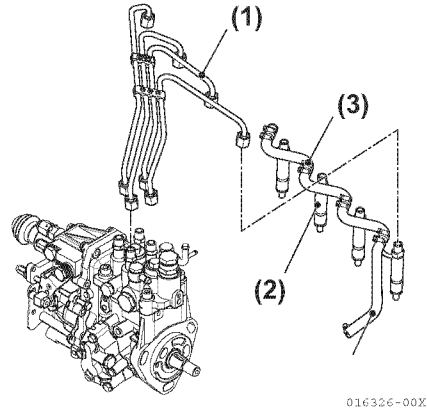

Figure 5-33

- 1 – Fuel Injection Line
- 2 – Fuel Injection Nozzle
- 3 – Fuel Return Line
- 4 – Fuel Injection Pump

4JH4-TE / 4JH4-HTE Engines Shown

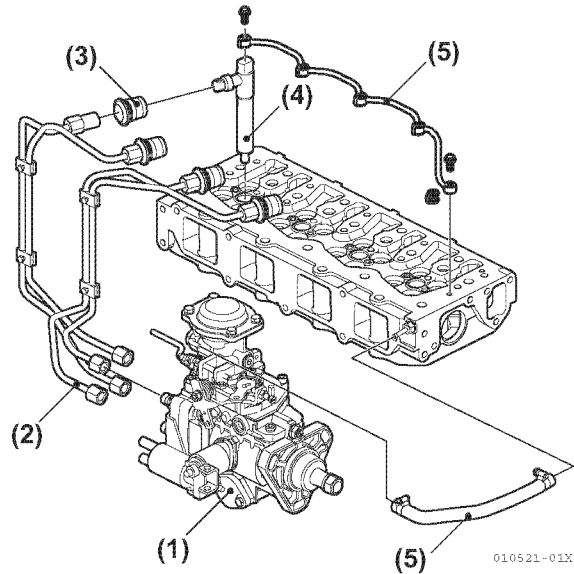

Figure 5-34

- 1 – Fuel Injection Pump
- 2 – Fuel Injection Line
- 3 – Line Seal
- 4 – Fuel Injection Nozzle
- 5 – Fuel Return Line

28. Remove the intake manifold and gasket
 29. Remove the freshwater pump and gasket from the cylinder head (**Figure 5-35**).

3JH4E Engine Shown

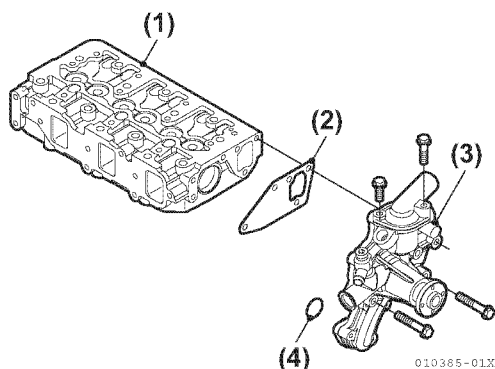

Figure 5-35

- 1 – Cylinder Head
- 2 – Gasket
- 3 – Freshwater Pump
- 4 – O-ring

30. Remove the fuel injection nozzles:
 3JH4E and 4JH4AE (2-valve head)
 Remove the bolt for the fuel nozzle retainer, and pull out the fuel nozzle retainer and fuel injection nozzle (**Figure 5-36**).

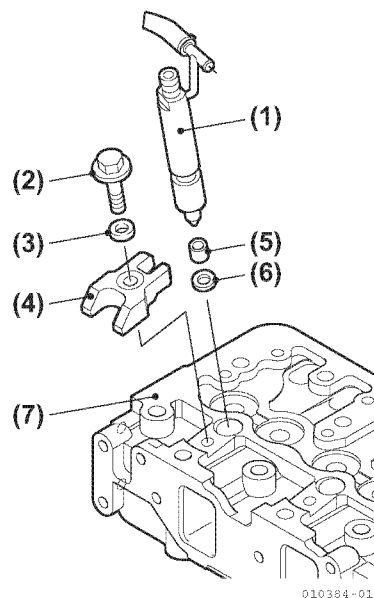

Figure 5-36

- 1 – Fuel Injection Nozzle
- 2 – Bolt
- 3 – Washer
- 4 – Fuel Nozzle Retainer
- 5 – Fuel Nozzle Protector
- 6 – Fuel Injection Seat
- 7 – Cylinder Head

Note: If the fuel nozzle protector stays in the cylinder head, make a note of the cylinder number and be sure to remove it when disassembling the cylinder head.

4JH4-TE and 4JH4-HTE (4-valve head)

- Remove the pipe seals from rocker arm cover. Insert a flat-bladed screwdriver into the slotted part of the rocker arm cover and remove it. Remove the rocker arm cover after removing the pipe seals (Figure 5-37).

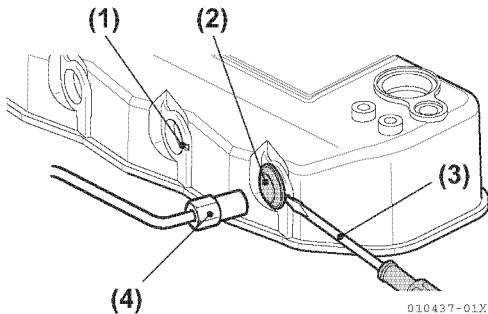

Figure 5-37

- 1 – Slit
- 2 – Line Seal
- 3 – Screwdriver
- 4 – Cap Nut of Fuel Injection Line

NOTICE: The fuel nozzles are held captive by the pipe seals. The pipe seals will be damaged if the rocker arm cover is removed with a pipe seal attached to the rocker arm cover.

- Loosen the bolts on the fuel injection nozzle retainers and extract the fuel injection nozzles (Figure 5-38).

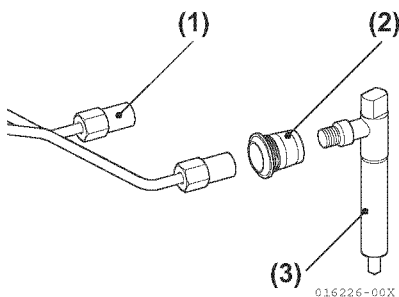

Figure 5-38

- 1 – Cap Nut of Fuel Injection Line
- 2 – Line Seal
- 3 – Fuel Injection Nozzle

Notes:

- If nozzle seat is left in the cylinder head, extract the nozzle seat after removing the cylinder head from cylinder block.
- When extracting a fuel injection nozzle, replace the used nozzle protector with a new one.

31. Remove the fuel injection pump:

- Loosen the nut on the fuel pump drive gear, and pull out the fuel pump drive gear with an extraction tool.

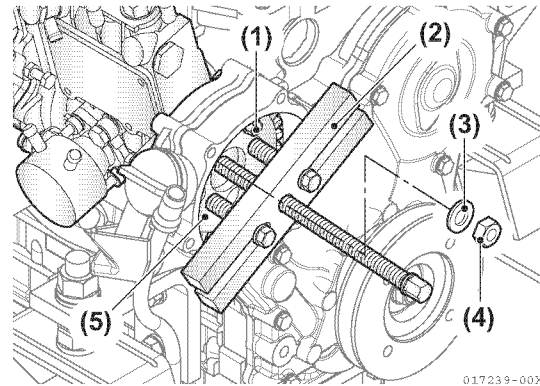

Figure 5-39

- 1 – Pump Flange Bolt
- 2 – Extraction Tool
- 3 – Spring Washer
- 4 – Pump Drive gear Nut
- 5 – Fuel Pump Drive Gear

- Remove the fuel injection pump and O-ring from the gear case flange (3JH4E and 4JH4AE).
- Remove the fuel injection pump and O-ring from the VE pump bracket, which is fixed to the gear case flange (4JH4-TE and 4JH4-HTE).

3JH4E Engine Shown

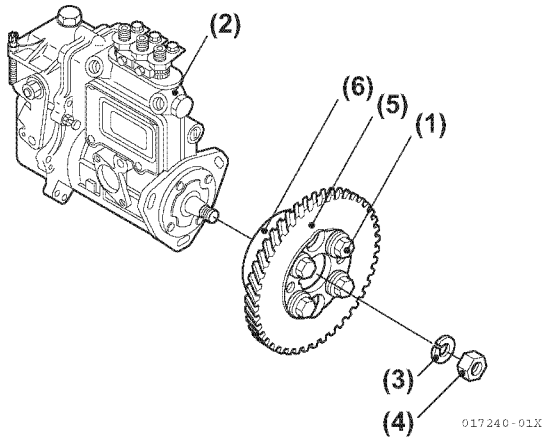

Figure 5-40

- 1 – Pump Flange Bolt
- 2 – Fuel Injection Pump
- 3 – Spring Washer
- 4 – Pump Drive Gear Nut
- 5 – Fuel Pump Drive Gear
- 6 – Fuel Pump Flange

NOTICE: Never disassemble pump drive gear and fuel pump flange.

32. Remove the rocker arm shaft assembly:

- Remove the rocker arm cover.
- Remove the bolts for the rocker arm shaft support, and remove the entire rocker arm shaft assembly.
- Pull out the push rods.

33. Remove the cylinder head:

- Loosen the cylinder head bolts with a torque wrench, and remove the cylinder head.

Note:

- Loosen the cylinder head bolts in two steps in the illustrated order (**Figure 5-41**) and (**Figure 5-42**).
- Place the cylinder head on cardboard to prevent the combustion surface from being damaged.
- Remove the cylinder head gasket.

3 cylinder head bolt disassembly order

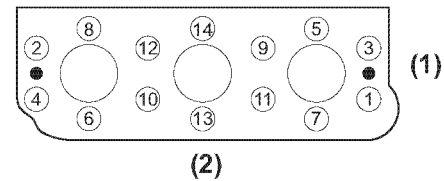

Figure 5-41

- 1 – Gear Case Side
- 2 – Fuel Injection Pump Side

4 cylinder head bolt disassembly order

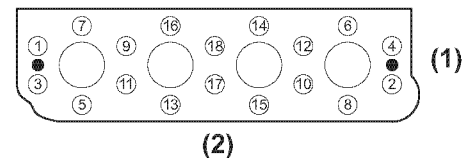

Figure 5-42

- 1 – Gear Case Side
- 2 – Fuel Injection Pump Side

34. Loosen the bolts for the clutch case flange, and remove the marine gear.

35. Loosen the flywheel bolts and remove the flywheel (**Figure 5-43**).

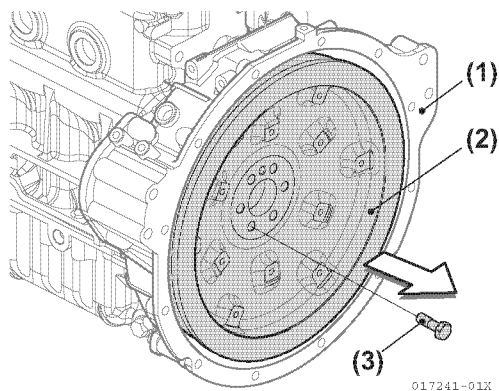

Figure 5-43

- 1 – Flywheel Housing
- 2 – Flywheel
- 3 – Flywheel Bolts

Note: Be careful not to scratch the ring gear. Loosen some of the bolts on the flywheel housing which attach to the oil pan spacer in preparation for the next disassembly step.

36. Turn the engine over:

- Place a wood block of appropriate size on the floor, and stand the engine on the flywheel housing (**Figure 5-44**).

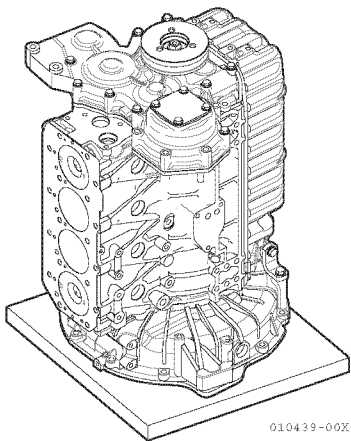

Figure 5-44

- Remove the engine mounting feet.

37. Loosen the nut holding the crankshaft V-pulley and remove the crankshaft V-pulley (**Figure 5-45**) with an extraction tool. When loosening the nut holding the V-pulley, be sure to use the correct tool to prevent rotation of the crankshaft.

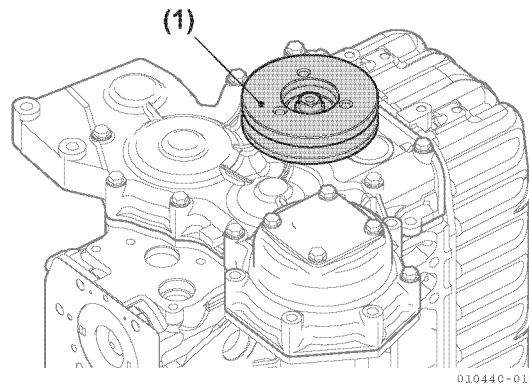

Figure 5-45

- 1 – Crankshaft V- pulley

38. Remove the oil pan and spacer (**Figure 5-46**).

Note: Some bolts of flywheel housing side should be loosened before removing the spacer.

3JH4E Engine Shown (4JH4AE Engine is similar)

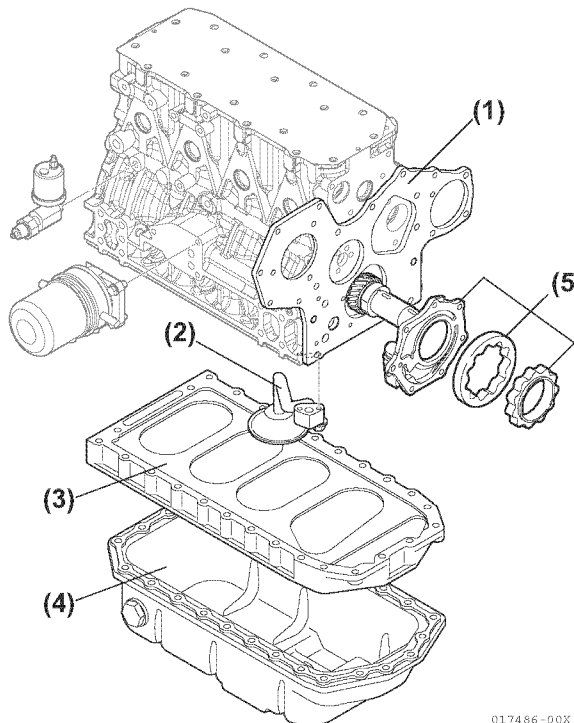

Figure 5-46

- 1 – Gear Case
- 2 – Lubricating Oil Inlet Line
- 3 – Oil Pan Spacer
- 4 – Oil Pan
- 5 – Oil Pump Assembly

- 39. Remove the lubricating oil inlet line and gasket (Figure 5-46).
- 40. Loosen the bolts, and remove the gear case cover from the gear case.
- 41. Remove the lubricating oil pump from the gear case flange (Figure 5-47).

4JH4-TE and 4JH4-HTE Engines Shown

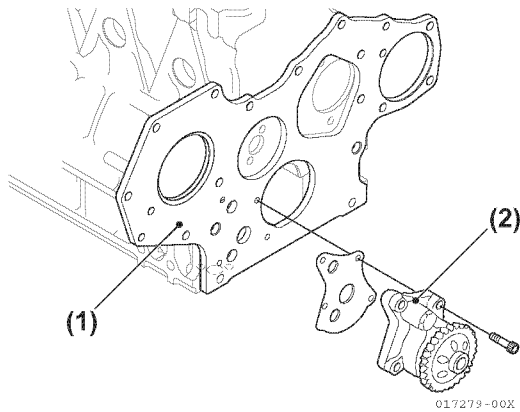

Figure 5-47

- 1 – Gear Case
- 2 – Lubricating Oil Pump

- 42. Loosen the three bolts holding the idle gear and pull out the idle gear and shaft (Figure 5-48).

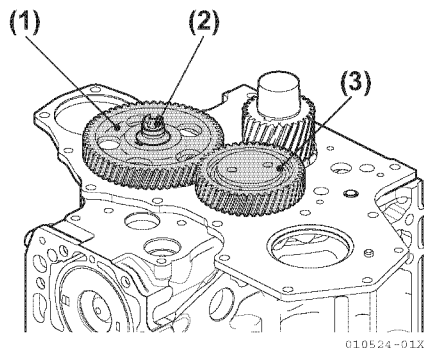

Figure 5-48

- 1 – Camshaft Gear
- 2 – Camshaft Assembly
- 3 – Idle Gear

- 43. Remove the camshaft (Figure 5-49):

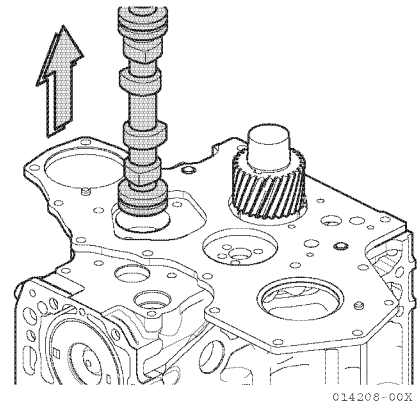

Figure 5-49

- Push up tappet by turning a camshaft to remove it from the cylinder block easily.
- Loosen the thrust metal bolts through the holes of the camshaft gear, and remove.
- Pull out the camshaft gear and camshaft assembly from the cylinder block.

Note: The camshaft gear and camshaft are shrink-fitted. They must be heated to 180-200 °C (356-392 °F) to disassemble.

- 44. Remove the pistons and connecting rods (Figure 5-50).

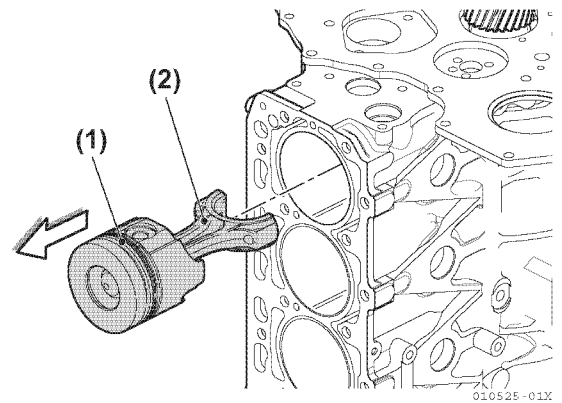

Figure 5-50

- 1 – Piston Connecting Rod
- 2 – Connecting Rod
- Loosen the rod bolts and remove the large end cap.

- Push the connecting rod and pull out the piston and connecting rod assembly.

45. Remove the gear case from the cylinder block (Figure 5-51).

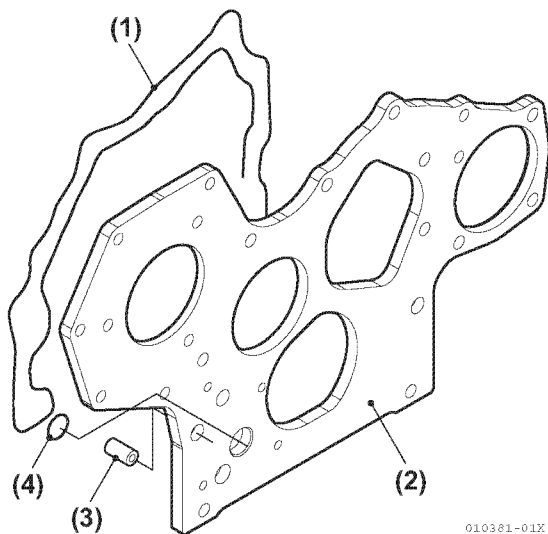

Figure 5-51

- 1 – Liquid Gasket
- 2 – Gear Case
- 3 – Knock Pin
- 4 – O-ring

46. Remove the O-rings from the lubricating oil passage (Figure 5-51).

Note:

- When mounting the gear case, match up the two knock pins for cylinder block.
- Coat the O-rings for the cylinder block lubricating oil passage with grease to maintain alignment when assembling.

47. Loosen but do not remove the main bearing bolts.

48. Turn the engine over, with the cylinder head mounting surface facing down (Figure 5-52).

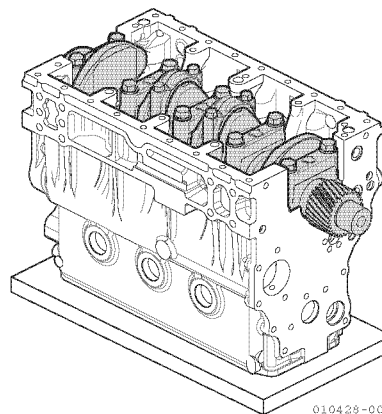

Figure 5-52

Note: Make sure that the cylinder head positioning pins on the cylinder block do not come in contact with the wood block.

49. Remove the flywheel housing and oil seal case from the cylinder block.

50. Remove the main bearing bolts (Figure 5-53).

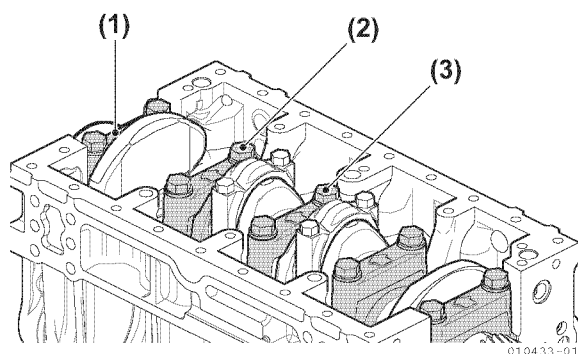

Figure 5-53

- 1 – Main Bearing Cap (Base)
- 2 – Main Bearing Cap
- 3 – Main Bearing Bolt

51. Remove the main bearing cap and lower main bearing (Figure 5-54).

Note: The thrust bearing (lower) is mounted to the main bearing cap base.

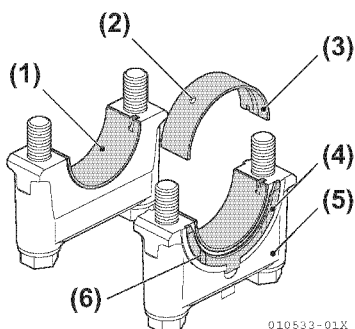

Figure 5-54

- 1 – Lower Main Bearing
- 2 – Oil Hole
- 3 – Upper Main Bearing
- 4 – Thrust Bearing
- 5 – Main Bearing Cap (Base)
- 6 – Groove

52. Remove the crankshaft (Figure 5-55).

Note:

- The thrust bearing (upper) is mounted to the standard main bearing.
- Remove the main bearing (upper) from the cylinder block.

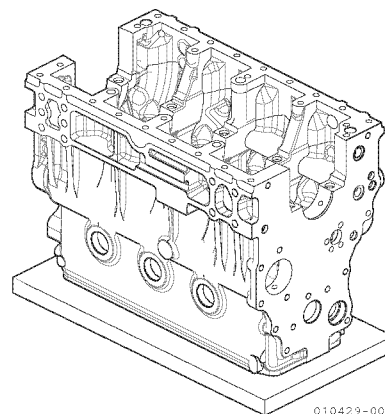
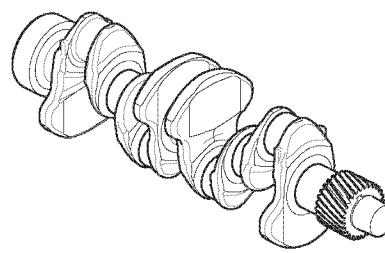

Figure 5-55

53. Remove the tappets from the tappet holes in the cylinder block (Figure 5-56).

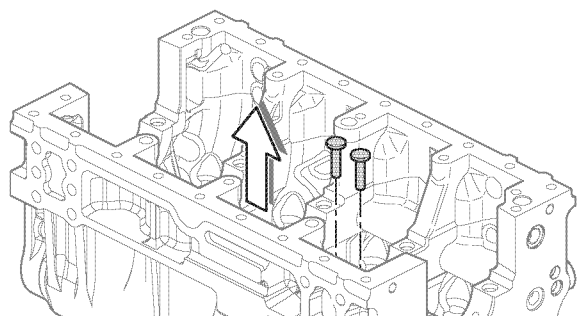

Figure 5-56

INSPECTION

Cylinder Block

The cylinder block is a light alloy casting machined with functionally designed ribs and support structures. The sidewalls are shaped to maximize rigidity, strength and quiet operation.

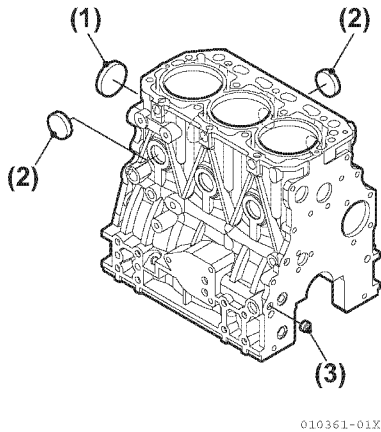

Figure 5-57

- 1 – Camshaft Hole Cap plug 50mm (1.97 in.)
- 2 – Cap Plug 30mm (1.18 in.)
- 3 – Main Gallery Cap Plug 12mm (0.47 in.)

Cylinder Block Inspection

Perform a visual inspection for cracks on engines that have been exposed to freezing temperatures, overturned or have otherwise been subjected to undue stress. Perform a dye penetrant inspection on any suspected cracks. Replace the cylinder block if a crack is not repairable.

Inspect Oil Passages and Cap Plugs

Clear all oil passages of any obstructions and ensure all cap plugs are secure.

Dye Penetrant Inspection Kit

	Quantity
Penetrant	1
Developer	2
Cleaner	3

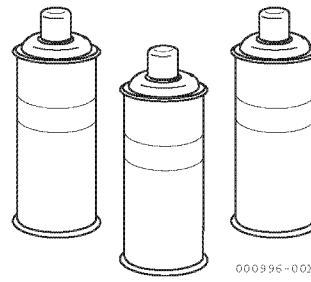

Figure 5-58

Dye Penetrant Inspection Procedure

The dye penetrant kit consists of an aerosol cleaner, penetrant and developer.

Note: Always read the instructions included with your dye penetrant kit before use.

1. Clean the area to be inspected.
2. Spray the cleaner directly on the surface to soften heavily soiled areas or wipe the area with a cloth moistened with cleaner.
3. When the surface is clean and dry, spray the penetrant on the suspect area so that it is completely covered and the penetrant liquid shows a smooth surface tension. Use enough penetrant to maintain a wet appearance for at least 10 to 15 seconds. Do not disturb for 5 to 10 minutes.
4. Spray the developer on a clean shop towel and remove any excess dye penetrant. Spray a uniform thin film of developer on the remaining penetrant and allow to develop for several minutes. Cracks will appear as red dots or a continuous red line on the surface being inspected.
5. When finished, clean the surface with the cleaner.

Replacement of Cup Plugs

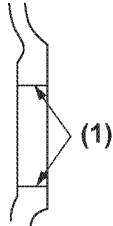
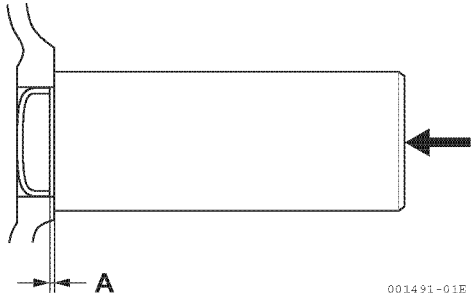
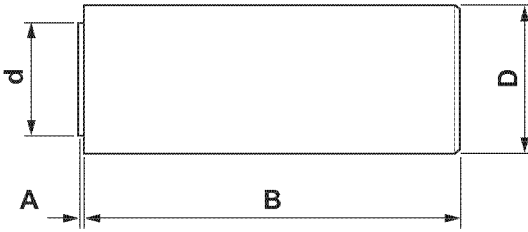
Step No.	Description	Procedure	Tool of Material Used																					
1	Clean and remove glue from the hole into which the cap plug is to be driven. (Remove scale and sealing material previously applied.)	 <p>001490-01X</p> <p>1 – Remove foreign materials with a screwdriver or saw blade.</p>	Screwdriver or saw blade Thinner																					
2	Remove grease from the cap plug.	Visually check the nick around the plug.	Thinner																					
3	Apply Three bond No. 4 to the seat surface where the plug is to be driven in.	Apply over the whole outside of the plug.	Three bond No. 4																					
4	Insert the plug into the hole.	Insert the plug so that it sits correctly.																						
5	Place a driving tool on the cap plug and drive it in using a hammer.	Drive in the plug parallel to the seating surface.	<ul style="list-style-type: none"> • Driving tool • Hammer 																					
 <p>001491-01E</p> <table border="1" data-bbox="472 1406 663 1487"> <tr> <td>A</td> </tr> <tr> <td>2-3 mm</td> </tr> </table> <p>*Using the special tool, drive the cup plug so that the edge of the plug is 2 mm (0.0787 in) below the cylinder surface.</p>		A	2-3 mm	 <p>001492-02X</p> <table border="1" data-bbox="1008 1361 1388 1442"> <tr> <td>A</td> <td>B</td> </tr> <tr> <td>3 mm</td> <td>100 mm</td> </tr> </table>	A	B	3 mm	100 mm	<table border="1" data-bbox="916 1532 1481 1733"> <thead> <tr> <th>Plug Dia.</th> <th>d</th> <th>D</th> </tr> </thead> <tbody> <tr> <td>12 mm</td> <td>11.9-12.0 mm</td> <td>20 mm</td> </tr> <tr> <td>25 mm</td> <td>24.9-25.0 mm</td> <td>35 mm</td> </tr> <tr> <td>30 mm</td> <td>29.9-30.0 mm</td> <td>40 mm</td> </tr> <tr> <td>45 mm</td> <td>44.9-45.0 mm</td> <td>55 mm</td> </tr> </tbody> </table>	Plug Dia.	d	D	12 mm	11.9-12.0 mm	20 mm	25 mm	24.9-25.0 mm	35 mm	30 mm	29.9-30.0 mm	40 mm	45 mm	44.9-45.0 mm	55 mm
A																								
2-3 mm																								
A	B																							
3 mm	100 mm																							
Plug Dia.	d	D																						
12 mm	11.9-12.0 mm	20 mm																						
25 mm	24.9-25.0 mm	35 mm																						
30 mm	29.9-30.0 mm	40 mm																						
45 mm	44.9-45.0 mm	55 mm																						

Cylinder Bore Measurements

Clean the mating surface of the cylinder head, the cylinder bores and all oil passages. Check the following items after removing any carbon deposits and / or gasket material residue.

- Check for any discoloration or cracks. If a crack is suspected, perform a dye penetrant inspection. Clean and clear all oil passages.

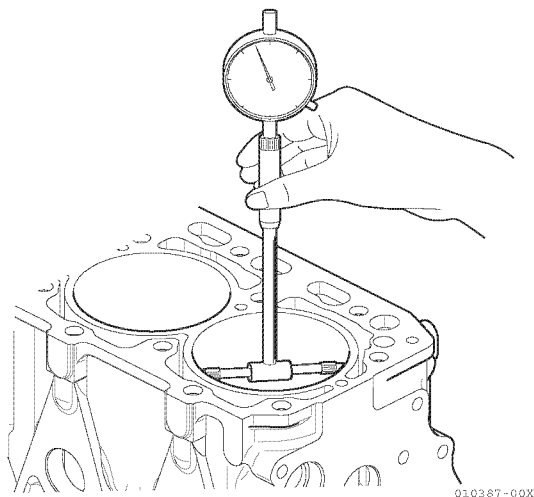

Figure 5-59

- Measure cylinder bore dimensions and compare measurements with allowable limits. Inspect cylinder bore(s) for physical damage and out-of-round conditions.
- Measure at 20 mm (0.8 in.) below the top of the cylinder bore (a).
- Measure at the center of piston travel (b).
- Measure at 20 mm (0.8 in.) from the bottom of the skirt in both directions A and B as shown in **Figure 5-60**.

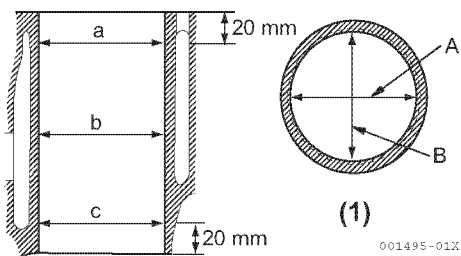

Figure 5-60

1 – Measure at 90° angles (A and B) at depths a, b and c.

Measuring Cylinder Bore For Out-Of-Round:

Use a Dial Bore Gauge to measure the cylinder bore diameters. Measure the cylinder bore twice at right angles at position A and B, shown in **(Figure 5-60)**.

- First two measurements, at position **(Figure 5-60, (a))** at the top of the cylinder bore.
- Second two measurements, at position **(Figure 5-60, (b))** in the middle of the cylinder bore.
- Third two measurements, at position **(Figure 5-60, (c))** at the bottom of the piston ring travel in the cylinder bore.

This produces six different measurement values. Calculate the average value of all these measurements for each cylinder bore and compare with the Out-Of-Round specifications listed below.

Measuring Cylinder Bore Diameters:

Measure the cylinder bore diameters as described above and compare values with wear limits stated below.

Item	Standard	Limit	
Cylinder bore diameter	3JH4 4JH4AE	88.0 - 88.030 mm	88.200 mm
	4JH4-TE 4JH4-HTE	84.0 - 84.030 mm	84.200 mm
Cylinder Out-Of-Round	0.01 mm or less	0.03 mm	

Cylinder Head

The cylinder head can be designed with 3 or 4 cylinder bores. Valve seats are treated with a special stellite alloy for superior resistance to heat and wear. The intake / exhaust valves are cooled with internal circulating water.

General Guidelines

CAUTION! *Identify all parts and their location using an appropriate method. It is important that all parts are returned to the same position during the reassembly process.*

Note: Record all measurements taken during disassembly and inspection.

3JH4E and 4JH4AE Engines Shown

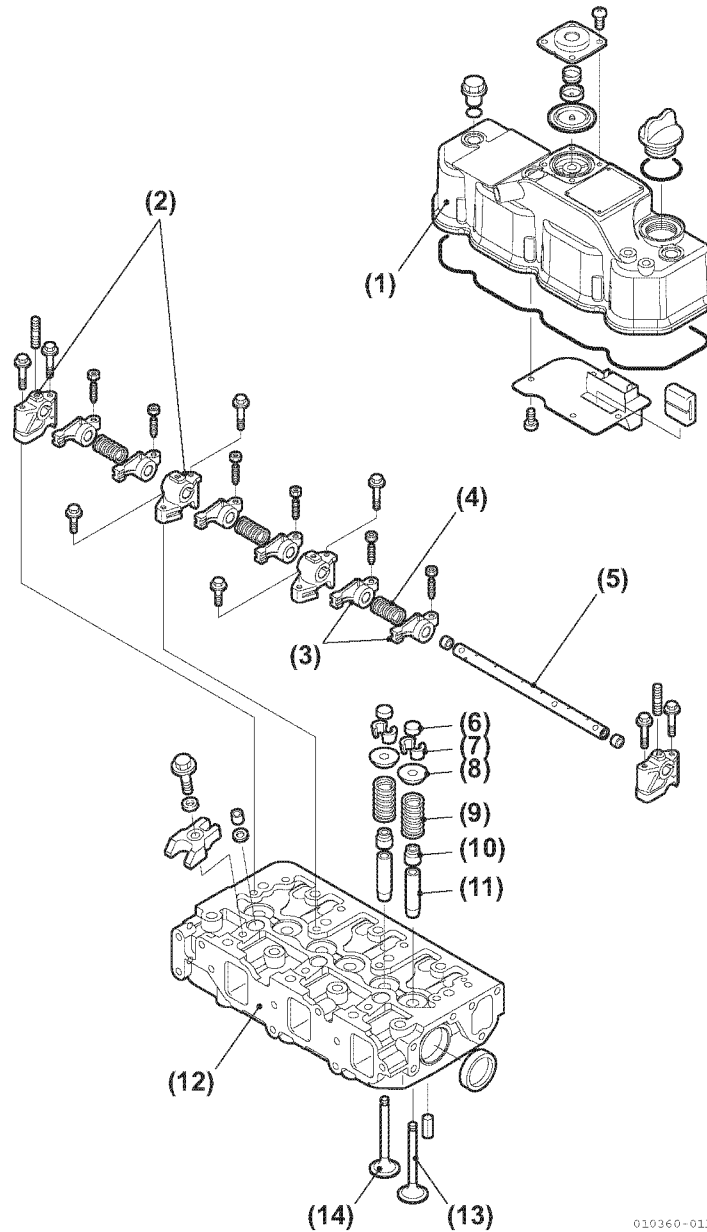

010360-01X

Figure 5-61

- | | |
|-------------------------------|---------------------|
| 1 – Rocker Arm Cover | 8 – Spring Retainer |
| 2 – Rocker Arm Support | 9 – Valve Spring |
| 3 – Rocker Arm | 10 – Stem Seal |
| 4 – Rocker Arm Spring(2Valve) | 11 – Valve Guide |
| 5 – Rocker Arm Shaft | 12 – Cylinder Head |
| 6 – Valve Cap(2Valve) | 13 – Intake Valve |
| 7 – Cotter | 14 – Exhaust Valve |

4JH4-TE and 4JH4-HTE Engines Shown

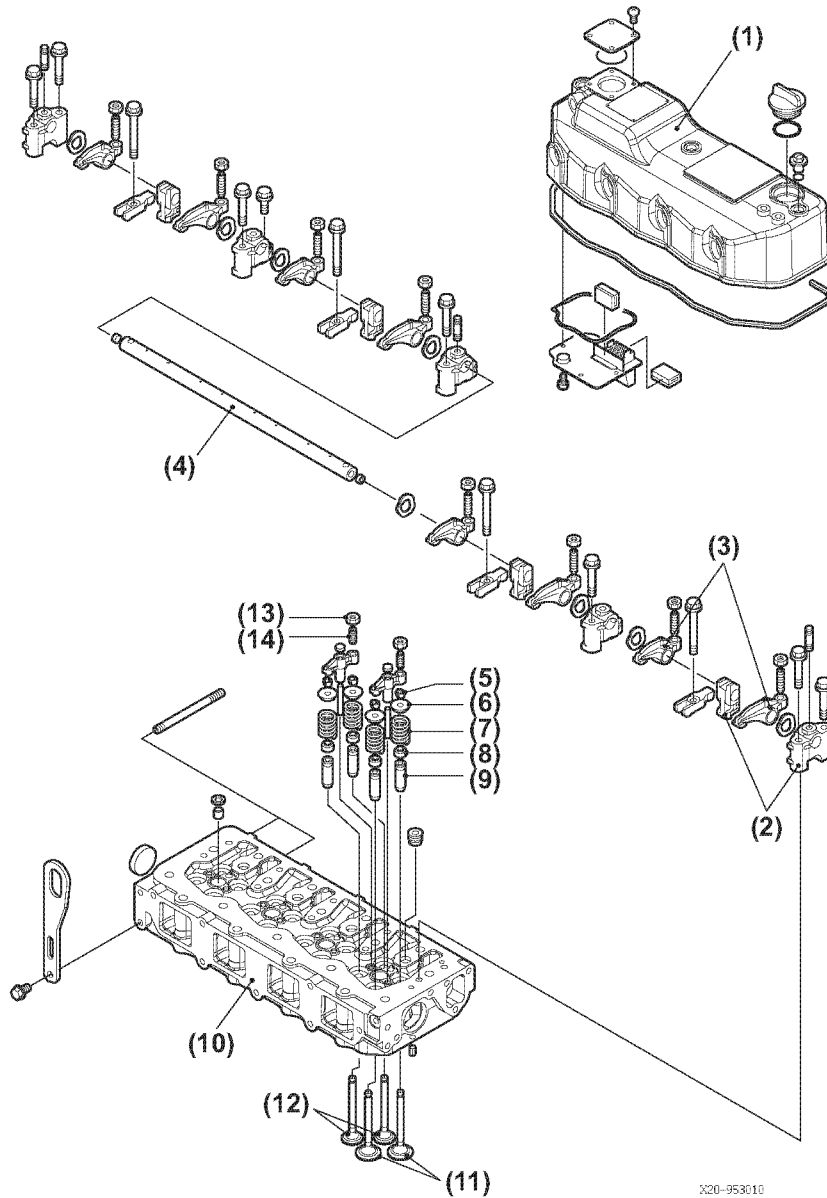

320-953010

Figure 5-62

- | | |
|------------------------|------------------------------|
| 1 – Rocker Arm Cover | 8 – Stem Seal |
| 2 – Rocker Arm Support | 9 – Valve Guide |
| 3 – Rocker Arm | 10 – Cylinder Head |
| 4 – Rocker Arm Shaft | 11 – Intake Valve |
| 5 – Cotter | 12 – Exhaust Valve |
| 6 – Spring Retainer | 13 – Adjusting Bolt (4Valve) |
| 7 – Valve Spring | 14 – Valve Bridge (4Valve) |

Cylinder Head Inspection

Clean all gasket material, sealant, and carbon from components. Use a suitable solvent and a soft-bristle brush to clean parts.

Visually inspect parts. Replace any parts that are obviously discolored, heavily pitted or otherwise damaged. Discard any part that does not meet its specified limit. **WARNING! Always read and follow safety related precautions found on containers of hazardous substances like parts cleaners, primers, sealants and sealant removers.**

NOTICE: Mark all valve train components so they can be installed in their original locations.

Note: Record all measurements taken during inspection.

The cylinder head is subjected to very severe operating conditions with repeated high-pressure, high temperature and cooling. Thoroughly remove all the carbon and dirt after disassembly and carefully inspect all parts.

Distortion of the combustion surface:

Carefully check for cylinder head distortion as this leads to gasket damage and compression leaks.

- Clean the cylinder head surface
- Place a straight-edge along each of the four sides and each diagonal. Measure the clearance between the straight- edge and combustion surface with a feeler gauge (Figure 5-63).

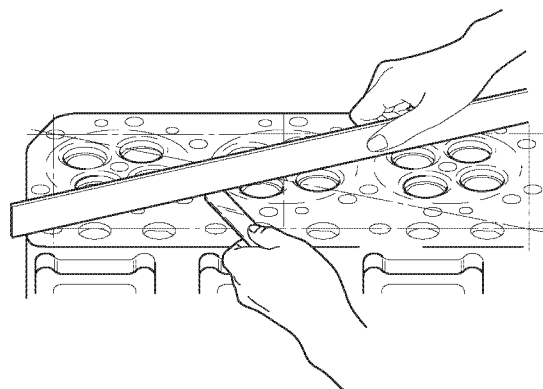

007087-00X

Figure 5-63

	Standard	Wear Limit
Cylinder Head Distortion	0.05 or less mm (0.002 or less in.)	0.15 mm (0.0059 in.)

- Check for cracks in the combustion surface. Remove the fuel injection nozzle, intake / exhaust valve and clean the combustion surface. Check for discoloration or distortion and conduct a dye penetrant inspection to check for any cracks (Figure 5-64).

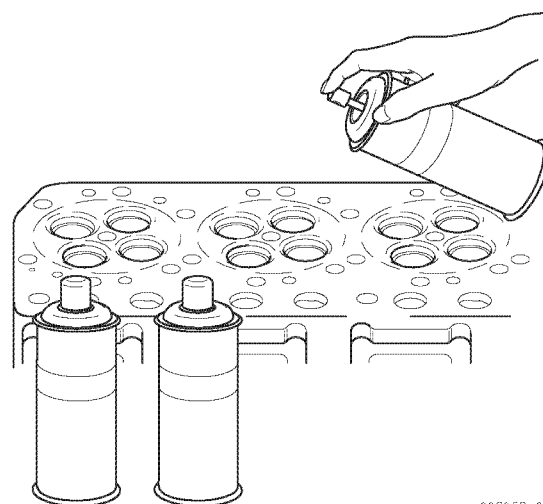

007357-00X

Figure 5-64

- Check the intake / exhaust valve seats. Check the surface and width of the valve seats. If they are too wide, or if the surfaces are rough, correct to the following standards (**Figure 5-65**):

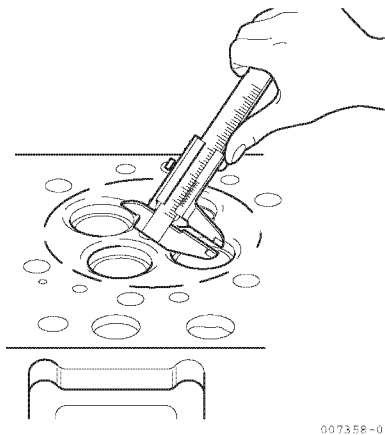

Figure 5-65

Seat Angle	Intake	120°
	Exhaust	90°

		Standard	Limit
Seat Width	Intake	1.07~1.24 mm (0.042~0.049 in.)	1.74 mm (0.069 in.)
	Exhaust	1.24~1.45 mm (0.049~0.057 in.)	1.94 mm (0.076 in.)

Valve Seat Correction Procedure

The most common method for correcting unevenness of the seat surface with a seat grinder is as follows:

- Use a seat grinder to make the surface even. As the valve seat width will be enlarged, first use a 70° grinder, then grind the seat to the standard dimension with a 15° grinder (**Figure 5-66**) and (**Figure 5-67**).

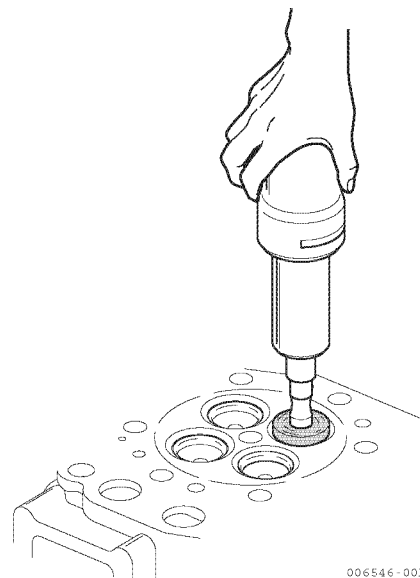

Figure 5-66

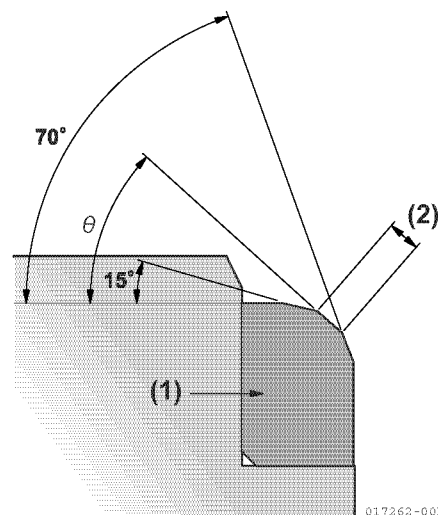

Figure 5-67

- 1 – Valve Seat
- 2 – Seat Width

Note: When valve seat adjustment is necessary, be sure to check the valve and valve guide. If the clearance exceeds the tolerance, replace the valve or the valve guide, and then grind the seat.

- Knead valve compound with oil and finish the valve seat with a lapping tool.
- Final finishing should be done with oil only.
- Use a rubber cap type lapping tool for cylinders without a lapping tool groove with oil only (Figure 5-68).



Figure 5-68

Note: Clean the valve and cylinder head with light oil or the equivalent after valve seat finishing is completed and make sure that there are no grindings remaining.

Insert adjusting shims between the valve spring and cylinder head when seats have been refinishing with a seat grinder.

Measure valve distortion after valve seat refinishing has been completed, and replace the valve and valve seat if it exceeds the tolerance. **CAUTION!** Any part which is found defective as a result of inspection or any part whose measured value does not satisfy the standard or limit must be replaced.

Inspection of Intake / Exhaust Valves and Valve Guides

Wearing and corrosion of valve stem

- Replace the valve stem is excessively worn or corroded (Figure 5-69) and (Figure 5-70).

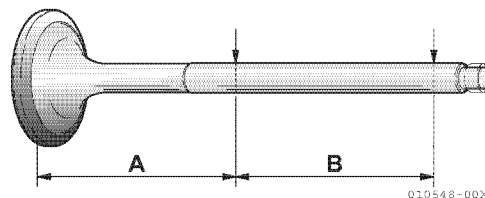

mm	
A	B
40	50

Figure 5-69

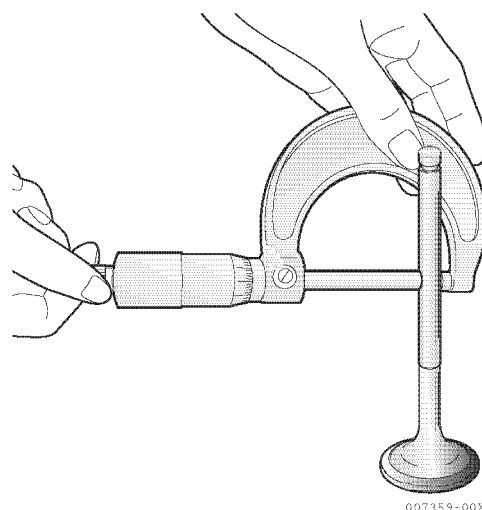

Figure 5-70

	Valve Stem Outside Dia.	Standard	Limit
3JH4E 4JH4AE	Intake	7.955~7.975 mm (0.3132~0.3140 in.)	7.90 mm (0.311 in.)
	Exhaust	7.955~7.970 mm (0.3132~0.3138 in.)	7.90 mm (0.311 in.)
4JH4-TE 4JH4-HTE	Intake	5.960~5.975 mm (0.2346~0.2352 in.)	5.90 mm (0.232 in.)
	Exhaust	5.945~5.960 mm (0.2341~0.2346 in.)	5.90 mm (0.232 in.)

- Inspection of valve seat wear and contact surface
Inspect for valve seat scratches and excessive wear. Check to make sure the contact surface is normal. The seat angle must be checked and adjusted if the valve seat contact surface is much smaller than the width of the valve seat.

Note: Keep in mind the fact that the intake and discharge valve have different diameters.

- Over long periods of use and repeated lapping, combustion efficiency may drop. Measure the sinking distance and replace the valve and valve seat if the valve sink exceeds the tolerance.

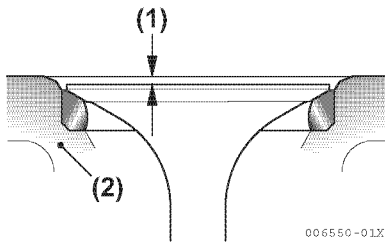

Figure 5-71

- 1 – Sink
- 2 – Cylinder Head

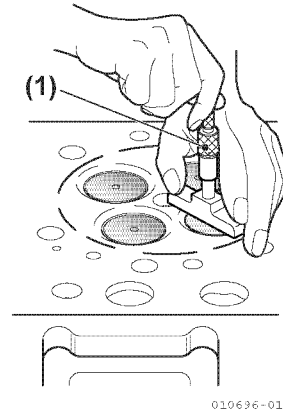

Figure 5-72

1 – Depth Micrometer

	Standard	Limit
Valve Sink	0.30-0.50	0.8

mm

- Measure inside diameter of valve guide.
Measure the inside diameter of the valve guide and replace it if it exceeds the wear limit.

		Standard		Limit
3JH4E 4JH4AE	Valve Guide Inside Diameter	Intake	8.010-8.025	8.2
		Exhaust	8.015-8.030	8.2
	Clearance	Intake	0.035-0.070	0.18
		Exhaust	0.045-0.075	0.18
4JH4-TE 4JH4-HTE	Valve Guide Inside Diameter	Intake	6.000-6.015	6.1
		Exhaust	6.000-6.015	6.1
	Clearance	Intake	0.025-0.055	0.16
		Exhaust	0.040-0.070	0.18

mm

Note: The inside diameter standard dimensions assume a pressure fit.

Replace the Valve Guide

- Use a valve guide extraction tool and extract the valve guide from the cylinder head.
- Put liquid nitrogen or ether (or alcohol) with dry ice added in a container and put the valve guide for replacement in it for cooling. Then insert it in by a valve guide inserting tool and a mallet.
- **CAUTION! Do not touch the cooled valve guide with bare hands to avoid skin damage.**
- Check the inside diameter and finish to the standard inside diameter as required with a reamer (Figure 5-73) and (Figure 5-74).

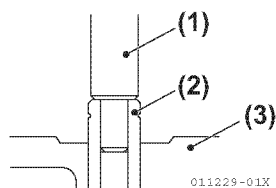

Figure 5-73

- 1 – Tool
- 2 – Valve Guide
- 3 – Cylinder Head

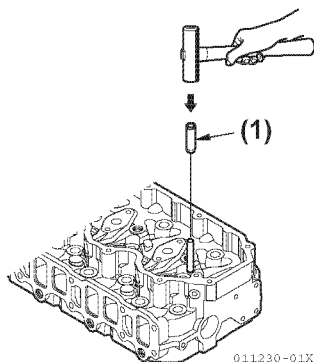

Figure 5-74

- 1 – Tool

Valve Guide Projection

Check the projection from the cylinder head (Figure 5-75).

Valve Guide Projection

3JH4E/ 4JH4AE	15.0 / -0.3 mm (0.591 / -0.012 in.)
4JH4-TE/ 4JH4-HTE	8.50 / -0.3 mm (0.335 / -0.012 in.)

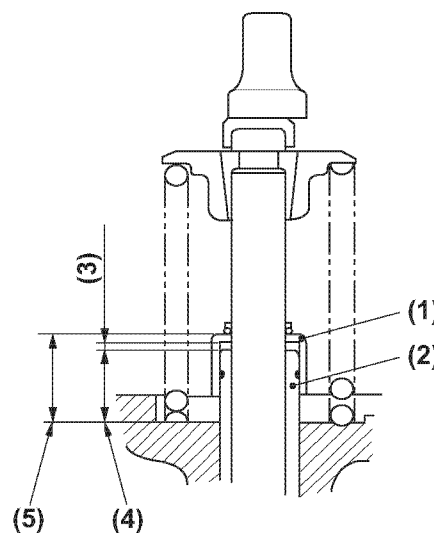

Figure 5-75

- 1 – Stem Seal
- 2 – Valve Guide
- 3 – Clearance
- 4 – Valve Guide Projection
- 5 – Stem Seal Projection

Valve Stem Seals

The valve stem seals on the intake/exhaust valve guides cannot be re-used once they are removed. Be sure to replace them.

Install the valve stem seal to the valve guide by using a tool.

The stem seal projection is as follows. The clearance between the stem seal and the upper surface of valve guide is around 0.2 mm to 0.8 mm (0.008-0.03 in.) (Figure 5-76).

Valve Stem Seal Projection

3JH4E/ 4JH4AE	190 / -0.3 mm (0.749 / -0.012 in.)
4JH4-TE/ 4JH4-HTE	10.2 0 / -0.3 mm (0.788 / -0.012 in.)

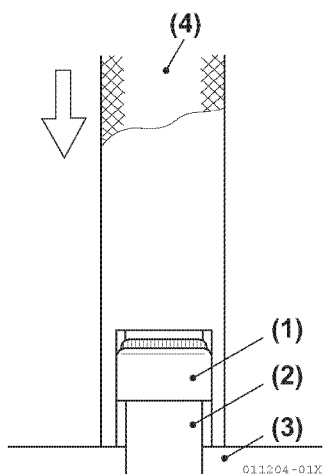

Figure 5-76

- 1 – Stem Seal
- 2 – Valve Guide
- 3 – Cylinder Head
- 4 – Valve Stem Seal Inserting Tool

The intake valve guide and exhaust valve guide are of different dimensions. The stem seal is marked by color for the distinction.

	Intake	Exhaust
3JH4E/ 4JH4AE	No mark	Yellow
4JH4-TE/ 4JH4-HTE	White	Black

When assemble the intake/exhaust valves, apply an adequate quantity of engine oil on the valve stem before inserting them.

Valve Springs

- Check the spring for scratches or corrosion.
- Measure the free length of the spring (Figure 5-77).

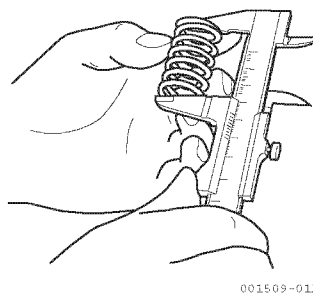

Figure 5-77

- Measure inclination (Figure 5-78) and (Figure 5-79).

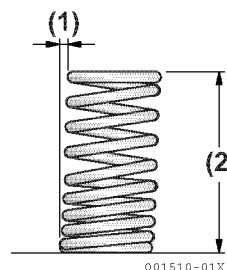

Figure 5-78

- 1 – Inclination
- 2 – Free Length

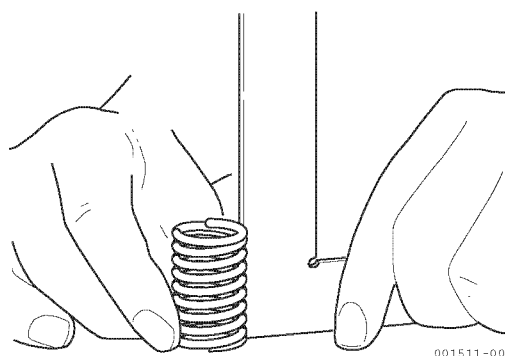

Figure 5-79

- Measure spring tension.

Valve Spring	3JH4E/4JH4AE		4JH4-TE/4JH4-HTE	
	Standard	Limit	Standard	Limit
Free Length A	44.4 mm (1.75 in.)	43.0 mm (1.69 in.)	37.4 mm (1.47 in.)	36.9 mm (1.45 in.)
Inclination B	-	1.1 mm (0.043 in.)	-	1.0 mm (0.039 in.)

- Assemble valve springs. The side with the smaller pitch (painted yellow) should face down (cylinder head).

Note: The pitch of the valve spring is not even. The side with the smaller pitch (yellow) should face down (cylinder head) when assembled (**Figure 5-80**).

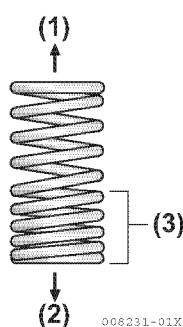

Figure 5-80

- 1 – Up Side
- 2 – Down Side
- 3 – Small Pitch Side (Yellow)

- Inspect the inside face of the spring retainer, the outside surface of the spring cotter, the contact area of the spring cotter inside surface and the notch in the head of the valve stem. Replace the spring retainer and spring cotter when the contact area is less than 70%, or when the spring cotter has been recessed because of wear.

Cylinder Head Assembly

Partially tighten the bolts in the specified order and then tighten to the specified torque, being careful that the head does not get distorted.

- Clean out the cylinder head bolt holes.
- Check for foreign matter on the cylinder head surface where it comes in contact with the block.
- Coat the head bolt threads and nut seats with lubricating oil.
- Use the positioning pins to line up the head gasket with the cylinder block.
- Match up the cylinder head with the head gasket and mount.

Figure 5-81 shows assembly head bolt tightening order for 3 Cylinder head of 3JH4E and 4 Cylinder Head of 4JH4AE, 4JH4-TE and 4JH4-HTE.

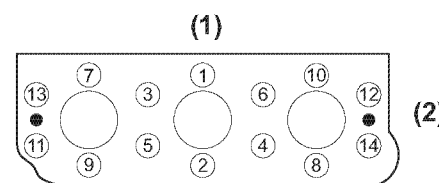

011231-01X

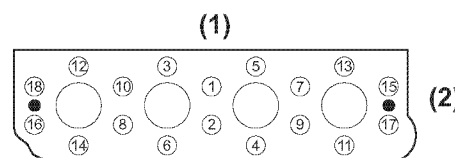

011232-01X

Figure 5-81

- 1 – Camshaft side
- 2 – Gear Case Side

	First	Second
Cylinder Head Bolt tightening Torque	44-54 N·m (32~40 lb-ft)	85.2-91.2 N·m (62.9~67.3 lb-ft)

Measure Top Clearance

- Place a high quality fuse (1.0mm diameter, 10mm long) in three positions on the flat part of the piston head.
- Assemble the cylinder head gasket and the cylinder head. Tighten the bolts in the specified order to the specified torque.
- Turn the crankshaft, in the direction of engine revolution, and press the fuse against the piston until it breaks.
- Remove the cylinder head. Remove the broken fuse.
- Measure the three positions where each fuse is broken and calculate the average (**Figure 5-82**).

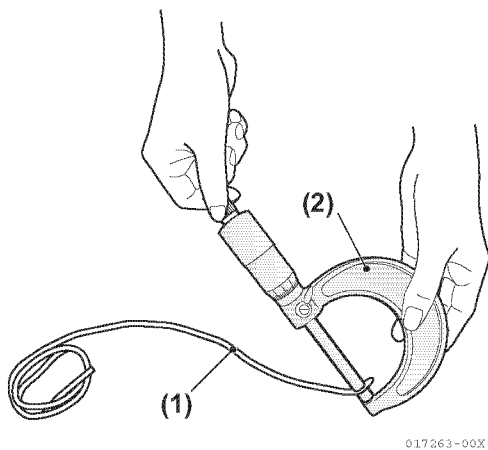

Figure 5-82

- 1 – Fuse Wire**
- 2 – Micrometer**

Top Clearance	0.68-0.80 mm (0.027-0.031 in.)
---------------	-----------------------------------

Intake / Exhaust Rocker Arms

The wear of rocker arm and rocker arm bushing may change opening/closing timing of the valve, and may in turn affect the engine performance according to the extent of the change.

Rocker arm shaft and rocker arm bushing:

Measure the outer diameter of the shaft and the inner-diameter of the vee-ring, and replace if wear exceeds the limit (**Figure 5-83**).

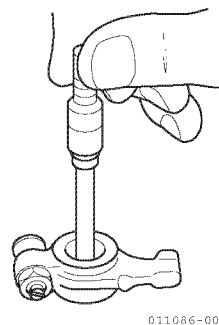

Figure 5-83

	Standard	Limit
Intake / Exhaust Rocker Arm Bushing Inside Dia.	16.000~16.020 mm (0.6299~0.6307 in.)	16.090 mm (0.6335 in.)
Outside Dia of Intake / Exhaust Rocker Arm Shaft.	15.966~15.984 mm (0.6286~0.6293 in.)	15.955 mm (0.6281 in.)
Rocker Arm Shaft and Bushing Clearance At Assembly	0.016~0.054 mm (0.0006~0.0021 in.)	0.140 mm (0.0055 in.)

Replace the rocker arm bushing if it moves and replace the entire rocker arm if there is no tightening clearance.

- Check the rocker arm spring and replace it if it is corroded or worn.
- Inspect the contact surface of the rocker arm and replace it if there is abnormal wear or flaking.

Valve Clearance Adjustment

- Make adjustments when the engine is cool.
See *Install the rocker arm shaft assembly and pushrods: on page 5-93.*

Intake / Exhaust Valve Clearance	0.15-0.25 mm (0.0059-0.0098 in.)
----------------------------------	-------------------------------------

- Check the valve timing. Be sure that the opening and closing angles for both the intake and the exhaust valves are checked when the timing gear is disassembled (The gauge on the flywheel can be read). All JH4 series engines use the same valve timing procedure (**Figure 5-84**).

Intake Valve Open	b.T.DC.	10°~20°
Intake Valve Closed	a.BDC.	40°~50°
Exhaust Valve Open	b.BDC.	51°~61°
Exhaust Valve Closed	a.TDC.	13°~23°

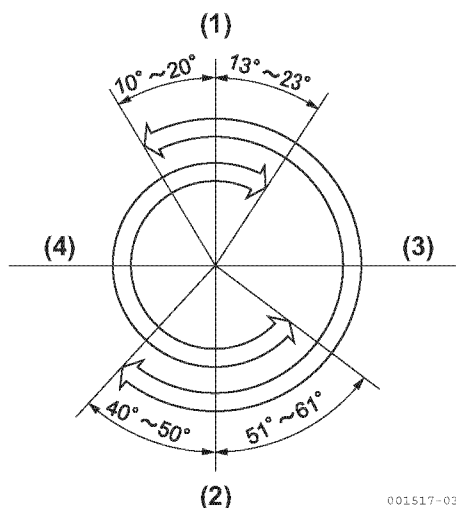

Figure 5-84

- 1 – Top Dead Center (TDC)
- 2 – Bottom Dead Center (BDC)
- 3 – Intake Valve Open Period 281°
- 4 – Exhaust Valve Open Period 254°

Piston and Piston Rings

Pistons are made of a special light alloy with superior thermal expansion characteristics. The back of the piston combustion chamber is oil-jet cooled.

The ID marks (model mark and size mark) are incised on the top surface of the piston (Figure 5-85).

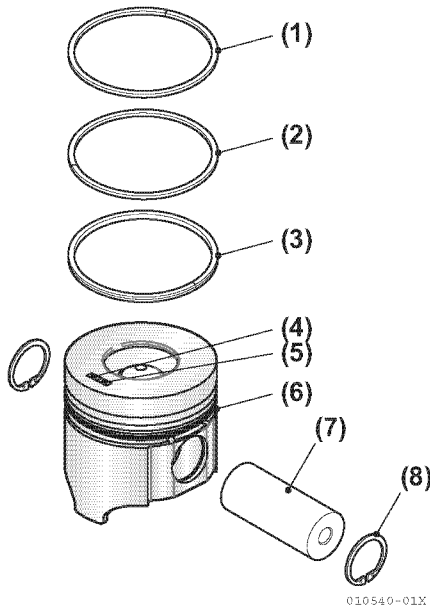

Figure 5-85

- 1 – 1st Compression Ring
- 2 – 2nd Compression Ring
- 3 – Oil Ring
- 4 – ID Mark (Size Mark)
- 5 – ID Mark (Model Mark)
- 6 – Piston
- 7 – Piston Pin
- 8 – Circlip

Model Mark

Model	Mark
3JH4E	V88
4JH4AE	4JH4
4JH4-TE	TE
4JH4-HTE	HTE

Size Mark

Size Mark
ML
MS

NOTICE: Piston shape differs among engine models. If any incorrect piston is installed, combustion performance will drop. Be sure to check the applicable engine model identification mark.

Piston

Piston head and combustion surface:

- Remove the carbon that has accumulated on the piston head and combustion surface, taking care not to scratch the piston. Check the combustion surface for any damage.
- Measurement of piston outside diameter/inspection
 - Replace the piston if the outsides of the piston or ring grooves are worn.
 - Measure the outside diameter in the position of 22 mm (0.86 in.) from the piston bottom in the direction vertical to the piston pin (Figure 5-86).

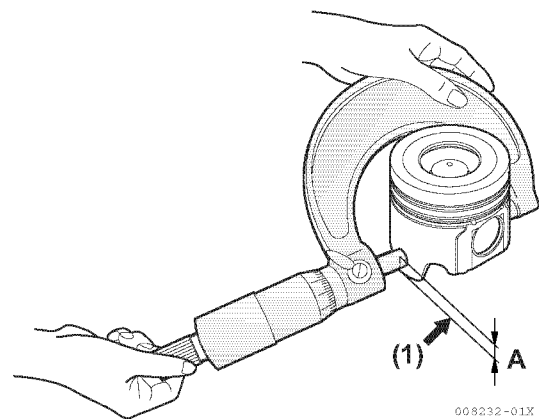

Figure 5-86

1 – Measurement Position

A = 22 mm

Piston Outside Diameter

Model	Standard	Limit	Clearance Between Piston and Cylinder
3JH4E	87.960-87.950 mm (3.4630-3.4626 in.)	87.900 mm (3.4606 in.)	0.045-0.075 mm (0.0018-0.0030 in.)
4JH4AE	87.945-87.935 mm (3.4624-3.4620 in.)	87.885 mm (3.4600 in.)	0.06-0.090 mm (0.0024-0.0036 in.)
4JH4-HT 4JH4-HTE	83.940-83.930 mm (3.3047-3.3043 in.)	83.340 mm (3.3023 in.)	0.065-0.095 mm (0.0026-0.0038 in.)

If the piston outside diameter exceeds the limit, replace the piston with new one.

Matching Cylinder and Piston

Piston must be matched with cylinder according to the below table. The size mark of a piston is shown on the top surface of the piston and the size mark of a cylinder block is shown on the non-operating side of the cylinder block. The service parts of pistons are provided.

	Tolerance	Size Mark	Piston Outside Diameter D2	
			Below+0.005 0 Minimum.	Below 0 -0.005 Minimum.
			ML	MS
Cylinder Inside Diameter D1	+0.030 maximum +0.020 minimum.	L	○	X
	Below +0.020 +0.010 minimum.	M	○	○
	Below +0.010 0 minimum.	S	X	○

Model	Cylinder inside diameter D1	Piston outside diameter D2
3JH4E	88 mm (3.465 in.)	87.955 mm (3.4630 in.)
4JH4AE		87.940 mm (3.4624 in.)
4JH4-TE 4JH4-HTE	84 mm (3.307 in.)	83.940 mm (3.3047 in.)

Piston Pin

A floating type piston pin is used in this engine. The piston pin can be pressed into the piston pin hole at room temperature (Coat with oil to make it slide easily).

Measure the outer diameter and replace the pin if it is excessively worn.

		Standard	Limit
Piston Pin Hole Inside Dia.	3JH4E / 4JH4AE	26.000 ~ 26.009 mm (1.0236 ~ 1.0240 in.)	26.020 mm (1.0244 in.)
	4JH4-TE / 4JH4-HTE	28.000 ~ 28.009 mm (1.1024 ~ 1.1028 in.)	28.020 mm (1.1032 in.)
Piston Pin Outside Dia.	3JH4E / 4JH4AE	25.995 ~ 26.000 mm (1.0234 ~ 1.0236 in.)	25.965 mm (1.0222 in.)
	4JH4-TE / 4JH4-HTE	27.995 ~ 28.000 mm (1.1022 ~ 1.1024 in.)	27.965 mm (1.1010 in.)
Clearance	JH4 SIRES	0 ~ 0.014 (0 ~ 0.0006 in.)	0.074 mm (0.0029 in.)

Measure the piston pin hole diameter at the positions a and b in directions A and B (Figure 5-87).

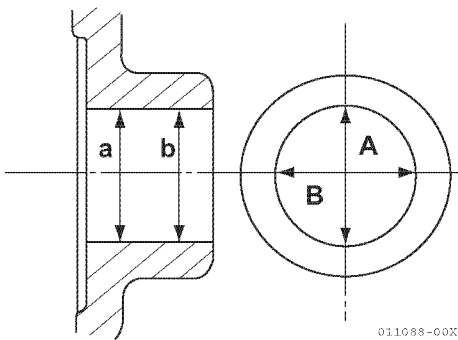

Figure 5-87

Measure the piston pin outside diameter at the positions a and b in directions A and B (Figure 5-88).

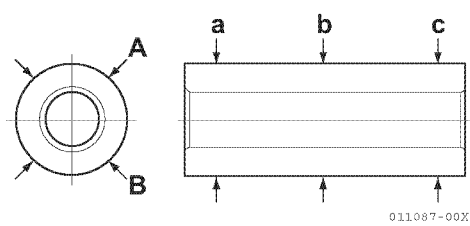

Figure 5-88

Piston Rings

There are 2 compression rings and 1 oil ring. The absence of an oil ring on the piston skirt prevents oil from being kept on the thrust surface and in turn provides good lubrication (**Figure 5-89**).

- Measure the thickness and width of the rings, and the ring-to-groove clearance after installation. Replace if wear exceeds the limit (**Figure 5-90**).

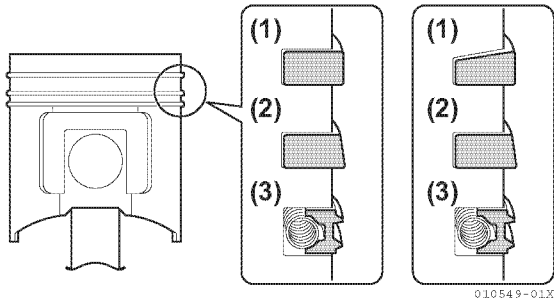

Figure 5-89

- 1 – 1st Compression Ring
- 2 – 2nd Compression Ring
- 3 – Oil Ring

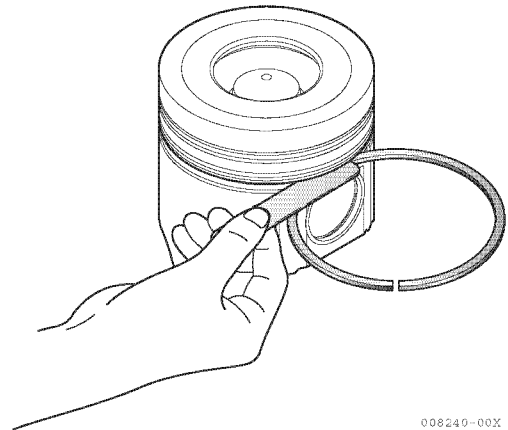

Figure 5-90

			Standard	Limit
3JH4E 4JH4AE	Top Ring	Groove Width	2.060 - 2.075 mm (0.0811 - 0.0817 in.)	2.170 mm (0.0854 in.)
		Ring Width	1.970 - 1.990 mm (0.3677 - 0.3685 in.)	1.950 mm (0.3669 in.)
		Clearance	0.070 - 0.105 mm (0.0028 - 0.0042 in.)	0.200 mm (0.0040 in.)
	Second Ring	Groove Width	2.025 - 2.040 mm (0.0797 - 0.0803 in.)	2.140 mm (0.0842 in.)
		Ring Width	1.970 - 1.990 mm (0.0776 - 0.0783 in.)	1.950 mm (0.0768 in.)
		Clearance	0.035 - 0.070 mm (0.0014 - 0.0028 in.)	0.190 mm (0.0075 in.)
	Oil Ring	Groove Width	4.015 - 4.030 mm (0.1587 - 0.1593 in.)	4.130 mm (0.1626 in.)
		Ring Width	3.970 - 3.990 mm (0.1563 - 0.1571 in.)	3.950 mm (0.1555 in.)
		Clearance	0.025 - 0.060 mm (0.0010 - 0.0024 in.)	0.180 mm (0.0071 in.)
4JH4-TE 4JH4-HTE	Top Ring	Groove Width	2.060 - 2.080 mm (0.0811 - 0.0819 in.)	2.180 mm (0.0858 in.)
		Ring Width	1.970 - 1.990 mm (0.3677 - 0.3685 in.)	1.950 mm (0.3669 in.)
		Clearance	(half-keystone)	-
	Second Ring	Groove Width	2.050 - 2.065 mm (0.0807 - 0.0813 in.)	2.170 mm (0.0854 in.)
		Ring Width	1.970 - 1.990 mm (0.0776 - 0.0783 in.)	1.950 mm (0.0768 in.)
		Clearance	0.060 - 0.095 mm (0.0024 - 0.0038 in.)	0.220 mm (0.0087 in.)
	Oil Ring	Groove Width	4.020 - 4.035 mm (0.1583 - 0.1589 in.)	4.120 mm (0.1622 in.)
		Ring Width	3.970 - 3.990 mm (0.1563 - 0.1571 in.)	3.950 mm (0.1555 in.)
		Clearance	0.030 - 0.066 mm (0.0012 - 0.0026 in.)	0.180 mm (0.0071 in.)

- Push the piston ring into a cylinder and measure the piston ring gap with a feeler gauge. Push the ring to about 30mm (1.2 in.) from the bottom of the cylinder skirt (**Figure 5-91**).

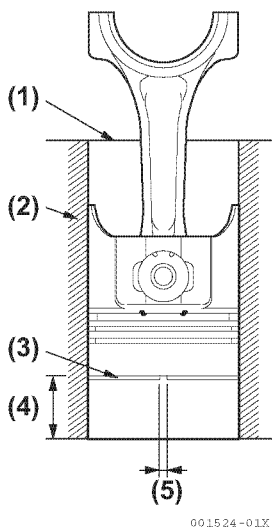

Figure 5-91

- 1 – Head Surface
- 2 – Cylinder Block
- 3 – Piston Ring
- 4 – Approximate 30mm
- 5 – Gap

JH4 Series	Standard	Limit
Top Ring End Gap	0.200-0.400 mm (0.0079-0.0079 in.)	0.490 mm (0.193 in.)
Second Ring End Gap	0.200-0.400 mm (0.0079-0.0079 in.)	0.490 mm (0.193 in.)
Oil Ring End Gap	0.200-0.400 mm (0.0079-0.0079 in.)	0.490 mm (0.193 in.)

- Remove the piston rings from the cylinder.
- Thoroughly clean the ring grooves in the piston.
- Install the rings with the manufacturer's mark facing up (**Figure 5-92**).

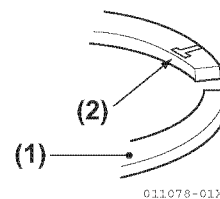

Figure 5-92

- 1 – Piston Ring
- 2 – Punched Manufacturer's Mark

- After installing the piston ring, make sure it moves easily and smoothly.
- Stagger the piston ring gaps at 120° intervals. See *Assemble the piston and connecting rod* on page 5-87.
- The oil ring includes a coil expander. The coil expander joint should be opposite (180°) the oil ring gap (**Figure 5-93**).

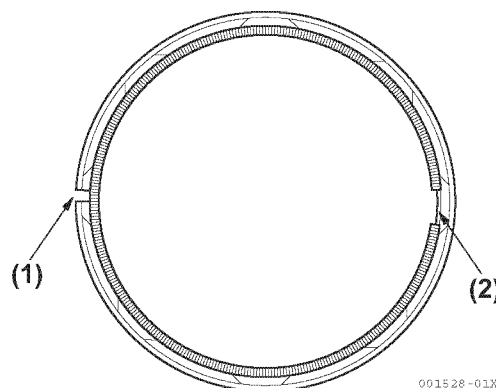

Figure 5-93

- 1 – Oil Ring Gap
- 2 – Joint of Coil Expander

Connecting Rod

The connecting rod is made of high-strength forged carbon steel. The large crankshaft bearing is equipped with a bearing cap and a 2-piece aluminum bearing insert assembly. The piston pin bearing is a non-serviceable copper alloy bushing that is factory-installed. (Figure 5-94).

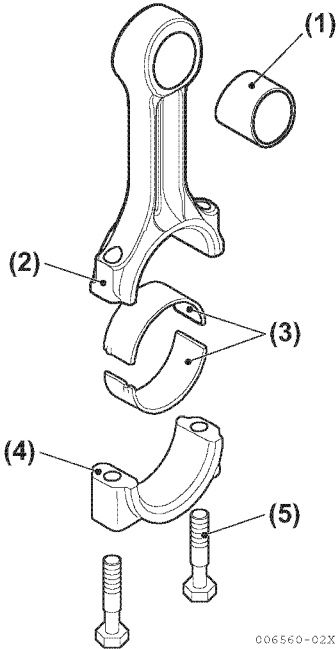

Figure 5-94

- 1 – Piston Pin Bearing
- 2 – Connecting Rod
- 3 – Crank Pin Bearing
- 4 – Connecting Rod Cap
- 5 – Connecting Rod Cap Bolts

Connecting Rod Bearing Alignment Inspection

Ensure the connecting rod is not twisted.

- Insert the appropriate mandrel into both ends of the connecting rod (Figure 5-95).
- Measure alignment.
- Replace connecting rod if it exceeds the specifications shown (Figure 5-95).

	Standard	Limit
Connecting Rod Twist and Alignment	Less than 0.03 mm (at 100 mm) (Less than 0.0012 in. (at 3.937 in.))	0.08 mm (0.0031 in.)

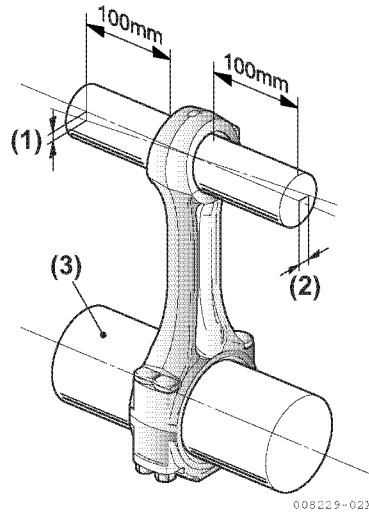

Figure 5-95

- 1 – Alignment
- 2 – Twist
- 3 – Mandrel

Figure 5-96 shows twist measurement using a connecting rod alignment tool.

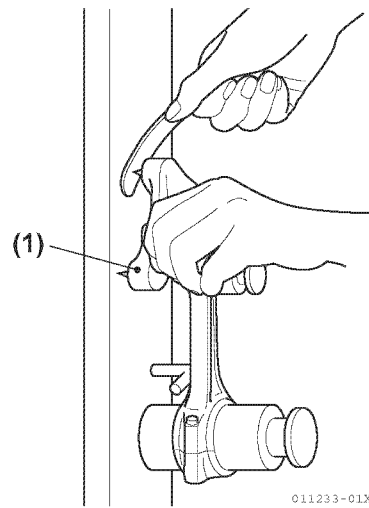

Figure 5-96

- 1 – Connecting Rod Alignment Tool

Check connecting rod side clearance.

- Install the connecting rod to the crankshaft.
- Check the side clearance as shown (Figure 5-97).

	Standard	Limit
Connecting rod side clearance	0.20 ~ 0.40 mm (0.008 ~ 0.016 in.)	0.55 mm (0.022 in.)

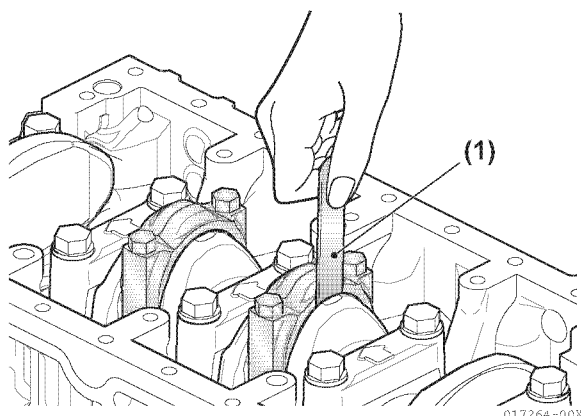

Figure 5-97

1 – Thickness Gauge

Inspecting Crank Pins

Inspect each crank pin surface for flaking, melting or discoloration and measure each crank pin for proper oil clearance.

- Measure the crankpin outside diameter.
- Measure the inside diameter of the connecting rod crankshaft bearing.
- Calculate the oil clearance by subtracting the measured values.

Replace the connecting rod if the oil clearance is greater than the allowable limit.

Correct the crankshaft by grinding to a uniform undersize standard dimension (if available).

Use an oversized bearing insert in the connecting rod, if available (Figure 5-98).

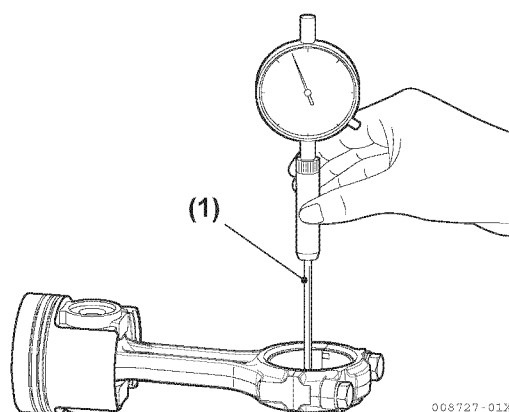

Figure 5-98

1 – Cylinder gauge

NOTICE: When installing the connecting rod to the crankshaft, match the alignment marks on the rod cap and tighten the rod cap bolts to standard torque.

Rod Bolt Torque	44.1-49.1 N·m (4.50~5.01 lb-ft)
-----------------	------------------------------------

Item	Standard	Limit
Rod Bearing ID	48.000 - 48.026 mm (1.890 - 1.891 in.)	-
Crankpin O.D.	47.952 - 47.962 mm (1.888 - 1.888 in.)	47.902 mm (1.886 in.)
Bearing Thickness	1.492 - 1.500 mm (0.05874 - 0.05906 in.)	-
Clearance	0.038 - 0.074 mm (0.0015 - 0.0029 in.)	0.150 mm (0.0061 in.)

An alternate procedure of measuring crank pin oil clearance is to use a plastic gauge.

- Lay the plastic gauge on the surface of the crank pin.
- Mount the connecting rod on the crank pin and tighten to specified torque.

- Remove the connecting rod and measure the plastic gauge with measuring paper (Figure 5-99).

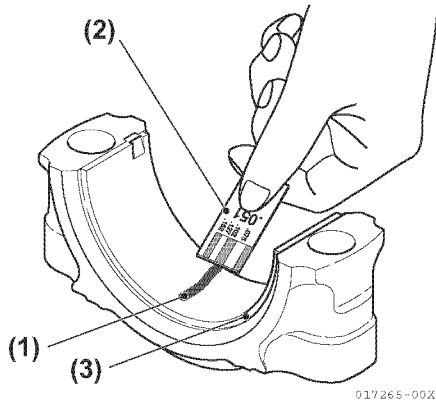

Figure 5-99

- 1 – Plastic Gauge
- 2 – Measuring Paper
- 3 – Connecting Rod Bearing Insert

Precautions for inspecting the crank pin clearances.

- Wash the crank pin surface thoroughly.
- Clean the crankshaft bearing of the connecting rod and install the crankshaft bearing inserts. Make sure the bearing inserts fit properly.
- When installing the connecting rod to the crankshaft, make sure to match the alignment marks on the rod cap (Figure 5-100).
- Coat the cap bolts with engine oil and tighten to the specified torque.
- If a torque wrench is not available, make match marks on the bolt heads and rod cap (to indicate the proper torque position) and retighten the bolts to those positions (Figure 5-101).

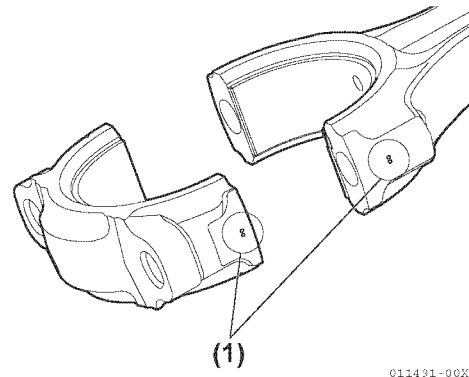

Figure 5-100

- 1 – Alignment Marks (Punched Mark)

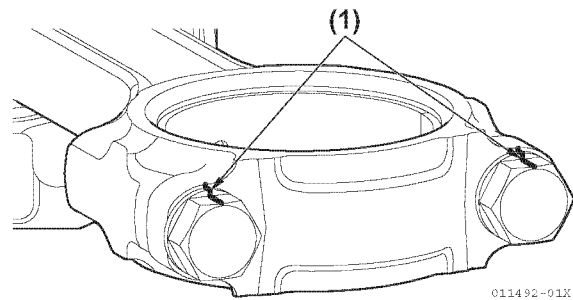

Figure 5-101

- 1 – Match Marks
- Be sure there is no sand, metal cuttings or other foreign matter in the oil.
 - Ensure the crankshaft is not scratched.
 - Clean and clear all oil holes.

Piston Pin Bushing

- Measure piston pin clearance. Excessive piston pin bearing wear may result in damage to the piston pin or the piston itself.
- Measure the piston pin bearing inside diameter and the piston pin outside diameter. Calculate the oil clearance from the difference of the measured values (**Figure 5-102**). See *Measure the outside diameter, roundness and taper at each crank pin and journal. Resurface the crankshaft pins and journals if measurements exceed specifications. on page 5-73.*

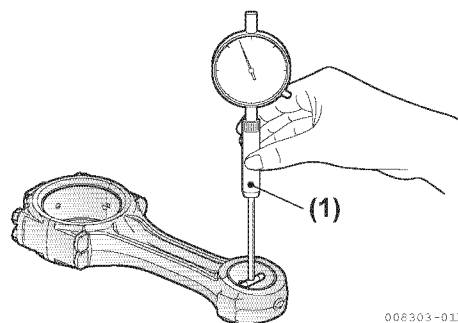

Figure 5-102

1 – Cylinder Gauge

	3JH4E and 4JH4AE		4JH4-TE and 4JH4-HTE	
	Standard	Limit	Standard	Limit
Piston Pin Bushing Inside Diameter	26.025 - 26.038 mm (1.0246 - 1.0251 in.)	26.068 mm (1.0263 in.)	28.025 - 28.038 mm (1.1033 - 1.1039 in.)	26.068 mm (1.0263 in.)
Oil Clearance	0.025 - 0.043 mm (0.00098 - 0.00169 in.)	0.101 mm (0.00398 in.)	0.025 - 0.043 mm (0.00098 - 0.00169 in.)	0.101 mm (0.00398 in.)

Note: The piston pin bearing is not available as a service item. It is factory-installed and is included in the connecting rod assembly.

Figure 5-103 shows the orientation of components when assembling connecting rods and pistons.

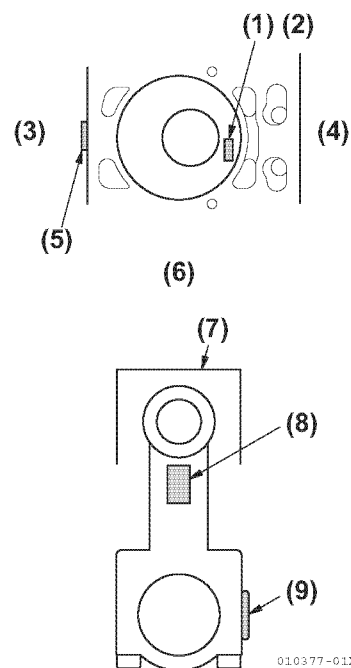

Figure 5-103

- 1 – Size Mark
- 2 – Model Mark
- 3 – Camshaft Side
- 4 – Nozzle Side
- 5 – Cylinder Size Mark
- 6 – Flywheel End
- 7 – Piston Mark
- 8 – Embossed Mark (Flywheel End)
- 9 – Match Mark

Crankshaft and Main Bearings

The crank pins and crank journals are induction hardened for superior durability. The crankshaft is designed with balance weights for minimum vibration.

The crankshaft main bearing journals are of the hanger type. The upper bearing insert (cylinder block side) is provided with an oil groove. There is no oil groove on the lower bearing insert (bearing cap side). The journal cap (location cap) on the flywheel end has a thrust bearing which supports the thrust loads (Figure 5-104) and (Figure 5-105).

3JH4E Crankshaft Shown

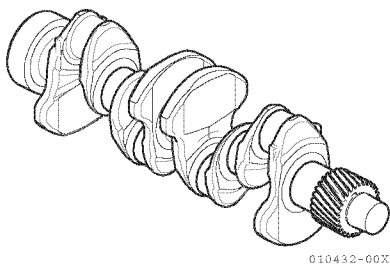

Figure 5-104

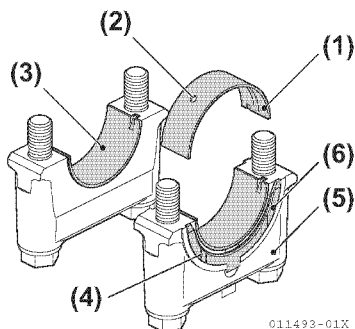

Figure 5-105

- 1 – Upper Main Bearing Insert
- 2 – Oil Hole
- 3 – Lower Main Bearing Insert
- 4 – Groove
- 5 – Main Bearing Cap (Base)
- 6 – Thrust Bearing

Crankshaft

- Perform a dye penetrant inspection after cleaning the crankshaft, and replace the crankshaft if there are any cracks or other significant damage (Figure 5-106).

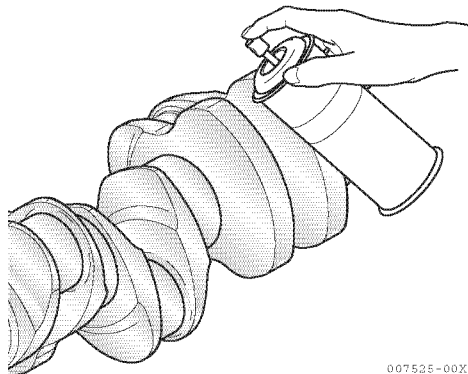

Figure 5-106

- Support the crankshaft with V-blocks at both ends of the journals. Measure the deflection of the center journal with a dial gauge while rotating the crankshaft to check for crankshaft run-out (Figure 5-107).

Crankshaft Run-out Limit (1/2 The Dial Gauge Reading)	0.02 mm (0.0008 in.)
--	-------------------------

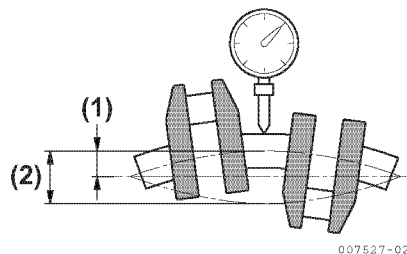

Figure 5-107

- 1 – Bend
- 2 – Deflection

- Measure the outside diameter, roundness and taper at each crank pin and journal. Resurface the crankshaft pins and journals if measurements exceed specifications.

Item	Limit (Diameter)
Roundness Taper	0.01 mm(0.0004 in.)

To determine the oil clearance of the crank pins, measure the diameter of crank pin and compare to the following chart (Figure 5-108) and (Figure 5-109).

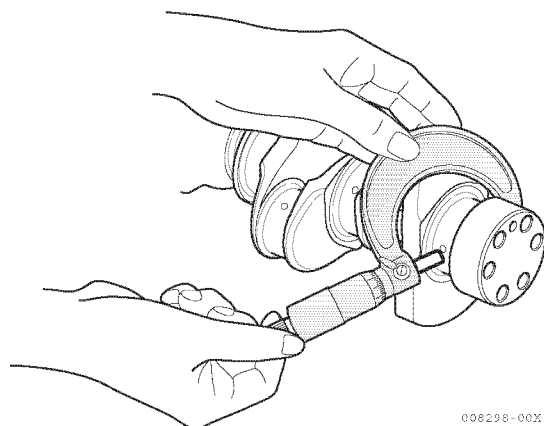

Figure 5-108

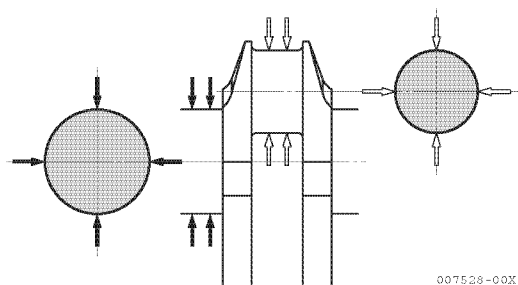

Figure 5-109

		Standard	Limit
Crank Pin	Outside Dia.	47.952~47.962 mm (1.8878 ~ 1.8883 in.)	47.91 mm (1.8862 in.)
	Oil Clearance	0.038~0.074 mm (0.0015~0.0029 in.)	0.150 mm (0.0060 in.)
Crank Journal	Outside Dia.	49.952~49.962 mm (1.9666~1.9670 in.)	49.75 mm (1.9587 in.)
	Oil Clearance	0.038~0.068 mm (0.0015~0.0017 in.)	0.150 mm (0.0059 in.)

- Use dimension R for grinding the crankshaft journals and pins (Figure 5-110) below.

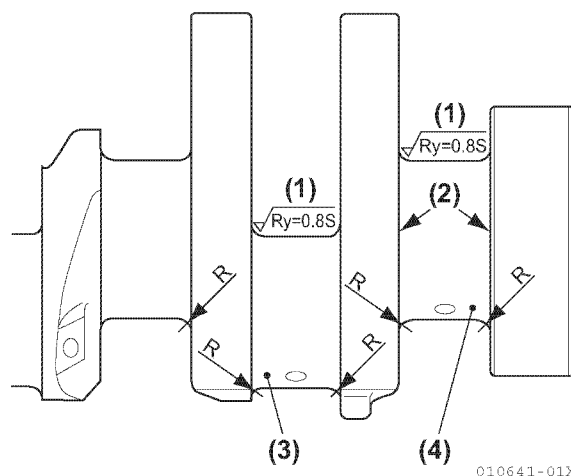

Figure 5-110

- 1 – Super Polishing
- 2 – Thrust Face
- 3 – Crank Pin
- 4 – Crank Journal

Surface finishing standard on journal and pin:
 $Ry=0.8S$ super polishing
 Surface finishing standard on the thrust side of crankshaft arm:

Finishing Standard Of Dimension R
3.5 +0.3 / 0 mm (0.138 +0.012 / 0 in.)

NOTICE:

- If oil clearances are excessive or if partial uneven wear is indicated on the crankpins and / or main bearing journals, re-grind the crankshaft and use oversized bearings.
- If oxidation or other surface imperfections are apparent on the back side of the bearing insert, clean and coat the back surface with machinist's blue dye. Install the bearing inserts in the connecting rod and tighten the cap to the specified torque. Disassemble and check the bearing surface contact. If the contact surface equals 75% or more, the bearing is normal. If the contact surface is less, the bearing contact surface is insufficient. Replace bearing with a new one.
- After assembling the crankshaft, tighten the main bearing caps to the specified torque, and move the crankshaft forward and aft. Place a dial gauge on one end of the crankshaft to measure thrust clearance (Figure 5-111). Replace the thrust bearing if it exceeds the limit.

	Standard	Limit
Crankshaft Side Gap	0.14 ~ 0.22 mm (0.0055 ~ 0.0087 in.)	0.30 mm (0.0118 in.)

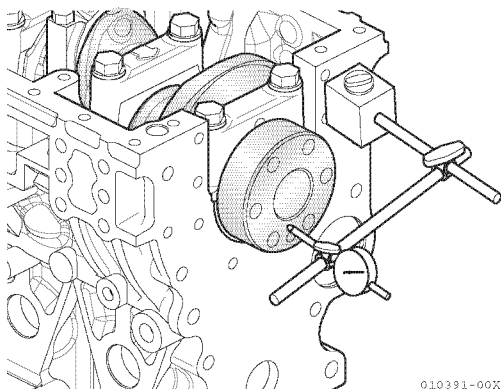

Figure 5-111

A second method of measuring thrust clearance is to insert a thickness gauge directly into the space between the thrust bearing and crankshaft thrust face (Figure 5-112).

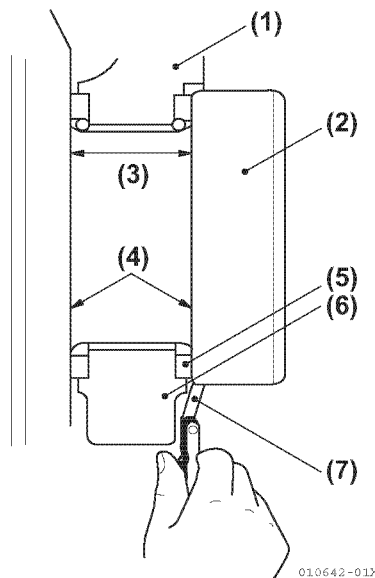

Figure 5-112

- 1 – Cylinder block
- 2 – Crankshaft
- 3 – Standard Width
- 4 – Thrust Face
- 5 – Thrust Bearing
- 6 – Bearing Cap
- 7 – Thickness gauge

Main Bearing

Inspect the main bearing.

- Check for flaking, seizure or discoloration of the contact surface.
- Replace if necessary.

- Tighten the cap to the specified torque and measure the inner diameter of the bearing.

Tightening Torque	96-100 N·m (70.8-73.8 lb-ft)
-------------------	---------------------------------

Inspection Items		Standard	Limit
Crank Journal (Selective Pairing)	Journal Outside Diameter	49.952 - 49.962 mm (1.9667 - 1.9670 in.)	49.902 mm (1.9646 in.)
	Bearing Inside Diameter	51.000 - 51.010 mm (2.0079 - 2.0083 in.)	-
	Bearing Thickness	1.995 - 2.010 mm (0.0785 - 0.07913 in.)	-
	Clearance	0.038 - 0.068 mm (0.00150 - 0.00268 in.)	0.150 mm (0.00591 in.)

Note: When assembling the bearing cap, keep the following in mind.

- The lower bearing insert (cap side) has no oil groove.
- The upper bearing insert (block side) has an oil groove.
- Check the cylinder block alignment number.
- The “FW” on the cap is used on the flywheel end.

Camshaft and Tappets

Camshaft

The camshaft is normalized and the cam and bearing surfaces are surface hardened and ground. The cams have a curve that minimized the repeated shocks on the valve seats and maximizes valve seat life (Figure 5-113).

3JH4E Camshaft Shown

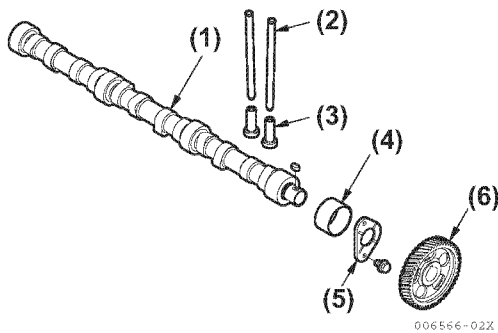

Figure 5-113

- 1 – Camshaft
- 2 – Push Rod
- 3 – Tappet
- 4 – Camshaft Bushing
- 5 – Thrust Metal
- 6 – Camshaft Gear

- Checking the camshaft side gap. Measure the thrust gap before disassembly. As the cam gear is shrink-fitted to the cam, be careful when replacing the thrust bearing (Figure 5-114).

	Standard	Limit
Camshaft Side Gap	0.05 ~ 0.20mm (0.0020 ~ 0.0079 in.)	0.35mm (0.0138 in.)

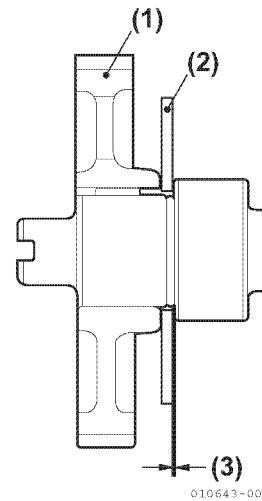

Figure 5-114

- 1 – Camshaft Gear
- 2 – Thrust Metal
- 3 – Camshaft Side Gap

- Measure the camshaft height, and replace the cam if it is worn beyond the limit (Figure 5-115).

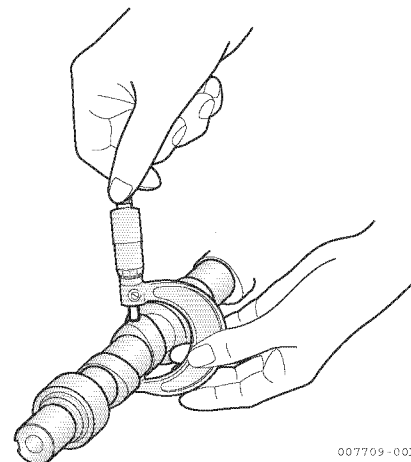

Figure 5-115

		3JH4E/4JH4AE		4JH4-TE/4JH4-HTE	
		Standard	Limit	Standard	Limit
Cam Height	Intake	38.600-38.800mm (1.5197-1.5276 in.)	38.350mm (1.5098 in.)	39.800-40.000mm (1.5669-1.5748 in.)	39.550mm (1.5571 in.)
	Exhaust			37.800-38.000mm (1.4882-1.4961 in.)	37.550mm (1.4783 in.)

- Measure the camshaft outside diameter with a micrometer (**Figure 5-116**). The oil clearance shall be calculated by subtracting the measured camshaft outside diameter from the inside diameter of the camshaft bearing or bushing. The camshaft bushing at gear case side is measured with a cylinder gauge after insertion to the cylinder (**Figure 5-116**). Replace if they exceed the limit or are damaged.

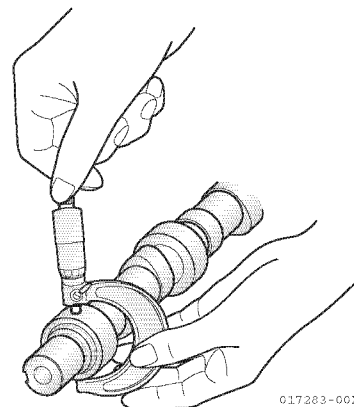

Figure 5-116

Place	Item	Standard	Limit
Gear Side	Bushing ID	44.990 - 45.055 mm (1.771 - 1.774 in.)	45.130 mm (1.777 in.)
	Camshaft O.D.	44.925 - 44.950 mm (1.769 - 1.770 in.)	44.890 mm (1.7673 in.)
	Oil Clearance	0.040 - 0.130 mm (0.0016 - 0.0051 in.)	0.240 mm (0.0009 in.)
Intermediate Position (Metal Less)	Bushing ID	45.000 - 45.025 mm (1.772 - 1.773 in.)	45.100 mm (1.7760 in.)
	Camshaft O.D.	44.910 - 44.935 mm (1.768 - 1.7691 in.)	44.875 mm (1.7667)
	Oil Clearance	0.065 - 0.115 mm (0.0026 - 0.0045 in.)	0.225 mm (858 in.)
Flywheel End (Metal Less)	Bushing ID	45.000 - 45.025 mm (1.772 - 1.773 in.)	45.100 mm (1.7756 in.)
	Camshaft O.D.	44.925 - 44.950 mm (1.769 - 1.770 in.)	44.890 mm (1.7674 in.)
	Oil Clearance	0.050 - 0.100 mm (0.0020 - 0.0039 in.)	0.210 mm (0.00827 in.)

- Support both ends of the crankshaft with V-blocks, place a dial gauge at the central bearing areas and measure bending (**Figure 5-117**). Replace if excessive.

Note: The reading on the dial gauge is divided by two to obtain the camshaft bend .

	Standard	Limit
Camshaft Bend	0.02 or less mm (0.0008 or less in.)	0.05 mm (0.002 in.)

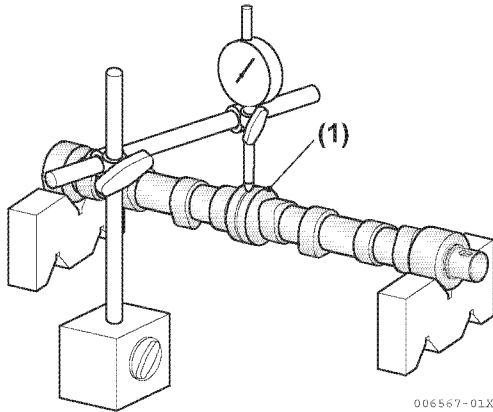

Figure 5-117

1 – Camshaft Central Bearing Area

Tappets

The tappets are offset to rotate during operation and thereby prevent uneven wearing. Check the contact of each tappet and replace if excessively or unevenly worn.

Note: When removing tappets, be sure to keep them separate for each cylinder and intake/exhaust valve (**Figure 5-118**).

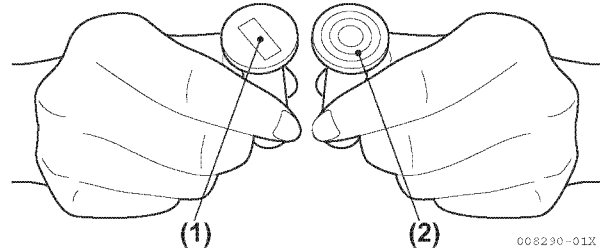

Figure 5-118

- 1 – Abnormal Contact Surface**
- 2 – Normal Contact Surface**

Measure the outer diameter of the tappet, and replace if worn beyond the limit (**Figure 5-119**).

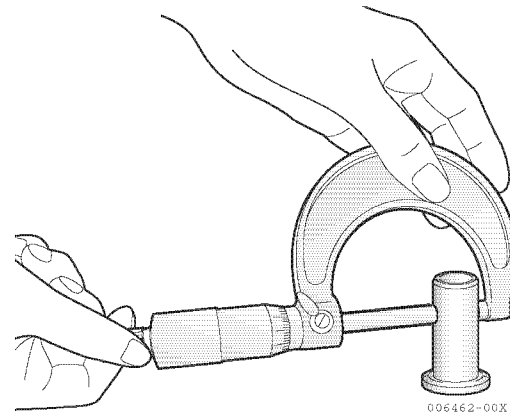

Figure 5-119

	3JH4E/4JH4AE		4JH4-TE/4JH4-HTE	
	Standard	Limit	Standard	Limit
Tappet Stem Outside Dia.	11.975 ~ 11.990 mm (0.4715 ~ 0.4720 in.)	11.930 mm (0.4697 in.)	11.975 ~ 11.990 mm (0.4715 ~ 0.4720 in.)	11.930 mm (0.4697 in.)
Tappet Guide Hole Inside Dia. (Cylinder Block)	12.000 ~ 12.018 mm (0.4724 ~ 0.4731 in.)	12.045 mm (0.4742 in.)	12.000 ~ 12.025 mm (0.4724 ~ 0.4734 in.)	12.052 mm (0.4745 in.)
Oil Clearance	0.010 ~ 0.043 mm (0.0004 ~ 0.0017 in.)	0.090 mm (0.0035 in.)	0.010 ~ 0.050 mm (0.0004 ~ 0.0020 in.)	0.097 mm (0.0038 in.)

Push Rods

Measure the length and bending of the push rods (Figure 5-120).

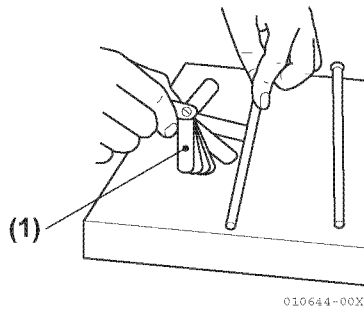

Figure 5-120

1 – Thickness Gauge

	Standard	Limit
Push Rod Length	178.25~178.75 mm (7.018~7.037 in.)	-
Push Rod Bend	Less than 0.03 mm (Less than 0.0012 in.)	0.3 mm (0.012 in.)
Push Rod Dia.	8.5 mm (0.3346 in.)	-

Timing Gear

The timing gear is helical type for minimum noise and specially treated for high durability.

Gear Inspection

- Inspect the gears and replace if the teeth are damaged or worn.
- Measure the backlash of all gears that mesh, and replace the meshing gears as a set if wear exceeds the limit.

Note: If backlash is excessive, it will not only result in excessive noise and gear damage, but also lead to bad valve and fuel injection timing and a decrease in engine performance.

	Standard	Limit
Backlash	0.07 - 0.15 mm (0.0018 - 0.0059 in.)	0.17 mm (0.0067 in.)

- The bushing is pressed into the idling gear. Measure the bushing inner diameter and the outer diameter of the shaft, and replace the bushing or idling gear shaft if the oil clearance exceeds the wear limit (Figure 5-121).

A, B and C are inscribed on the end of the idling gear. When assembling, these marks should align with those on the cylinder block.

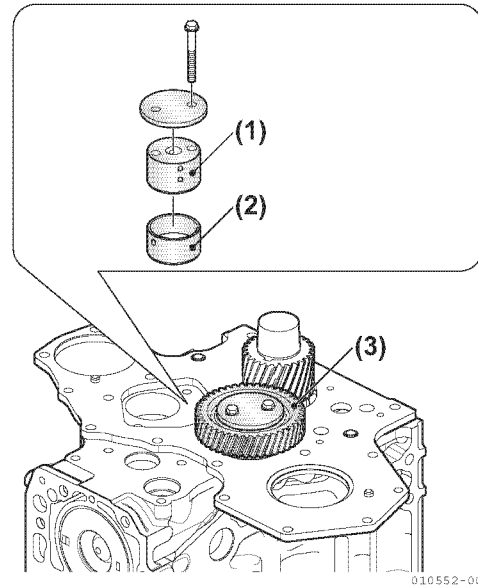

Figure 5-121

- 1 – Idle Gear Shaft
- 2 – Idle Gear Bushing
- 3 – Idle Gear

	Standard	Limit
Idle Shaft Dia.	45.950 ~ 45.975 mm (1.809 ~ 1.810 in.)	45.880 mm (1.806 in.)
Idle Gear Bushing Inside Dia.	46.000 ~ 46.025 mm (1.811 ~ 1.812 in.)	46.075 mm (1.814 in.)
Oil Clearance	0.025 ~ 0.075 mm (0.00098 ~ 0.0030 in.)	0.15 mm (0.0059 in.)

Gear Timing Marks

Match up the timing marks on each gear when assembling (A,B and C) (Figure 5-122).

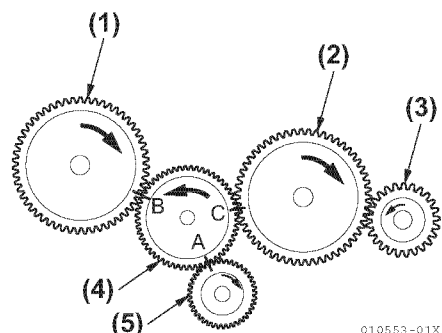

Figure 5-122

- 1 – Fuel Injection Pump Drive Gear
- 2 – Camshaft Gear
- 3 – Seawater Pump gear
- 4 – Idle Gear
- 5 – Camshaft Gear

Flywheel and Housing

The function of the flywheel is through inertia, to rotate the crankshaft in a uniform and smooth manner by absorbing the turning force created during the combustion stroke of the engine, and by compensating for the decrease in turning force during the other strokes.

The flywheel is mounted and secured by 6 bolts on the crankshaft end at the opposite end to the gear case; it is covered by the mounting flange (flywheel housing) which is bolted to the cylinder block.

The fitting surface for the damper disk is on the crankshaft side of the flywheel. The rotation of the crankshaft is transmitted through this disk to the input shaft of the reduction and reversing gear. The reduction and reversing gear is fitted to the mounting flange.

The flywheel's unbalanced force on the shaft center must be kept below the specified value for the crankshaft as the flywheel rotates with the crankshaft at high speed.

To achieve this, the valance is adjusted by drilling holes in the side of the flywheel, and the unbalanced momentum is adjusted by drilling holes in the circumference.

The ring gear is shrink fitted onto the circumference of the flywheel, and this ring gear serves to start the engine by meshing with the starter motor pinion.

The stamped letter and line which show top dead center of each cylinder are positioned on the flywheel circumference, and by matching these marks with the arrow mark at the hole of the flywheel housing, the rotary position of the crankshaft can be ascertained in order to adjust tappet clearance or fuel injection timing.

Position of Top Dead Center and Fuel Injection Timing

- The marking is applied on the flywheel to show the crankshaft angle (Figure 5-123).

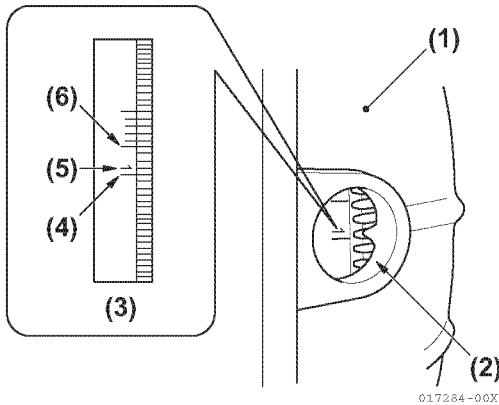

Figure 5-123

- 1 – Flywheel Housing
- 2 – Hole
- 3 – Flywheel
- 4 – T.D.C
- 5 – No.1 Cylinder
- 6 – Injection Timing Mark

- The matching mark is made at the hole of the flywheel housing (Figure 5-124).

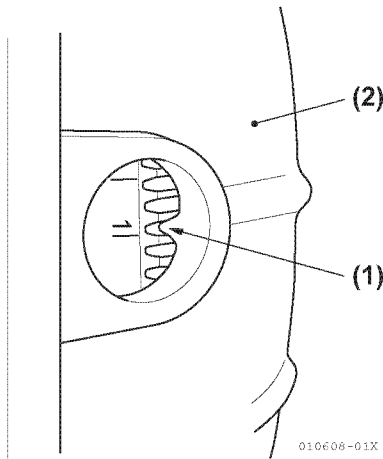

Figure 5-124

- 1 – Matching Mark
- 2 – Flywheel Housing

Damper Disk and Cooling Fan

When coupling a marine gear with an engine, a damper disk is used to absorb the torque fluctuations of the engine. Refer to the marine gear service manual of the separate volume for the detail.

Damper Disk (Parts No.: 177090-03500) for KM4A2 Marine Gear.

Torsional Rigidity	22.3 N·m / rad (16.45 lb-ft / rad)
Maximum Angle of Torsion	7.3×10^{-2} rad
Stopper Torque	2.12 N·m (1.565 lb-ft)

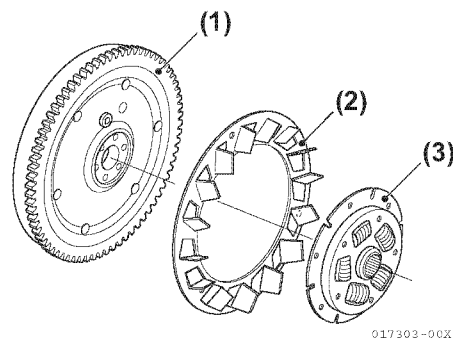

Figure 5-125

- 1 – Flywheel
- 2 – Cooling Fan
- 3 – Damper Disk

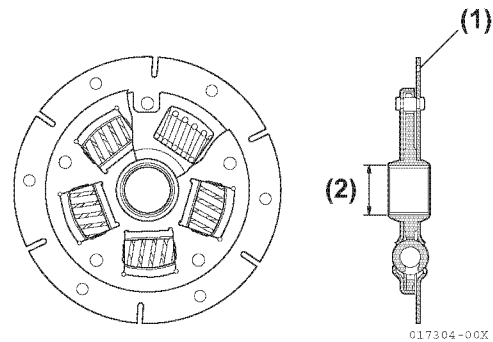
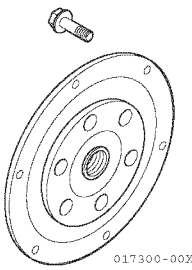
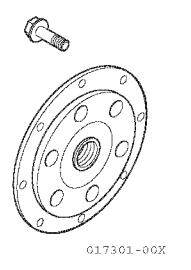
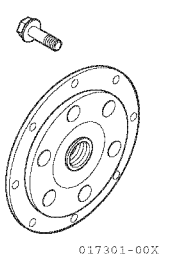
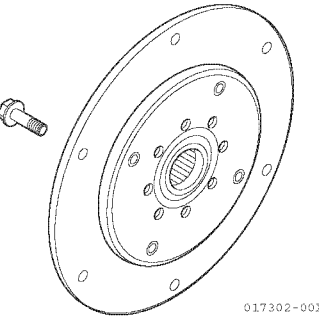

Figure 5-126

- 1 – Flywheel End
- 2 – Spline SAE 20/40

Damper Discs for KMH4A, ZF25M, ZF30M and SD50

Marine Gear	KMH4A	ZF25M	ZF30M	SD50
Damper Disk Parts No.	129673-81760	129673-81150	129673-81250	196440-04300
	 <p>017300-00X</p>	 <p>017301-00X</p>	 <p>017301-00X</p>	 <p>017302-00X</p>

ASSEMBLY

To reassemble the engine, perform the following preliminary steps:

1. Clean all parts using a cloth and clean diesel fuel or other cleaning agent.
 - Dust remaining on engine parts may cause seizing or other damage.
 - Cleaning agents will remove carbon adhering to disassembled parts.
2. Place a wood block on the floor and place the cylinder block upside down with the cylinder head mounting surface facing down (Figure 5-127).

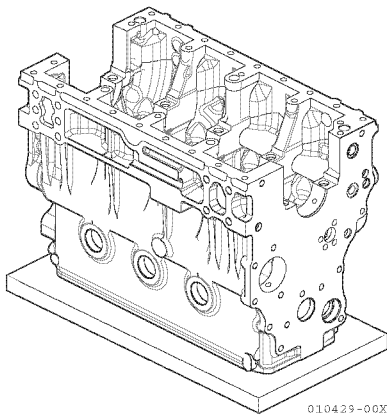

Figure 5-127

3. Coat the inside of the cylinder block tappet holes and the outside circumference of the tappets with engine oil, then insert the tappets in the cylinder block (Figure 5-128).

Note: Separate the tappets to make sure that they are reassembled in the same cylinder No. and intake / exhaust side as they came from.

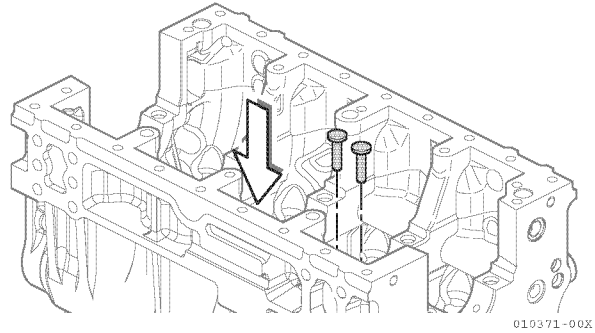

Figure 5-128

4. Install the crankshaft (Figure 5-129):

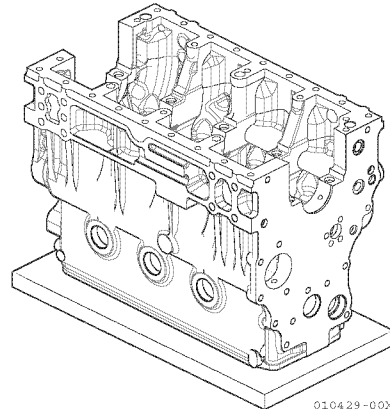
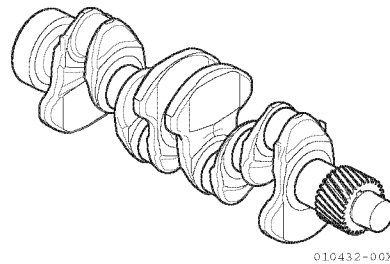

Figure 5-129

- The crankshaft and the crankshaft gear are shrink-fitted. If the crankshaft and the crankshaft gear have been disassembled, they have to be shrink-fitted. Heat the crankshaft gear to 180-200°C (356-392°F) in hot oil and press fit to the crankshaft.
 - Coat the crank journal part of the cylinder block and the upper main bearing with engine oil, then fit the upper main bearing onto the cylinder block.
 - Be sure not to confuse the upper and lower main bearings. The upper bearing has an oil groove.
 - When mounting the thrust bearing, fit it so that the surface with the oil groove faces outwards on the crankshaft side.
 - Coat the crank pins and the crank journals of the crankshaft with engine oil and the crankshaft on the upper main bearings.
 - Position the crankshaft so that the crankshaft gear is on the gear case side.
 - Do not let the thrust bearing drop.
5. Coat the lower main bearing with engine oil, and mount it to the main bearing cap (Figure 5-130).

- The lower main bearing does not have an oil hole.
- The base thrust bearing is fitted with the oil groove facing outwards.

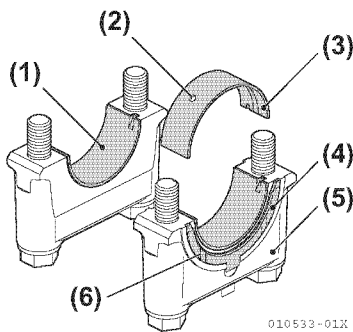

Figure 5-130

- 1 – Lower Main Bearing
- 2 – Oil Hole
- 3 – Upper Main Bearing
- 4 – Thrust Bearing
- 5 – Main Bearing Cap (Base)
- 6 – Groove

6. Coat the flange and the thread of the main bearing bolts with engine oil, put them on the crankshaft journal, and tighten the main bearing bolts to the specified torque (Figure 5-131).

Tightening Torque

Main bearing bolt	96-100 N·m (71-74 lb-ft)
-------------------	--------------------------

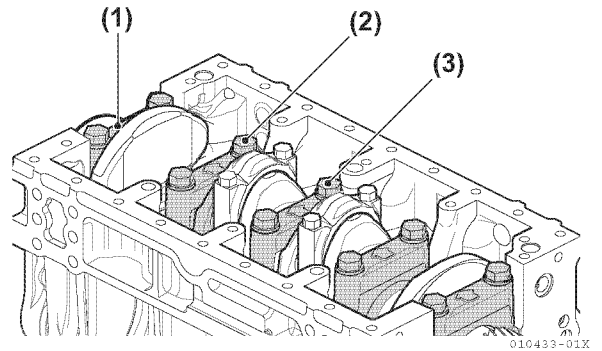

Figure 5-131

- 1 – Main Bearing Cap (Base)
- 2 – Main Bearing Cap
- 3 – Main Bearing Bolt

Note:

- The main bearing cap should be mounted with the arrow on the cap pointing toward the flywheel. Ensure the cylinder alignment number is correct (Figure 5-132).

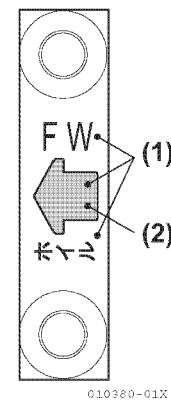

Figure 5-132

- 1 – Mark
- 2 – Flywheel End

7. Measure the crankshaft side clearance. Ensure the crankshaft rotates smoothly.

Crankshaft Side Clearance	Standard	Limit
	0.140~0.220 mm (0.0055 +0.0031 in.)	0.28 mm (0.011 in.)

8. Install a new oil seal. Press the oil seal in the oil seal case. Coat the lip of the oil seal with engine oil (Figure 5-133).

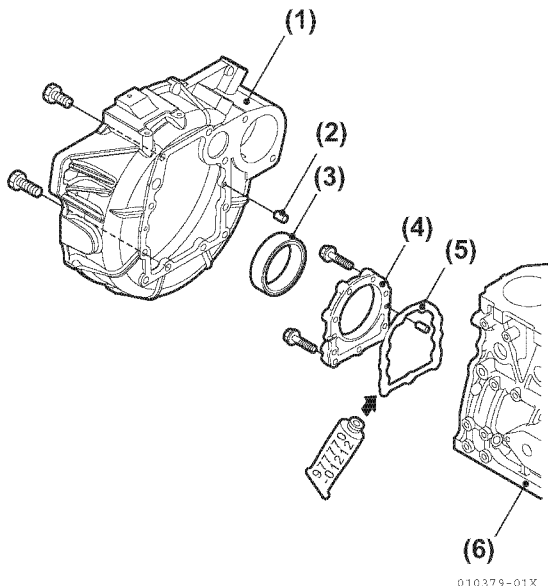

Figure 5-133

- 1 – (Flywheel Housing
- 2 – Parallel Pin
- 3 – Oil Seal
- 4 – Oil Seal Case
- 5 – Liquid Gasket
- 6 – Cylinder Block

9. Apply liquid gasket to the mounting surface of the oil seal case. Mount the oil seal case to the cylinder block, while matching up the cylinder block positioning pins (Figure 5-133).

Note: Be careful that the liquid gasket does not protrude onto the oil pan mounting surface.

10. Mount the flywheel housing to the cylinder block, while matching up with the cylinder block positioning pins (Figure 5-133).

11. Stand the engine on the flywheel housing (Figure 5-134).

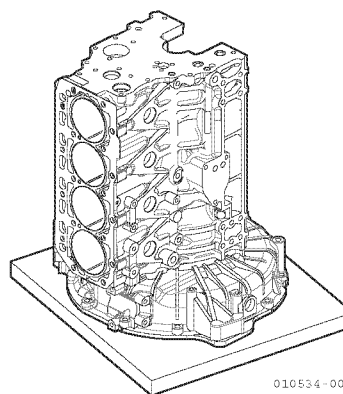

Figure 5-134

12. Apply the liquid gasket to the gear case flange. Mount the gear case and lubricating oil line O-ring to the cylinder block (Figure 5-135).

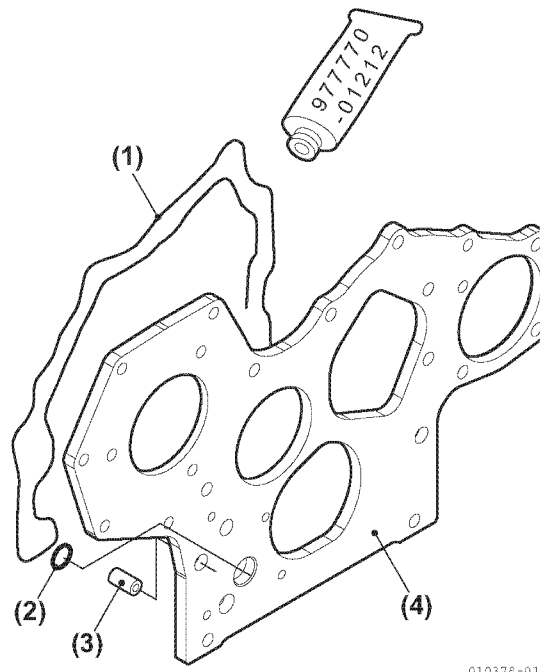

Figure 5-135

- 1 – Liquid Gasket
- 2 – O-ring
- 3 – Knock Pin
- 4 – Gear Case

- When mounting the gear case, match the two cylinder block knock pins.
- Coat the O-ring for the cylinder block with lubricating oil and line with grease before installing (Figure 5-135).

13. Assemble the piston and connecting rod.

- When assembling the piston and connecting rod, ensure correct orientation.
- Install each piston ring on the piston, with the punched manufacturer's mark facing upward (Figure 5-136).

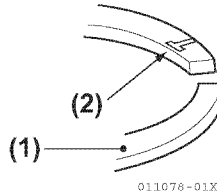

Figure 5-136

- 1 – Piston Ring
- 2 – Punched Manufacturer's Mark

- The piston ring joints must be staggered at 120° to each other. Do not position the top ring joint in line with the piston pin (Figure 5-137) and (Figure 5-138). The coil expander joint must be opposite the oil ring joint (Figure 5-139).

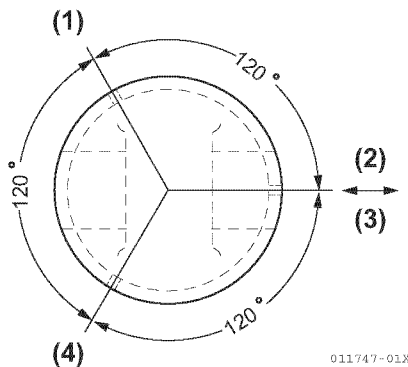

Figure 5-137

- 1 – 1st Piston Ring Gap
- 2 – Direction of Piston Pin
- 3 – Oil Ring Gap
- 4 – 2nd Piston Ring Gap

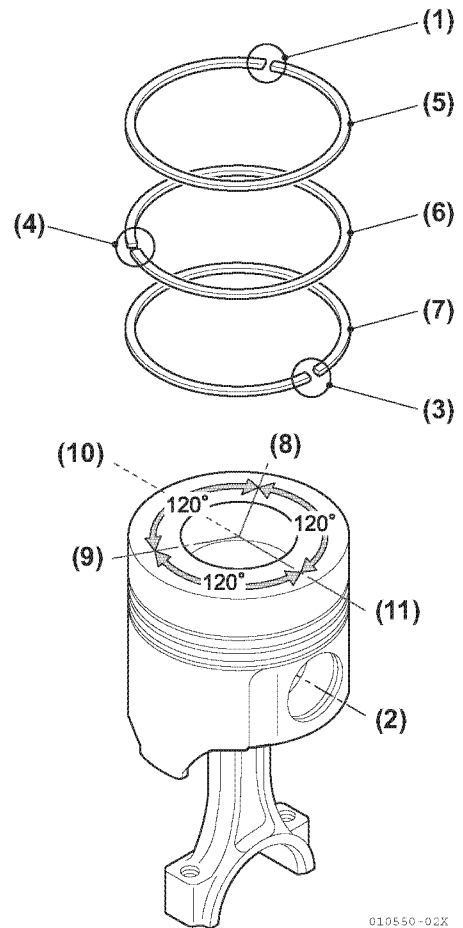

Figure 5-138

- 1 – 1st Piston Ring Gap
- 2 – Direction of Piston Pin
- 3 – Oil Ring Gap
- 4 – 2nd Piston Ring Gap
- 5 – 1st Piston Ring
- 6 – 2nd Piston Ring
- 7 – Oil Ring
- 8 – 1st Piston Ring Gap
- 9 – 2nd Piston Ring Gap
- 10 – Expander Joint
- 11 – Oil Ring Gap

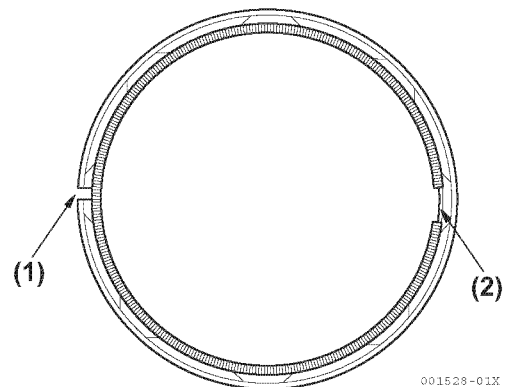

Figure 5-139

- 1 – Gap
- 2 – Joint of Coil Expander

14. Coat the outside of the piston and the inside of the crank pin bearing with engine oil and insert the piston by using the piston insertion tool.

- Insert the piston so that the match mark on the large end of the connecting rod faces the fuel nozzle, and the manufacturer's embossed mark on the stem faces toward the flywheel.
- After inserting the piston, make sure the ID marks (size mark and model mark) on the piston top are in the correct position, looking from the top of the piston (**Figure 5-140**) and (**Figure 5-141**).

3JH4E and 4JH4AE Engines

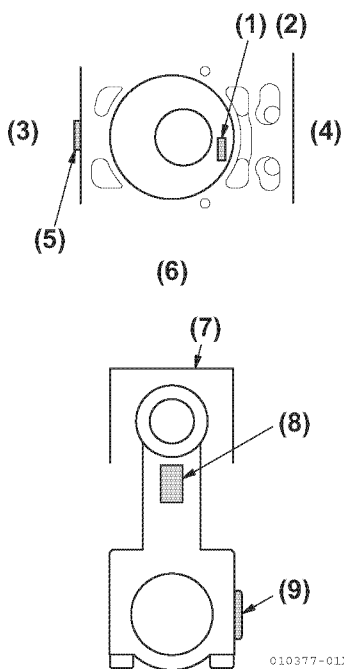

Figure 5-140

- 1 – Size Mark
- 2 – Model Mark
- 3 – Camshaft Side
- 4 – Nozzle Side
- 5 – Cylinder Size Mark
- 6 – Flywheel End
- 7 – Piston ID Mark
- 8 – Embossed Mark (Flywheel End)
- 9 – Match Mark

4JH4-TE and 4JH4-HTE Engines

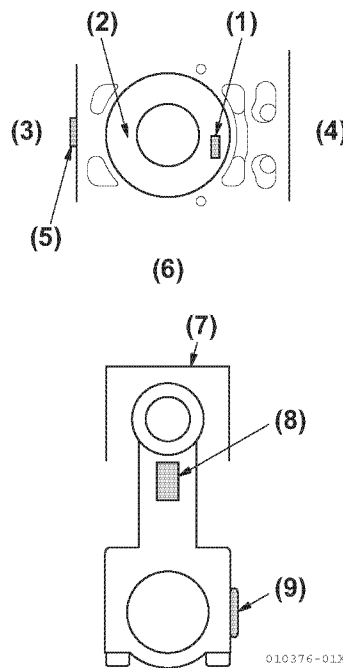

Figure 5-141

- 1 – Size Mark
- 2 – Model Mark
- 3 – Camshaft Side
- 4 – Nozzle Side
- 5 – Cylinder Size Mark
- 6 – Flywheel End
- 7 – Piston ID Mark
- 8 – Embossed Mark (Flywheel End)
- 9 – Match Mark

- When inserting the piston / connecting rod assembly, ensure it does not hit the large end of the connecting rod with the piston cooling nozzle (4JH4-(H)TE) mounted on the back of the cylinder block. If this happens, the cooling nozzle may warp or be damaged.
- Align the large end match mark, mount the cap, and tighten the connecting rod bolts.

Tightening Torque

Connecting Rod Bolt	44.1-49.1 N·m (32.5-36.2 lb-ft)
---------------------	------------------------------------

- Note: If a torque wrench is not available, match up with the mark made before disassembly.

15. If the camshaft and the camshaft gear have been disassembled, shrink fit the camshaft and the camshaft gear. Heat the camshaft gear in hot oil to 180-220°C (356-428°F) and press fit onto the camshaft.

Note: Ensure the thrust bearing assembly is in place when mounting the camshaft, ensuring orientation is correct.

16. Coat the cylinder block camshaft bearings and camshaft with engine oil, insert the camshaft in the cylinder block, and tighten the thrust bearing bolts.

17. Measure the camshaft side gap (Figure 5-142). Ensure the camshaft rotates smoothly.

Camshaft Side Gap	Standard	Limit
	0.05~0.20 mm (0.002~0.008 in.)	0.30 mm (0.012 in.)

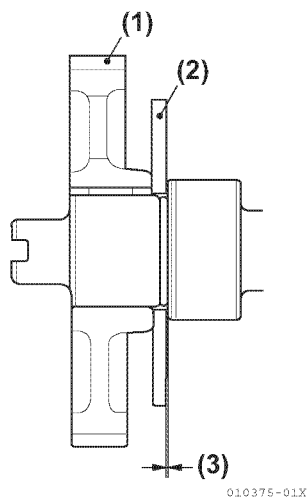

Figure 5-142

- 1 – Camshaft Gear
- 2 – Thrust metal
- 3 – Side Gap

18. Install the idling gear with the oil hole of the idle gear shaft faces up.

Note: The idle gear shaft must be installed with the shaft marking upward (Figure 5-143).

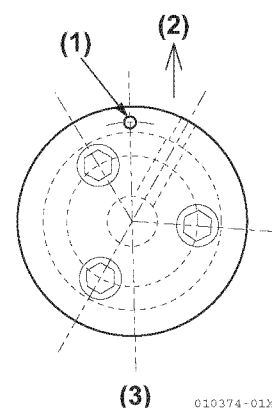

Figure 5-143

- 1 – Mark
- 2 – UP Side
- 3 – Idle Gear Shaft

19. Align the “A” and “C” match marks of the idle gear with the match marks of the camshaft gear and the crankshaft gear.

20. Measure the idle gear, camshaft gear and crankshaft gear backlash (Figure 5-144).

Backlash	Standard	Limit
	0.07-0.15 mm (0.003-0.006 in.)	0.17 mm (0.0067 in.)

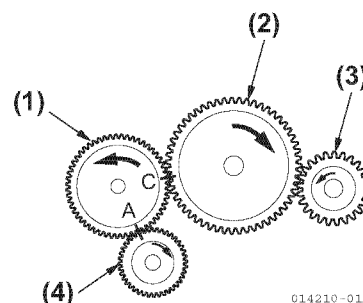

Figure 5-144

- 1 – Idle Gear
- 2 – Camshaft Gear
- 3 – Seawater Pump Gear
- 4 – Crankshaft Gear

21. Mount the lubricating oil pump to the gear case cover:

Tightening Torque

Bolt	5.4-8.4 N·m (4.0-6.2 lb-ft)
------	--------------------------------

- Before installing the outer / inner rotors, coat them with lubricating oil (10W30).
- Assemble the rotor so that the concave mark of the rotor is on the cover side.
- Ensure the rotor rotates smoothly.

22. Mount the gear case cover (**Figure 5-145**):

- Install a new oil seal. Coat the inside and outside of the oil seals with lubricating oil and press fit it into the gear case.
- Apply liquid gasket to the gear case cover. Position the two knock pins and tighten the gear case bolts.

Note: Trim the liquid gasket material if it protrudes onto the oil pan mounting surface.

3JH4E and 4JH4AE Engines Shown

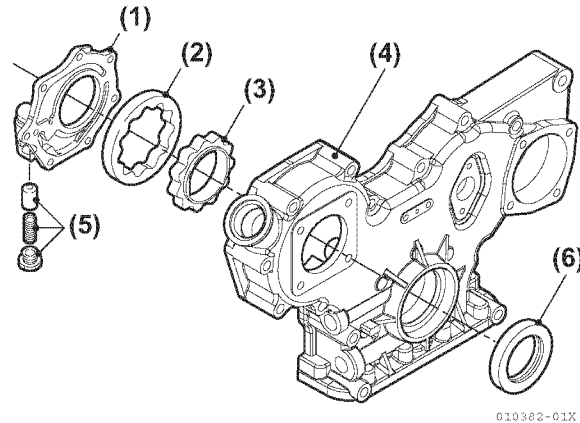

Figure 5-145

- 1 – Lubricating Oil Pump**
- 2 – Outer Rotor**
- 3 – Inner Rotor**
- 4 – Gear Case**
- 5 – Pressure Control Valve**
- 6 – Oil Seal**

23. Install the lubricating oil inlet pipe on the bottom of the cylinder block, using a new gasket.

Tightening torque

Lubricating Oil Inlet Pipe	26 N·m (19 lb-ft)
----------------------------	----------------------

- 24. Apply liquid gasket to the surfaces of the gear case cover, gear case and oil seal case on the flywheel housing side that contact the cylinder block.
- 25. Apply liquid gasket to the spacer. Install the spacer to the cylinder block and tighten the bolts.
- 26. Apply liquid gasket to the oil pan. Install the oil pan to the spacer and tighten the bolts.

27. Install the dipstick and dipstick guide.

Note: There are three surfaces requiring sealing for 4JH4AE

- Check the level gap of the three surfaces.
- Apply Three Bond 1207F to the three surfaces (Figure 5-146).

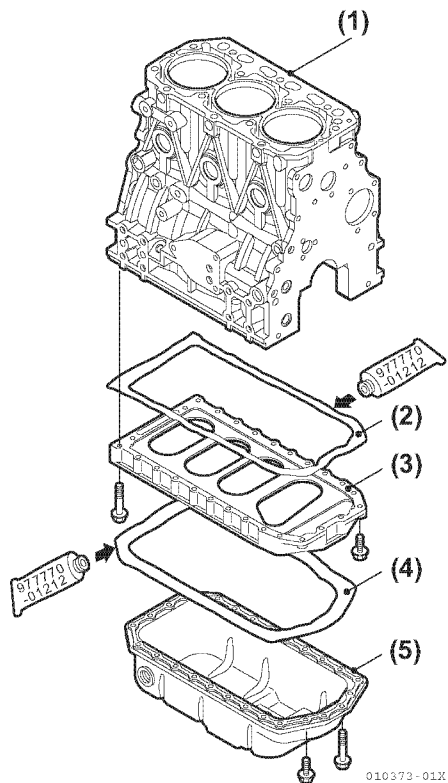

Figure 5-146

- 1 – Cylinder Block
- 2 – Liquid Gasket
- 3 – Spacer
- 4 – Liquid Gasket
- 5 – Oil Pan

28. Install the crankshaft V-pulley.

- Coat the oil seal with oil.
- Wipe oil from the taper surface.
- Tighten to the specified torque.

Tightening Torque

V-pulley bolt (Material: casting iron)	83.2-93.2 N·m (61.3-68.7 lb-ft)
---	------------------------------------

29. Install the engine mounting feet and turn the engine upright.

30. Install the flywheel

- Coat the flywheel bolt threads with lubricating oil.
- Align the positioning pins, and tighten the flywheel bolts to the specified torque (Figure 5-147).

Tightening Torque

Flywheel bolt	83.3-88.3 N·m (61.4-65.1 lb-ft)
---------------	------------------------------------

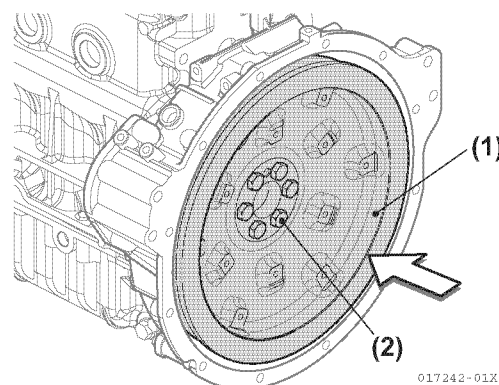

Figure 5-147

- 1 – Flywheel
- 2 – Flywheel Bolt

31. Install the marine gear:

- Install the damper disk to the flywheel.
- Align the damper disk with the input shaft spline and insert.
- Install the marine gearbox to the flywheel housing.

32. Install the cylinder head. *NOTICE: Ensure the threaded bolt holes are clean and dry. If coolant or oil remains in the holes, there is a risk of cracking the cylinder block when the bolts are installed.*

- Replace the old cylinder head gasket with new one.
- Put the cylinder head gasket on the cylinder block, aligning it with the cylinder block positioning pins.

Note: Select the proper head gasket using the holes shown in **Figure 5-148** for identification.

4JH4AE, 4JH4-TE and 4JH4-HTE Engines Shown

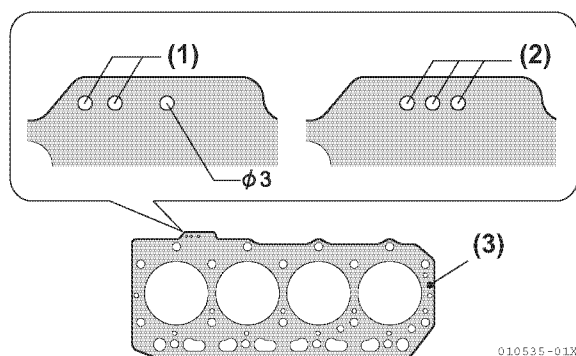
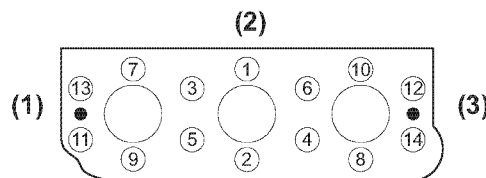

Figure 5-148

- 1 – Identification Holes 2-Ø3**
- 2 – Identification Holes 3-Ø3**
- 3 – Head Gasket**

- Lift the cylinder head horizontally and mount it aligning with the cylinder head gasket.

- Coat the flange part and thread of the cylinder head bolt with lubricating oil, and lightly tighten the bolts in the specified order.
- Then tighten to specified values in the same order.
- **Figure 5-149** shows head bolt tightening order for 3JH4E and **Figure 5-150** shows 4JH4AE, 4JH4-TE and 4JH4-HTE.



017243-00X

Figure 5-149

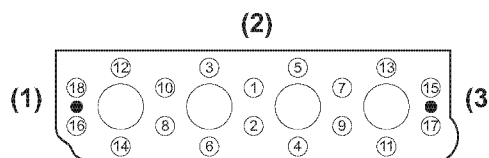

017244-00X

Figure 5-150

- 1 – Flywheel End**
- 2 – Camshaft Side**
- 3 – Gear Case Side**

Tightening Torque

	1 st step	Final
Cylinder head bolt	39.2-49.1 N·m (28.9-36.2 lb-ft)	85.2-91.2 N·m (62.9-67.3 lb-ft)

- Measure the top clearance. See *Measure Top Clearance* on page 5-60.

Clearance

Top clearance	0.74 ± 0.06 mm (0.029 ± 0.002 in.)
---------------	---------------------------------------

33. Install the rocker arm shaft assembly and pushrods:
- Fit the push rod to the tappet.
 - Coat the top of the push rod and the adjusting bolt of the rocker arm with lubricating oil. Install the rocker arm shaft assembly to the cylinder head. Apply lubricating oil to the bolt, locknut and hatched area of push rod.

Tightening Torque

Rocker Arm Shaft Support	24-27 N·m (18-20 lb-ft)
--------------------------	----------------------------

- Adjust valve clearance.

Clearance

Intake/Exhaust Valve Clearance	0.15-0.25 mm (0.0059-0.0098 in.)
--------------------------------	-------------------------------------

- Coat the rocker arm and valve spring with lubricating oil and install the rocker arm cover (**Figure 5-151**) and (**Figure 5-152**).

2-Valve Head

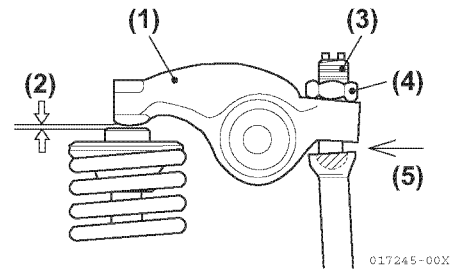

Figure 5-151

- 1 – Rocker Arm
- 2 – Valve Clearance
- 3 – Adjusting Bolt
- 4 – Locknut
- 5 – Engine Oil

4-Valve Head

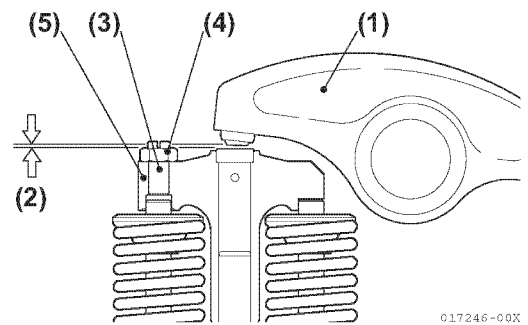

Figure 5-152

- 1 – Rocker Arm
- 2 – Valve Clearance
- 3 – Adjusting Bolt
- 4 – Locknut
- 5 – Valve Bridge (4JH4-TE and 4JH4-HTE only)

34. Adjust valve clearance - 2 valve cylinder head

- Loosen adjusting bolts.
- Loosen the locknut and adjusting bolt, and check the valve for any inclination of valve cap, entrance of dirt or wear.
- Insert a 0.2 mm (0.008 in.) feeler gauge between the rocker arm and valve cap.
- Adjust the valve clearance by turning the adjustment bolt until there is a slight "drag" on the feeler gauge when sliding it between the rocker arm and the valve cap.

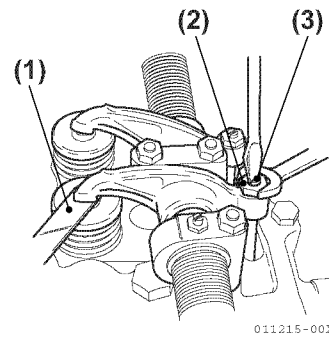

Figure 5-154

- 1 – Feeler Gauge
- 2 – Locknut
- 3 – Adjusting Bolt

Standard Intake/Exhaust Valve Clearance (mm)
0.15-0.25 (0.006-0.010 in.)

- Tighten the locknut.
- Apply oil to the contact surface between adjusting bolt and push rod.
- Adjusting other cylinders. See step 36 on page 5-97.

2 Valve Cylinder Head

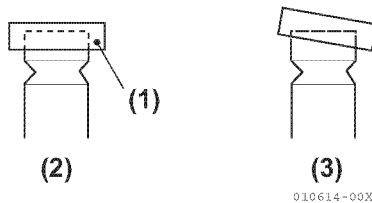

Figure 5-153

- 1 – Valve Cap
- 2 – Normal
- 3 – Abnormal

35. Adjust valve clearance - 4 valve cylinder head

- Loosen adjusting bolts. The 4-valve cylinder head has a valve bridge.
- Remove the injector to make space for inserting a wrench to hold the valve bridge. *NOTICE: Do not loosen or tighten the valve bridge adjusting bolt locknut without holding the valve bridge. Always hold the valve bridge using a wrench to prevent bending of the valve stems and / or valve bridge guide.*
- Loosen the bridge adjusting bolt locknut while holding the bridge with a wrench.
- Loosen the adjusting bolt by turning it 2 turns counterclockwise.
- Check for visible clearance between bolt and valve.

4 Valve Cylinder Head

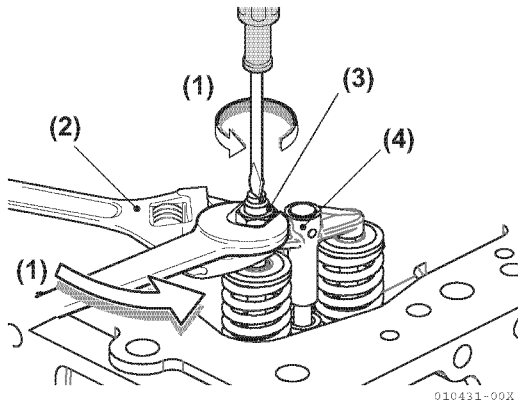

Figure 5-155

- 1 – Loosen
- 2 – Wrench
- 3 – Adjusting Bolt
- 4 – Valve Bridge

Adjusting valve bridge clearance

- The valve bridge on the 4-valve system enables one rocker arm to operate two valves at the same time. The valve bridge should be adjusted exactly in horizontal position.
- The clearance between the valve bridge and valves must be set before adjusting the valve clearance between rocker arm and valve bridge.
- To assure the valve bridge has equal contact with the front and rear valves, apply light pressure to the rocker arm. Screw in the rocker arm adjusting bolt until rocker arm touches the valve bridge.
- Adjust the valve bridge adjusting bolt, so there is zero clearance between the adjustment bolt and the front valve.
- Tighten the locknut while holding the valve bridge with a wrench. Verify that the valve bridge clearance is zero.

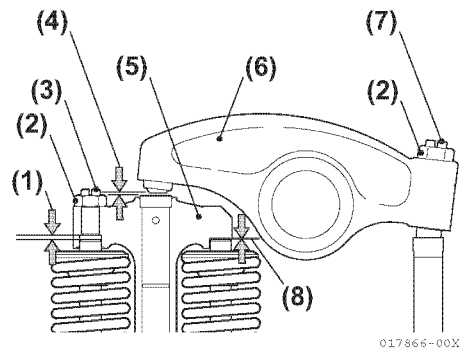

Figure 5-156

- 1 – Adjusting Valve Bridge Clearance To 0
- 2 – Locknut
- 3 – Valve Bridge Adjusting Bolt
- 4 – Valve Clearance
- 5 – Valve Bridge
- 6 – Rocker Arm
- 7 – Rocker Arm Adjusting Bolt
- 8 – Clearance 0

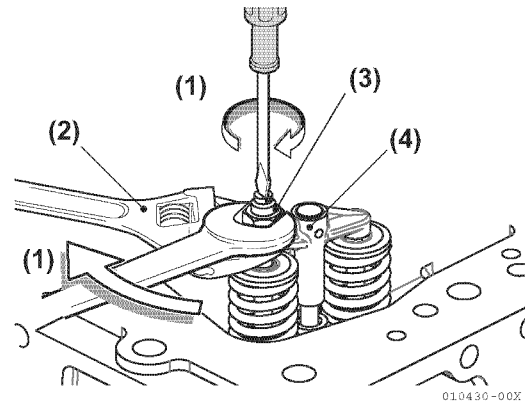

Figure 5-157

- 1 – Tighten
- 2 – Wrench
- 3 – Adjusting Bolt
- 4 – Valve Bridge

Valve clearance adjustment

- Insert a 0.2 mm (0.008 in.) feeler gauge between the rocker arm and valve bridge.
- Adjust the valve clearance by turning the adjustment bolt until there is a slight "drag" on the feeler gauge when sliding it between the rocker arm and the valve bridge.

Standard Intake/Exhaust Valve Clearance (mm)
0.15-0.25 (0.006-0.010 in.)

- Tighten the locknut.
- Apply lubricating oil to the contact surface between adjusting bolt and push rod.

- Adjust other cylinders.
- See step 36 on page 5-97.

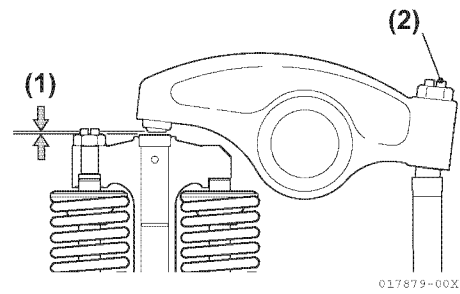

Figure 5-158

- 1 – Valve Clearance**
2 – Rocker Arm Adjusting Bolt

36. Measuring Other Cylinders

- 3JH4E Engine

Turn the crankshaft 240° and make measurement and adjustment for the No. 3 cylinder. Then adjust the No. 2 cylinder.

The cylinder to be measured and adjusted first does not have to be the No. 1 cylinder. Select and adjust the cylinder where the piston is the nearest to the top dead center after turning, and make measurement and adjustment for other cylinders in the order of ignition by turning the crankshaft 240° each time.

The measurement and adjustment method of reducing the flywheel turning numbers (for reference): Set No. 1 cylinder to the compression TDC and adjust the clearance of the ● mark of the below table. Next, turn the flywheel once (the suction/exhaust valve of No. 1 cylinder is in the position of the overlap TDC at this time), and adjust the clearance of the ○ mark.

Ignition order of 3 cylinder engines: 1 → 3 → 2

Cylinder No.	1		2		3		
	Suction	Exhaust	Suction	Exhaust	Suction	Exhaust	
No. 1 Compression T.D.C	●	●	●			●	The first time
No. 1 Overlap T.D.C				○	○		The second time

- 4JH4AE/ 4JH4-TE/ 4JH4-HTE Engines

Turn the crankshaft 180° and make measurement and adjustment for the No. 3 cylinder. Then adjust the No. 4 and No. 2 cylinders according to the order of injection.

The cylinder to be adjusted first does not have to be the No. 1 cylinder. Select and adjust the cylinder where the piston is the nearest to the top dead center after turning, and make adjustment for other cylinders in the order of ignition by turning the crankshaft 180° each time.

The measurement and adjustment method of reducing the flywheel turning numbers (for reference): Set No. 1 cylinder to the compression TDC and adjust the clearance of the ● mark of the bottom table. Next, turn the flywheel once, and adjust the clearance of the ○ mark.

Ignition order of 4 cylinder engines: 1 → 3 → 4 → 2

Cylinder No.	1		2		3		4		
	Suction	Exhaust	Suction	Exhaust	Suction	Exhaust	Suction	Exhaust	
No. 1 Compression T.D.C	●	●	●			●			The first time
No. 4 Compression T.D.C				○	○		○	○	The second time

37. 3JH4E and 4JH4AE Engines:

Install the fuel injection pump (Figure 5-159).
NOTICE: Never remove the bolts for tightening the fuel injection drive gear and fuel injection pump hub. Otherwise fuel injection timing differ from proper set value.

- Lightly fit the fuel injection pump on the gear case.
- After adjusting injection timing, tighten the fuel injection pump.

Note: Do not scratch the O-ring between the fuel injection pump and gear case.

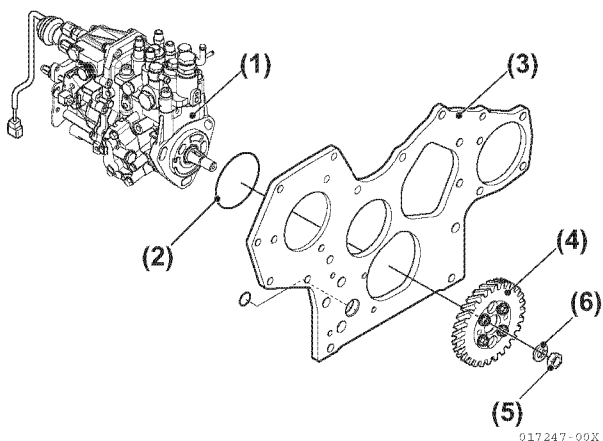

Figure 5-159

- 1 – Fuel Injection Pump
- 2 – O-ring
- 3 – Gear Case
- 4 – Fuel Injection Pump Drive Gear and Fuel Injection Pump Hub
- 5 – Pump Drive Gear Nut
- 6 – Washer

- Fit the fuel injection pump drive gear to the fuel pump camshaft.
- Align the “B” match marks on the fuel injection pump drive gear and idle gear (Figure 5-160).

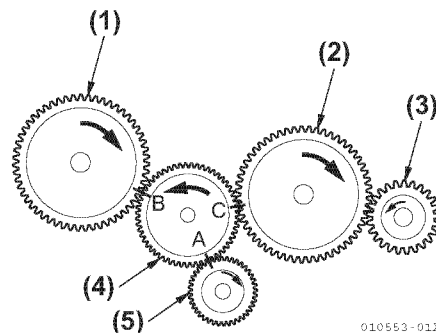

Figure 5-160

- 1 – Fuel Injection Pump Drive Gear
- 2 – Camshaft Gear
- 3 – Seawater Pump Gear
- 4 – Idle Gear
- 5 – Crankshaft Gear

- Tighten the pump drive gear nut, fastening the fuel pump gear and camshaft to the specified torque.

Tightening Torque of Pump Drive Gear Nut

3JH4E No Lubricating Oil	78.2-98.2 N·m (57.7-72.4 lb-ft)
4JH4AE No Lubricating Oil	34.3 ± 2.0 N·m (25.3 ± 1.5 lb-ft)

- Measure the backlash between the fuel injection pump drive gear and idle gear.

Backlash

Fuel Injection Pump Drive Gear	0.07-0.15 mm (0.003-0.006 in.)
--------------------------------	-----------------------------------

38. 4JH4-TE and 4JH4-HTE: Install the fuel injection pump.

- Install the VE pump bracket and O-ring to the gear case while adjusting both mark-off lines of the bracket and gear case (**Figure 5-161**).

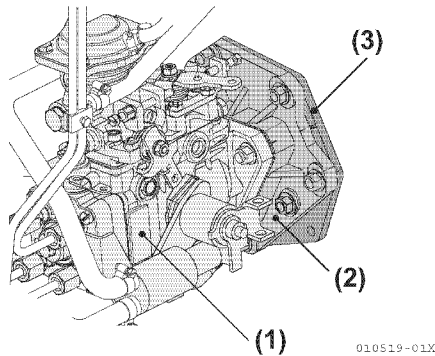

Figure 5-161

- 1 – VE Pump
- 2 – VE Pump Bracket
- 3 – Gear Case

- Install the fuel injection pump and O-ring to the VE pump bracket while adjusting both mark-off lines on the bracket with the VE pump. Lightly tighten the 3 nuts. After adjusting injection timing, tighten the fuel injection pump.

Note: Be careful not to scratch the O-ring between the fuel injection pump and bracket.

- Fit the pump drive gear to the pump camshaft (**Figure 5-162**).

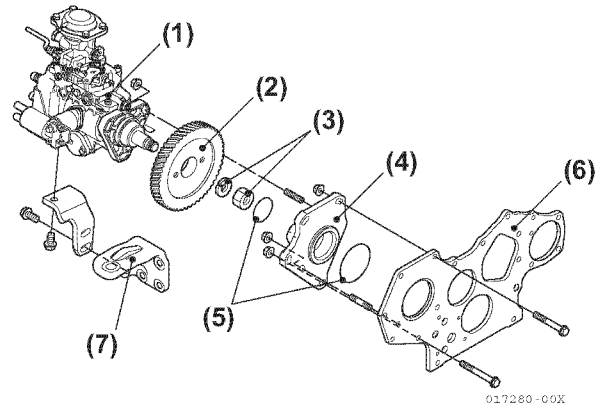

Figure 5-162

- 1 – Fuel Injection VE Pump
- 2 – Fuel Injection VE Pump Drive Gear
- 3 – Drive Gear Nut and Washer
- 4 – VE Pump Bracket
- 5 – O-Ring
- 6 – Gear Case
- 7 – VE Pump Support

- Align the “B” match marks on the pump drive gear and idle gear.
- After applying lubricating oil to the nut, tighten it to the specified torque.

Tightening Torque

4JH4-TE, 4JH4-HTE Coat with Lubricating Oil	59-69 N·m (44-51 lb-ft)
--	----------------------------

- Measure the backlash between the pump drive gear and idle gear.

Backlash	0.07-0.15 mm (0.003-0.006 in.)
----------	-----------------------------------

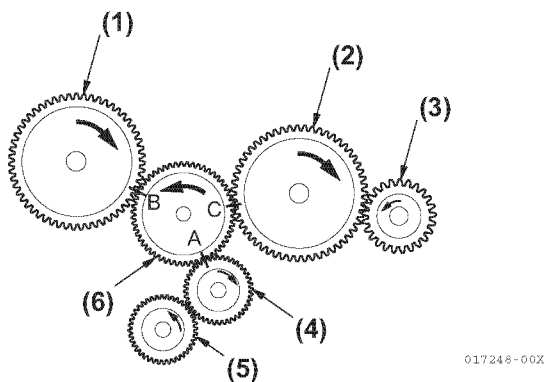

Figure 5-163

- 1 – Fuel Injection VE Pump Drive Gear
- 2 – Camshaft Gear
- 3 – Seawater Pump Gear
- 4 – Crankshaft Gear
- 5 – Lubricating Oil Pump Gear
- 6 – Idle Gear

- Install the VE pump supports (Figure 5-164, (7)).

4JH4-TE and 4JH4-HTE Engines Shown

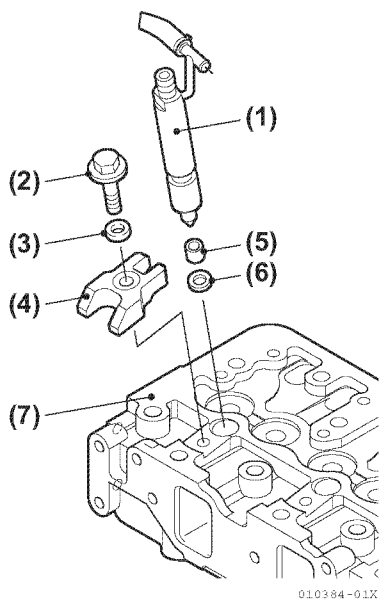

Figure 5-164

- 1 – Fuel Injection Nozzle
- 2 – Bolt
- 3 – Washer
- 4 – Fuel Nozzle Retainer
- 5 – Fuel Nozzle Protector
- 6 – Fuel Injection Seat
- 7 – Cylinder Head

39. Install the fuel injection nozzle:

- Replace the used fuel nozzle protector and fuel nozzle seat. Put the seat in the cylinder head and the protector on the nozzle tip. Install the fuel injection nozzle to the cylinder head.
NOTICE: In the case of a 4-valve cylinder head, the fuel inlet of the fuel nozzle must align with the pipe seal, which is installed to the rocker arm cover. Replace the used pipe seal with new one.

4JH4-TE and 4JH4-HTE Engines Shown

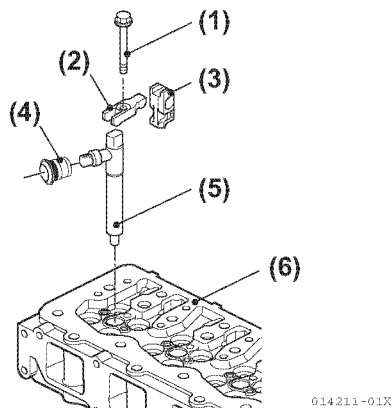

Figure 5-165

- 1 – Fuel Injection Nozzle
- 2 – Bolt
- 3 – Retainer
- 4 – Line Seal
- 5 – Fuel Injection Nozzle
- 6 – Cylinder Head

- Tighten the fuel nozzle retainer bolt to the specified torque. Do not apply lubricating oil to the bolt.

Tightening Torque of Fuel Nozzle Retainer Bolt

3JH4, 4JH4-TE and 4JH4-HTE	24.4-28.4 N·m (18-21 lb-ft.)
4JH4AE	26.4 ± 2.0 N·m (19.5 ± 1.5 lb-ft)

40. Install the freshwater pump:

- Thoroughly coat both sides of the gasket with adhesive.
- Replace the O-ring for the connecting part of the pump, which is inserted in the cylinder block, and tighten the freshwater pump to the specified torque (Figure 5-166).

Tightening torque

Freshwater pump	6.9 -11 N·m (5.1 -8.1 lb-ft.)
-----------------	----------------------------------

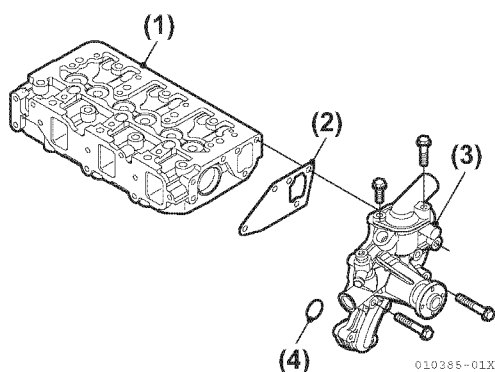
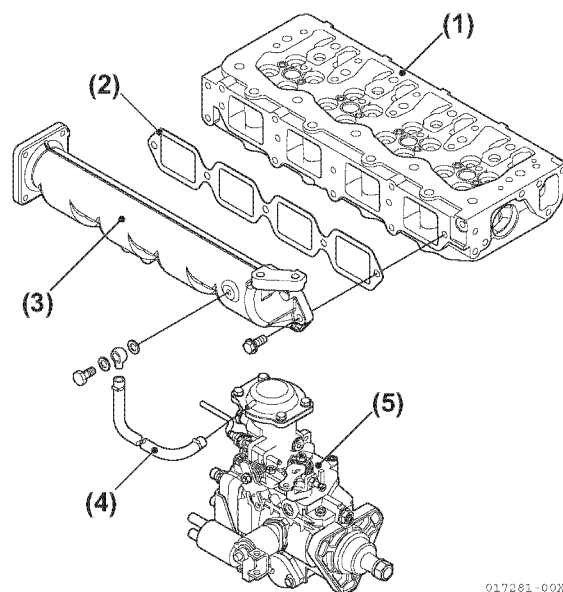

Figure 5-166

- 1 – Cylinder Head
- 2 – Gasket
- 3 – Freshwater Pump
- 4 – O-Ring

41. Thoroughly clean the inside of the intake manifold. Install the gasket and intake manifold (Figure 5-167).



017281-00X

Figure 5-167

- 1 – Cylinder Head
- 2 – Gasket
- 3 – Intake Manifold
- 4 – B.C.S Line of VE Pump
- 5 – VE Pump

Note: Connect the B.C.S line to the VE Pump and intake manifold for the 4JH4-TE and 4JH4-HTE.

42. Install the fuel injection line and then assemble the fuel injection line retainer to prevent line vibration.

Note: Lightly tighten the line joint nuts on both ends of the fuel injection line. Completely tighten after adjusting the injection timing.

Standard Tightening Torque

Fuel Injection Line Joint Nut	29.4-34.4 N·m (21.7-25.4 lb-ft)
-------------------------------	------------------------------------

43. Mount the fuel return line (Figure 5-168), (Figure 5-169) and (Figure 5-170).

3JH4E Engine

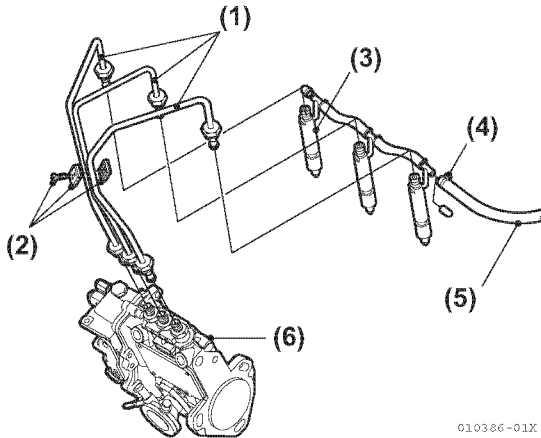

Figure 5-168

- 1 – Fuel Injection Line
- 2 – Fuel Injection Line Retainer
- 3 – Fuel Injection Nozzle
- 4 – Clamp
- 5 – Fuel Return Line
- 6 – Fuel Injection Pump

4JH4AE Engine

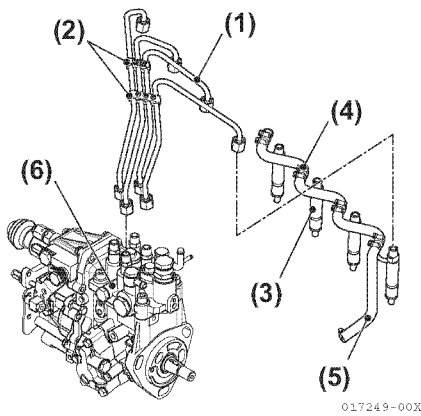

Figure 5-169

- 1 – Fuel Injection Line
- 2 – Fuel Injection Line Retainer
- 3 – Fuel Injection Nozzle
- 4 – Clamp
- 5 – Fuel Return Line
- 6 – Fuel Injection Pump

4JH4-TE and 4JH4-HTE Engines

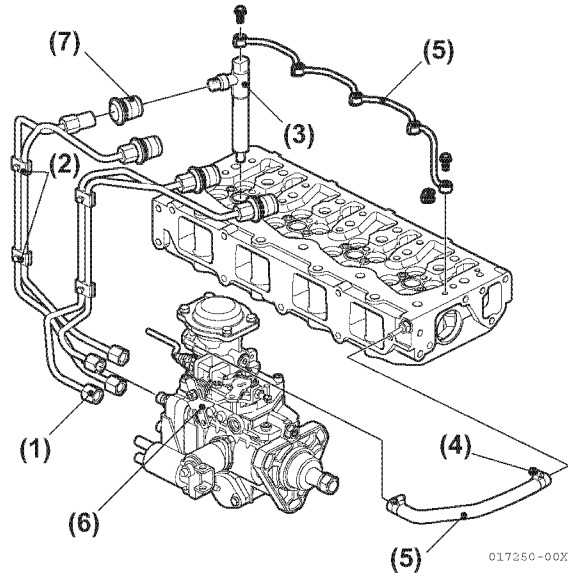

Figure 5-170

- 1 – Fuel Injection Line
- 2 – Fuel Injection Line Retainer
- 3 – Fuel Injection Nozzle
- 4 – Clamp
- 5 – Fuel Return Line
- 6 – Fuel Injection Pump
- 7 – Line Seal

44. Install the filter bracket and gasket on the cylinder block (Figure 5-171).

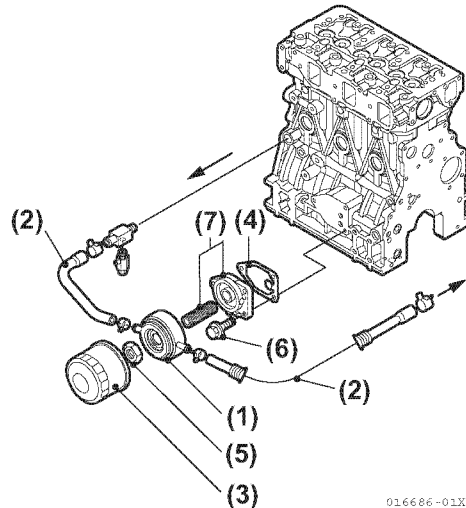

Figure 5-171

- 1 – Lubricating Oil Cooler
- 2 – Freshwater Lines
- 3 – Lubricating Oil Filter
- 4 – Gasket
- 5 – Lubricating Oil Cooler Nut
- 6 – Bolt for Filter Bracket
- 7 – Filter Bracket

45. Install the lubricating oil cooler to the filter bracket. Tighten the lubricating oil cooler nut (Figure 5-171).
46. Install the freshwater pipes; (cylinder block, lubricating oil cooler, lubricating oil cooler, freshwater pump (Figure 5-171).
47. Install the lubricating oil filter with the filter case remover tool (Figure 5-171).
48. Install the seawater pump assembly and gasket to the gear case (Figure 5-172) and (Figure 5-173).

4JH4-TE and 4JH4-HTE Engines

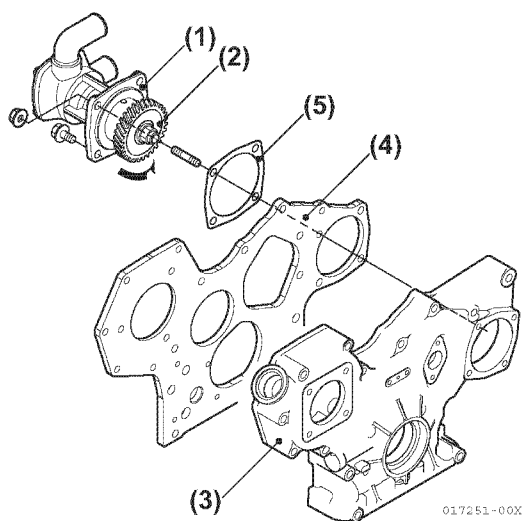

Figure 5-172

- 1 – Seawater Pump
- 2 – Pump Drive Gear
- 3 – Gear Case
- 4 – Gear Case Flange
- 5 – Gasket

3JH4E and 4JH4AE Engines

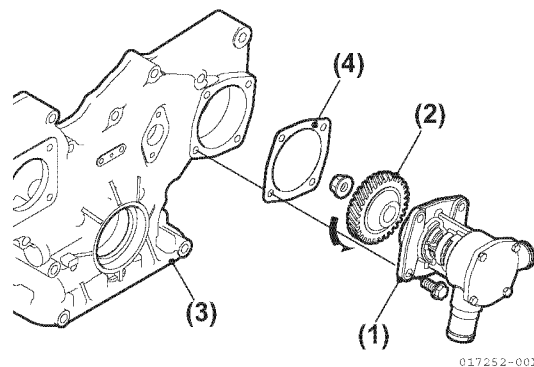

Figure 5-173

- 1 – Seawater Pump
- 2 – Pump Drive Gear
- 3 – Gear Case Cover
- 4 – Gasket

49. Lightly tap the gear case side bearing rest with a wood hammer, and tighten the bolts.

50. Attach the noise absorber to the rocker arm cover before assembling the heat exchanger for 4JH4AE (**Figure 5-174, (1)**), 4JH4-TE and 4JH4-HTE (**Figure 5-175, (1)**).

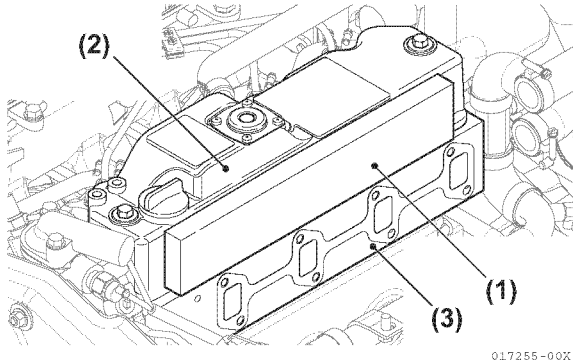

Figure 5-174

- 1 – Noise Absorber
- 2 – Heat Exchanger
- 3 – Cylinder Head

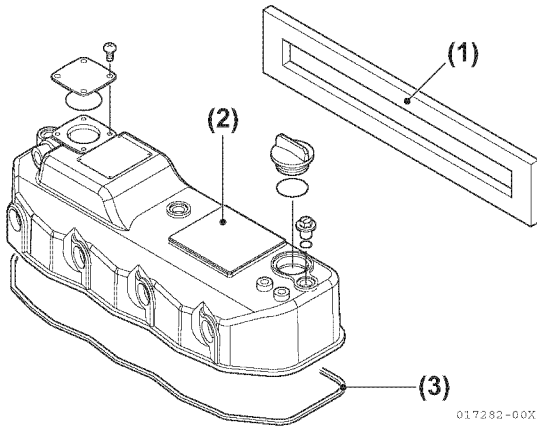

Figure 5-175

- 1 – Noise Absorber
- 2 – Heat Exchanger
- 3 – Gasket

51. Install the gasket and heat exchanger (exhaust manifold) to the cylinder head.

52. Install the coolant pipes (seawater / freshwater):

- For 3JH4 install the seawater pipes with the hose clips (**Figure 5-176**).

Seawater Lines of 3JH4 Shown

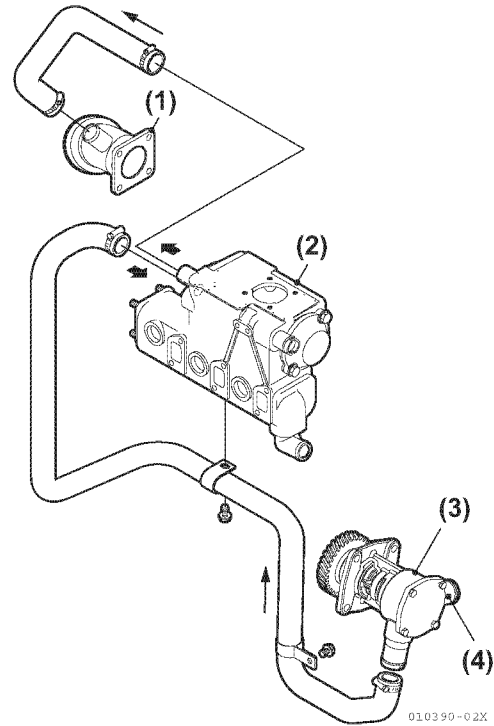

Figure 5-176

- 1 – Mixing Elbow
- 2 – Heat Exchanger
- 3 – Seawater Pump
- 4 – Seawater Inlet

- For 4JH4AE gear case side seawater pipe, insert the pipe in the retainer. Fasten the retainer to the mounting foot with flange bolt (Figure 5-177).

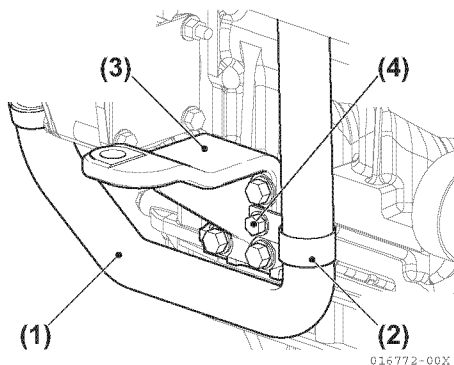

Figure 5-177

- 1 – Seawater Pipe
- 2 – Retainer
- 3 – Flange Bolt
- 4 – Mounting Foot

- For 4JH4AE flywheel housing side seawater pipe, fasten the retainer together with the ground terminal to the flywheel housing by the ground bolt for sail drive and ZF30M (Figure 5-178).

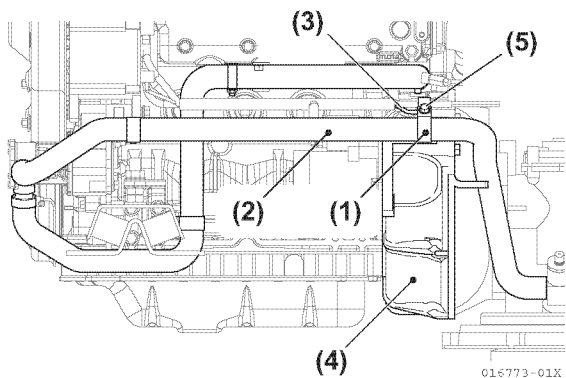

Figure 5-178

- 1 – Retainer
- 2 – Seawater Pipe
- 3 – Ground Terminal
- 4 – Flywheel Housing
- 5 – Ground Bolt

- When the 4JH4AE is coupled with SD50 For gear case side seawater pipe, fasten the upper side bolt with the bracket. Clamp the pipe with the retainer and attach to bracket (Figure 5-179).

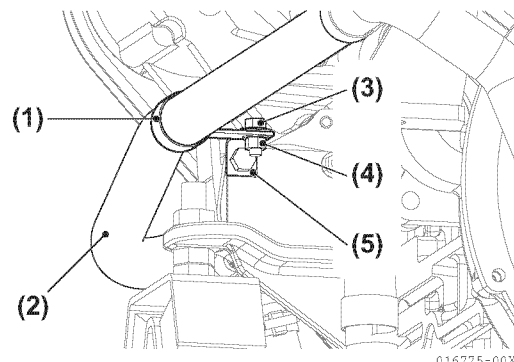

Figure 5-179

- 1 – Retainer
- 2 – Gear Case Side Seawater Pipe
- 3 – Bolt
- 4 – Nut
- 5 – Bracket

- Figure 5-180 shows Seawater Pipes for 4JH4AE with ZF30D (typical).

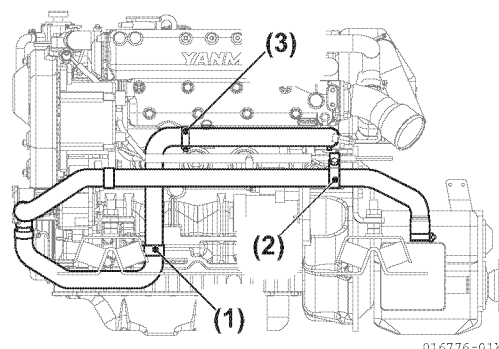

Figure 5-180

- 1 – Retainer
- 2 – Retainer
- 3 – Retainer

- In case of the SD50, the method is the same (Figure 5-181).

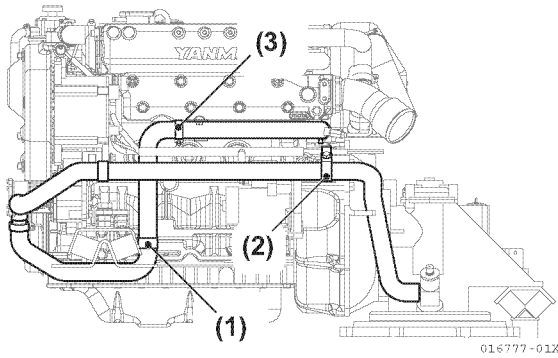

Figure 5-181

- 1 – Retainer**
- 2 – Retainer**
- 3 – Retainer**

- When 4JH4AE is coupled with KM4A1, seawater pipes for KM4A1 marine gear cooler are shown in (Figure 5-182) and (Figure 5-183).

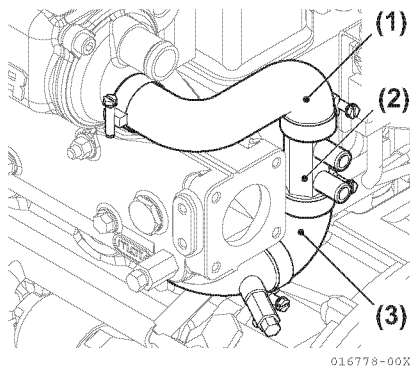

Figure 5-182

- 1 – Seawater pipe to Heat Exchanger Inlet from Seawater Pump**
- 2 – Joint**
- 3 – Seawater Pipe from Seawater Pump**

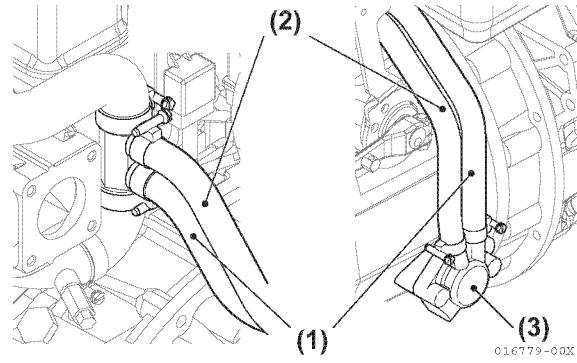

Figure 5-183

- 1 – Seawater pipe to Marine Gear (KM4A1) Oil Cooler**
- 2 – Seawater pipe from Marine Gear (KM4A1) Oil Cooler**
- 3 – Marine gear Oil Cooler**

- Install the freshwater pipes with the hose clips; exhaust manifold, freshwater pump, freshwater pump heat exchanger.
- Install the freshwater pipes; cylinder block, lubricating oil cooler, lubricating oil cooler, freshwater pump.

Freshwater Lines of 3JH4 Shown

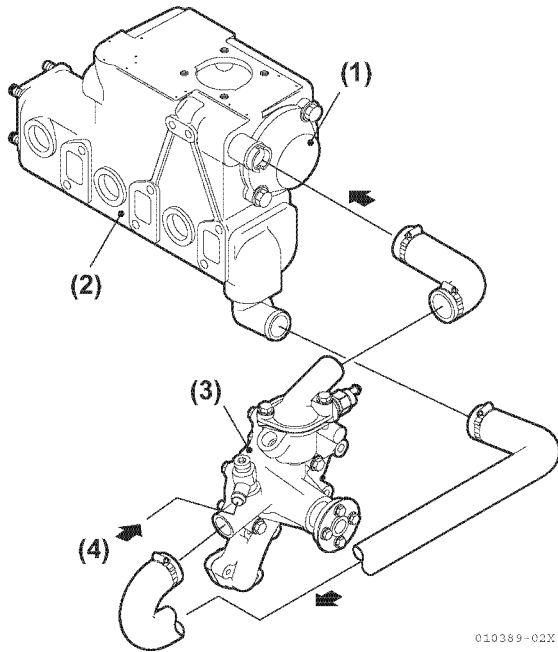

Figure 5-184

- 1 – Heat Exchanger
- 2 – Exhaust Manifold
- 3 – Freshwater Pump
- 4 – From Lubricating Oil Cooler

- Install the freshwater pipe; lubricating oil cooler, freshwater pump. Attach the pipe to the bracket of the feed pump by nylon band (Figure 5-185).

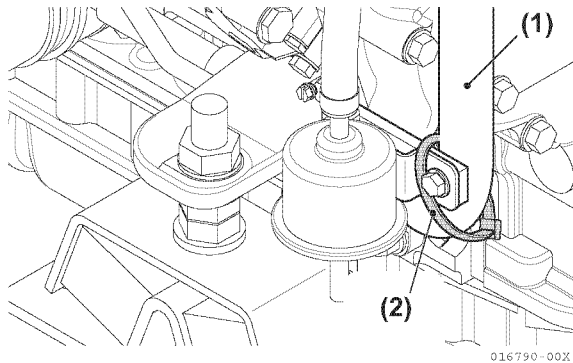

Figure 5-185

- 1 – Freshwater Pipe To Oil Cooler
- 2 – Nylon Band

- Attach the feed pump wire harness to the oil cooler water pipe by nylon band (for 4JH4AE only) (Figure 5-186).

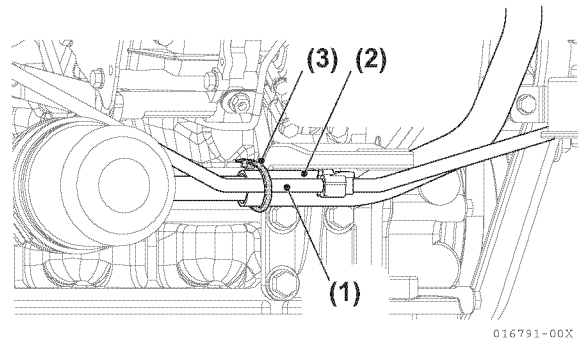

Figure 5-186

- 1 – Feed Pump Wire Harness
- 2 – Oil Cooler Water Pipe
- 3 – Nylon Band

53. Install the alternator:

Note: Connect the wires to the terminals before attaching the alternator to the gear case (Figure 5-187).

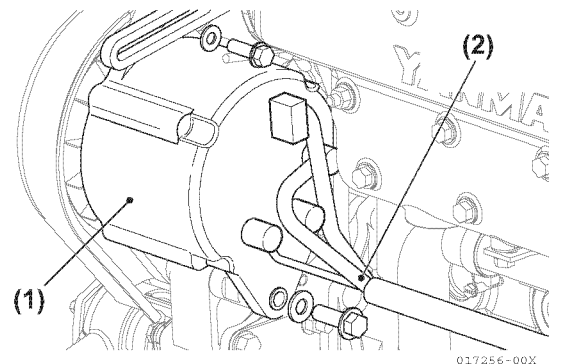

Figure 5-187

- 1 – Alternator
- 2 – Wires and Terminals

- Install the adjuster on the freshwater pump, the distance piece on the gear case, and then the alternator.

- Adjust V-belt tension with the adjuster, and tighten the mounting bolts (**Figure 5-188**).

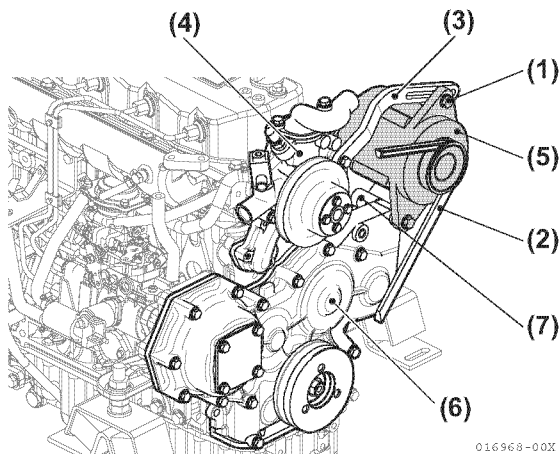

Figure 5-188

- 1 – Alternator Adjust Bolt**
- 2 – V-belt**
- 3 – Adjuster**
- 4 – Freshwater Pump**
- 5 – Alternator**
- 6 – Gear Case**

54. Install the V-belt cover.

- Install the water pump adjustment bolt.
- Insert insulation rubbers and collars to the hole of belt cover.
- Fasten the belt cover to the bolts with washers by nuts.

4JH4AE Engine Shown

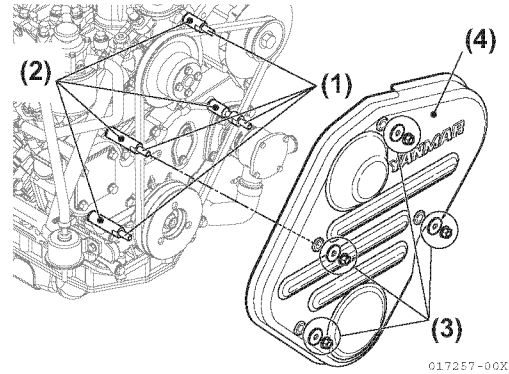

Figure 5-189

- 1 – Bolt**
- 2 – Insulation Rubber and Collar**
- 3 – Washer and Nut**
- 4 – V-belt Cover**

55. Install the starting motor in the flywheel housing (**Figure 5-190**).

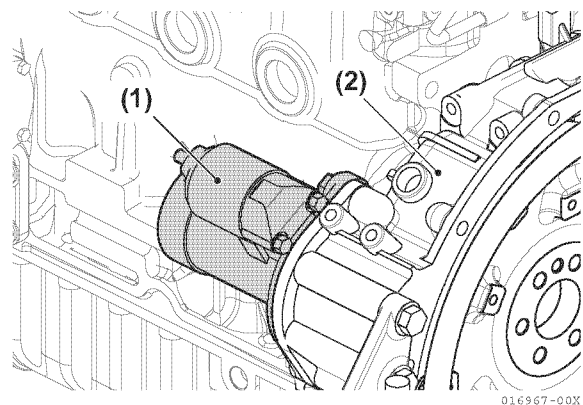

Figure 5-190

- 1 – Starting Motor**
- 2 – Flywheel Housing**

56. Install the starter relay, stop solenoid relay and air heater relay by flange bolts. Connect the harness to each relays.

4JH4AE Engine Shown

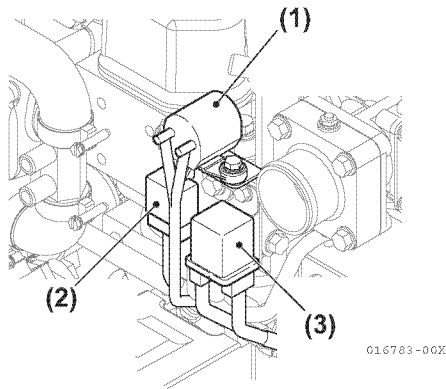

Figure 5-191

- 1 – Starter Relay
- 2 – Stop Solenoid Relay
- 3 – Air Heater Relay

Note: Fasten the clamp of wire harness to upside, to avoid the interference to the mounting foot (Figure 5-192).

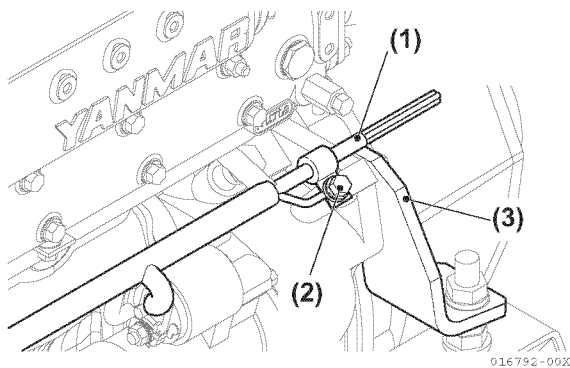

Figure 5-192

- 1 – Wire Harness
- 2 – Clamp
- 3 – Mounting Foot

57. 4JH4-HTE: Install the inter cooler.

- Install the seawater pipes with the hose clips.
- Install the air duct from the inter cooler to the intake manifold.
- Install the air duct from the turbocharger to the inter cooler (Figure 5-193).

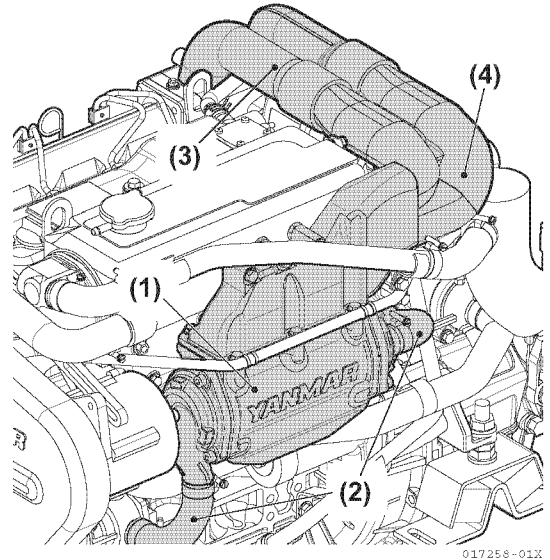

Figure 5-193

- 1 – Inter Cooler
- 2 – Seawater Pipe
- 3 – Air Duct to Intake Manifold
- 4 – Air Duct from Turbocharger

58. Install the turbocharger for 4JH4-TE and 4JH4-HTE (Figure 5-194).

- Install the turbocharger to the exhaust manifold.
- Install the lubricating oil pipe and the freshwater pipe to the turbocharger.

4JH4-TE Engine Shown

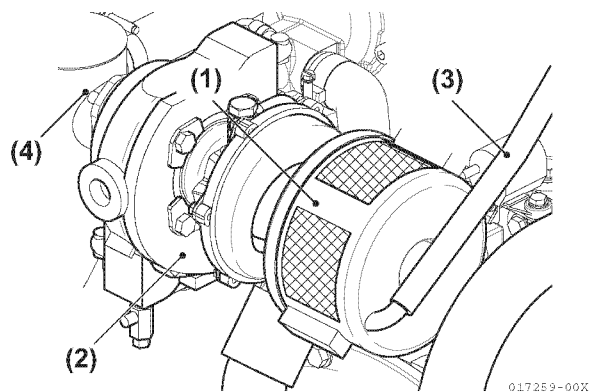

Figure 5-194

- 1 – Intake Silencer**
- 2 – Turbocharger**
- 3 – Lubricating Oil Pipe**
- 4 – Mixing Elbow**

59. Install the mixing elbow on the exhaust manifold outlet for 3JH4E and 4JH4AE and on the turbocharger for 4JH4-TE and 4JH4-HTE.
60. Install the cooling seawater pipe (rubber hose) with the hose clips (heat exchanger-mixing elbow).
61. Install the intake silencer on the intake manifold inlet coupling for 3JH4E and 4JH4-AE and on the turbocharger for 4JH4-TE and 4JH4-HTE.
62. Install the breather hose to the silencer with the hose clips (intake silencer- rocker arm cover).
63. Install suction air silencer of 3JH4E and 4JH4-AE.
64. Install the bracket on the flywheel housing by bolt and mount the suction pipe to the silencer.

3JH4E and 4JH4AE Engines Shown

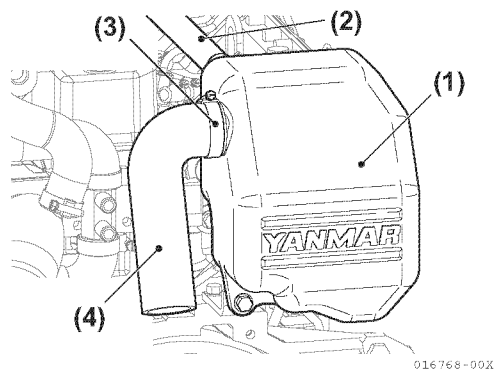

Figure 5-195

- 1 – Suction Air Silencer**
- 2 – Breather Hose**
- 3 – Hose Band**
- 4 – Suction Pipe**

65. Secure the silencer to the suction manifold with rubber pipe and horse band (**Figure 5-196**).

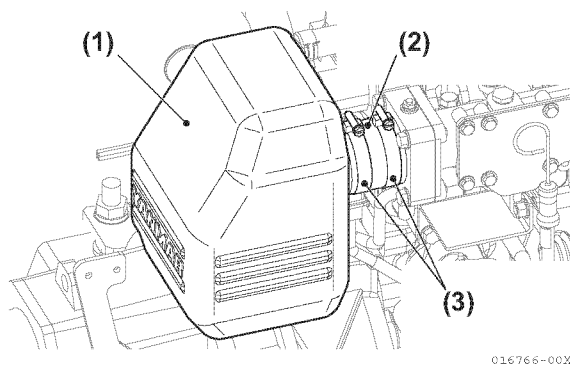

Figure 5-196

- 1 – Silencer**
- 2 – Rubber pipe**
- 3 – Hose Band**

66. Insert the collar into the hole of silencer and fix to the bracket by bolt (Figure 5-197).

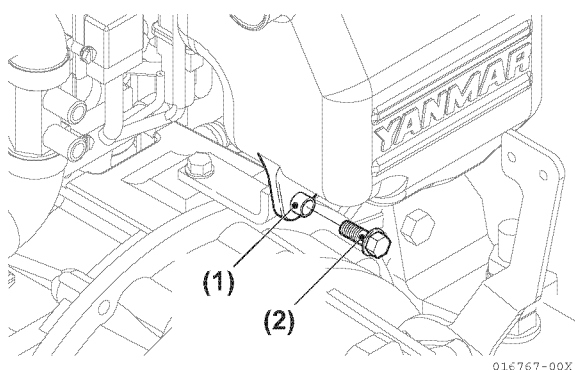

Figure 5-197

- 1 – Collar
- 2 – Bolt

67. Secure the intake pipe with a hose clamp.

68. Install the fuel filter bracket on the intake manifold (Figure 5-198).

4JH4AE Filter and Bracket Shown

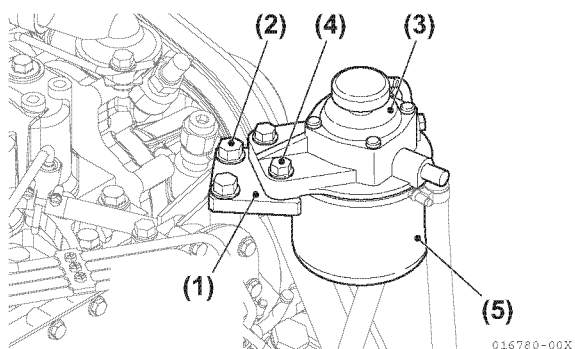

Figure 5-198

- 1 – Fuel Filter Bracket
- 2 – Bolt
- 3 – Priming Pump
- 4 – Bolt
- 5 – Fuel Filter

69. Install the fuel filter (Figure 5-198).

70. Install the fuel feed pump and bracket (Figure 5-199). Install the bracket and the fuel feed pump to the cylinder block by bolt.

4JH4AE Engine Shown

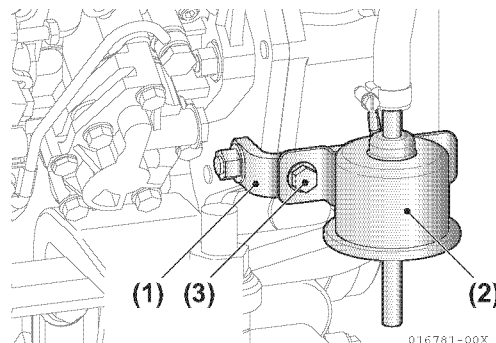

Figure 5-199

- 1 – Bracket
- 2 – Electric Fuel Feed Pump
- 3 – Bolt

71. Install the fuel pipe (fuel feed pump-fuel filter, fuel filter-fuel injection pump) (Figure 5-200).

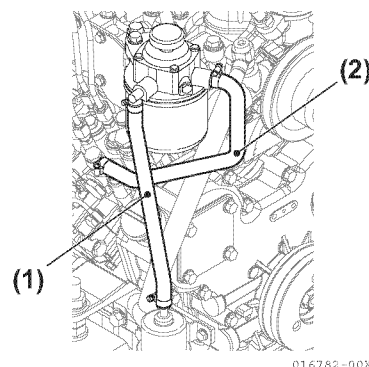

Figure 5-200

- 1 – Fuel Line (Fuel Feed Pump - Fuel Filter)
- 2 – Fuel Line (Fuel Filter - Fuel Injection Pump)

72. Connect the electric wiring to the proper terminals, observing the color coding to make sure the connections are correct. Clamp the wire harness by fastening the clamp to upside, to avoid the interference to the mounting foot (Figure 5-201).

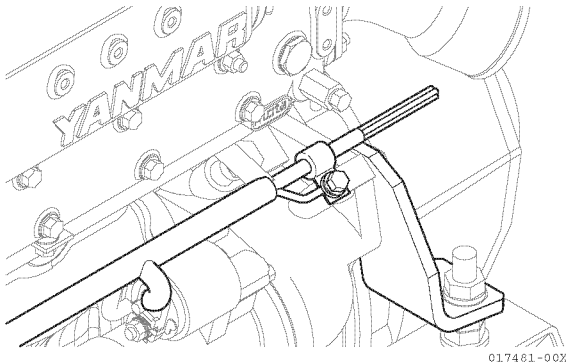

Figure 5-201

73. Connect the electric wires to the terminals before attaching the alternator to the gear case (Figure 5-202).

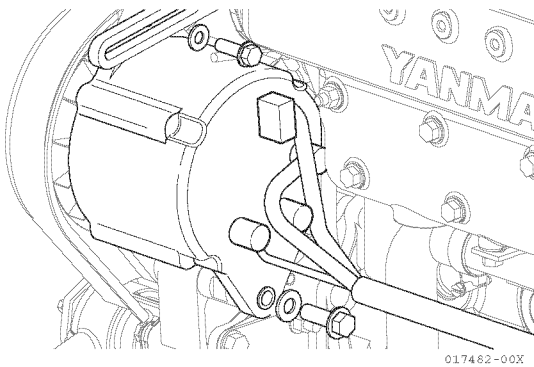

Figure 5-202

74. Installation in a boat and completion of the piping and wiring:

- Mount the engine on the engine bed in the engine room of a boat after all engine assembly has been completed.
- Connect the coolant pipes, fuel pipes, other pipes on the boat and the exhaust hoses.
- Connect the battery, instrument panel, remote control cable and other wiring.

75. Fill the engine with lubricating oil from the supply port on top of the gear case or the rocker arm cover and fill the marine gearbox from the supply port on top of the reduction gear case. (Figure 5-203) and (Figure 5-204).

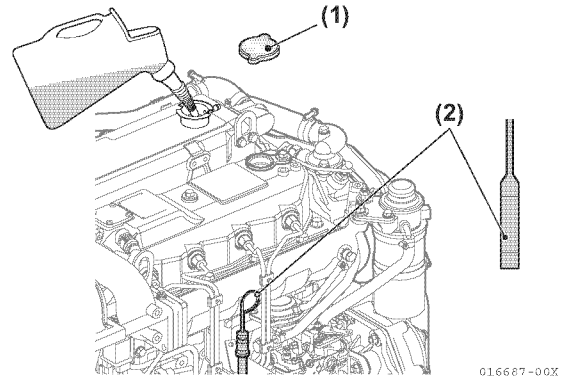

Figure 5-203

**1 – Supply Port
2 – Dipstick**

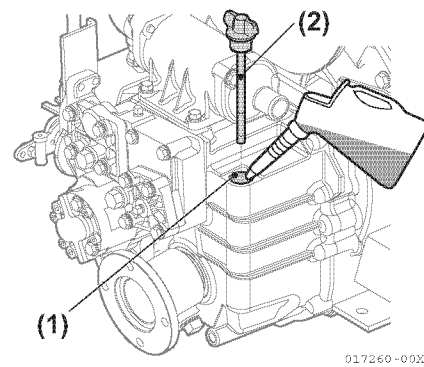

Figure 5-204

**1 – Supply Port
2 – Dipstick**

76. Remove the coolant (freshwater) tank filler cap and fill tank with water.

3JH4E	4.5 L (4.8 qt)
4JH4AE	6.0 L (6.3 qt)
4JH4-TE/ 4JH4-HTE	7.2 L (7.6 qt)

77. Fill with water in the coolant recovery tank until the level is between the full and low marks **(Figure 5-205)**.

Coolant Recovery Tank Capacity (Full)	0.8 L (0.85 qt)
---------------------------------------	-----------------

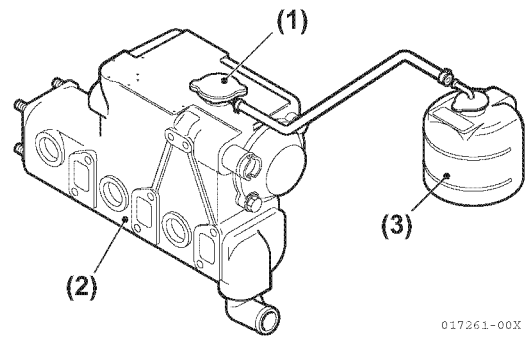

Figure 5-205

- 1 – Filler Cap**
- 2 – Coolant Tank**
- 3 – Coolant Recovery Tank**

78. Check fuel injection timing . See *Checking and Adjusting Fuel Injection Timing* on page 6-58.

Check and Adjust the Remote Control Operation

The various control levers on the engine side are connected to the remote control lever by the remote control cable. The cable will become stretched and the attachments loose after long hours of use causing deviation. It is dangerous to control operation under these conditions, and the remote control cable must be checked and adjusted periodically.

- Adjusting the throttle remote control cable. Check to see that the control lever on the engine side moves to the high speed stop position and low speed stop position when the remote control lever is moved to H (high speed) and L (low speed) respectively.

When there is deviation, loosen the bracket for the remote control cable on the engine side and adjust.

Adjust the high speed stop position first and then adjust the low speed idling by the adjustment bolt on the remote control lever. **CAUTION! Never adjust the high speed limiting bolt. This will void warranty.**

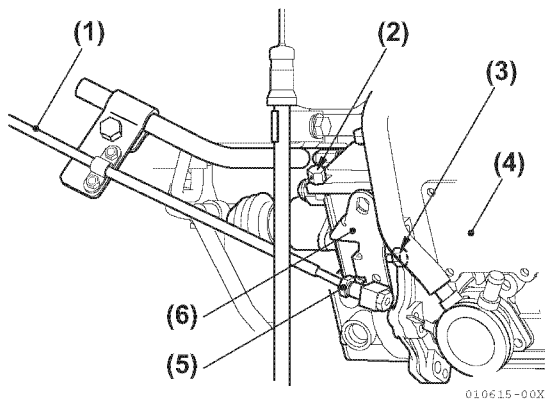

Figure 5-206

- 1 – Remote Control Cable
- 2 – High Speed Limiting Bolt
- 3 – Low Speed Limiting Bolt
- 4 – Fuel Injection Pump
- 5 – Cable Joint
- 6 – Control lever

- Adjusting the marine gear remote control cable
Check that the shift lever moves to the correct position, when the remote control handle is put in NEUTRAL, FORWARD and REVERSE position. Use the NEUTRAL position as the standard for adjustment. When there is deviation, loosen the clamp for the remote control cable and adjust the shift lever position.

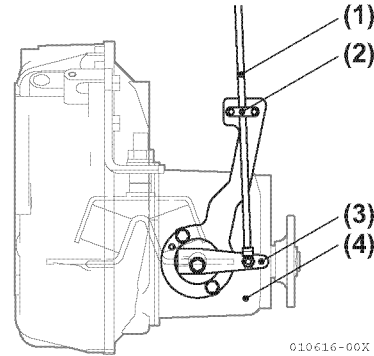

Figure 5-207

- 1 – Remote Control Cable
- 2 – Clamp
- 3 – Shaft Lever
- 4 – Marine gear

Section 6

FUEL SYSTEM

	Page
Safety Precautions	6-3
Introduction.....	6-3
Specifications	6-4
Test and Adjustment Specifications	6-4
Special Torque Chart.....	6-5
Special Service Tools.....	6-6
Fuel System Components	6-9
Fuel Flow Diagram	6-10
Fuel System Tests.....	6-12
Measure Fuel Feed Pump Pressure Procedure	6-12
Test Return Fuel Pressure	6-13
Fuel System Service	6-14
Fuel Injection Nozzle Removal	6-14
Cleaning Fuel Injection Nozzle Cavities	6-15
Fuel Injection Nozzle Installation	6-15
Fuel Injection Lines Removal	6-16
Fuel Injection Line Installation	6-17
Fuel Injection Pump Replacement.....	6-21
Adjust Fuel Injection Timing	6-23
Fuel Line Replacement Filter.....	6-36
Replace Injection Nozzle Return	6-39
Bleeding the Fuel System.....	6-40
MP Fuel Injection Pump System	6-41
Introduction.....	6-41
Fuel Injection Pump.....	6-41
Stop Solenoid	6-42
Trochoid Fuel Pump	6-42

FUEL SYSTEM

Fuel System Specifications	6-43
Special Torque Chart	6-43
Fuel Injection Pump Service Data	6-44
Test and Adjustment Specifications	6-45
Special Service Tools.....	6-46
Measuring Instruments.....	6-46
Fuel System Diagram.....	6-47
Fuel System Components	6-48
Fuel Injection Pump	6-49
Fuel Injection Pump Removal	6-49
Fuel Injection Pump Installation	6-53
Checking and Adjusting Fuel Injection Timing	6-58
Determining the Fuel Injection Timing Specification	6-58
Checking Fuel Injection Timing	6-59
Adjusting Fuel Injection Timing	6-62
Fuel Injectors.....	6-63
Fuel Injectors Removal.....	6-63
Fuel Injectors Testing.....	6-63
Fuel Injectors Disassembly and Inspection	6-64
Adjusting Fuel Injector Pressure	6-65
Fuel Injectors Reassembly.....	6-66

SAFETY PRECAUTIONS

Before you service the fuel system, read the following safety information and review the *Safety Section on page 2-1*.

WARNING

The safety messages that follow have **WARNING** level hazards. These safety messages describe a hazardous situation which, if not avoided, *could* result in death or serious injury.

Fire Hazard



Diesel fuel is flammable and explosive under certain conditions. NEVER put diesel fuel or other flammable material such as oil, hay or dried grass near the engine during engine operation or shortly after shutdown.

Never use a shop rag to catch the fuel.

ALWAYS put an approved fuel container under the opening whenever you remove any fuel system component (such as changing the fuel filter). Dispose of waste properly.

Wipe up all spills immediately.

High-Pressure Hazard



NEVER check for a fuel leak with your hands. ALWAYS use a piece of wood or cardboard.

INTRODUCTION

This section of the *Service Manual* describes the procedures necessary to remove, install, and repair fuel system components as used on the Yanmar 3JH4E 4JH4AE, 4JH4-TE and 4JH4-HTE engines.

The fuel injection pump of 4JH4AE is described in the last part of this section.

SPECIFICATIONS

Test and Adjustment Specifications

3JH4E (TM02 Pump)

Inspection Item	Specification Reference
High-Pressure Fuel Pump Pressure	13 MPa (1886 psi)
Fuel Feed Pump Pressure	20 kPa (2.9 psi)
Return Fuel Pressure	515 mm Aq (20.3 in. Aq)
Fuel Supply Restriction	1000 mm Aq (40 in. Aq)

4JH4AE (PM2 Pump)

Inspection Item	Specification Reference
High-Pressure Fuel Pump Pressure	20.1 MPa (2.9 psi)
Fuel Feed Pump Pressure	20 kPa (2.9 psi)
Return Fuel Pressure	20 kPa (2.9 psi)
Fuel Supply Restriction	400 mm Aq (16 in. Aq)

4JH4-TE (Bosh VE Pump)

Inspection Item	Specification Reference
High-Pressure Fuel Pump Pressure	21.6 MPa (3133 psi)
Fuel Feed Pump Pressure	20 kPa (2.9 psi)
Return Fuel Pressure	20 kPa (2.9 psi)
Fuel Supply Restriction	1000 mm Aq (40 in. Aq)
Timer advancing angle	1.5° / 1100-1600 minimum ⁻¹ (rpm) pump speed

4JH4-HTE (Bosh VE Pump)



Inspection Item	Specification Reference
High-Pressure Fuel Pump Pressure	21.6 MPa (3133 psi)
Fuel Feed Pump Pressure	20 kPa (2.9 psi)
Return Fuel Pressure	20 kPa (2.9 psi)
Fuel Supply Restriction Excluding Fuel Filter Loss Pressure	1000 mm Aq (40 in. Aq)
Timer advancing angle	2.6° / 1200-1600 minimum ⁻¹ (rpm) pump speed

Special Torque Chart

Component		Tightening Torque	Lubricating Oil Application (Thread Portion and Seat Surface)	Reference Page
Fuel Injection Nozzle Retaining Bolt		26 N·m (19.2 lb-ft)	Not Applied	<i>Install Fuel injection Nozzle. See Install the fuel injection nozzle: on page 5-100</i>
Fuel Injection Pump Drive Gear Nut	3JH4E and 4JH4AE	83 N·m (61 lb-ft)		<i>Install Fuel Injection Pump. See Fuel Injection Pump Installation on page 6-53</i>
	4JH4-TE and 4JH4-HTE	64 N·m (47 lb-ft)		
Fuel Injection Line Joint Nut		32 N·m (24 lb-ft)	<i>Remove and Install Fuel Injection Lines. See Remove the fuel injection line (Figure 5-32) thru (Figure 5-34): on page 5-40</i>	

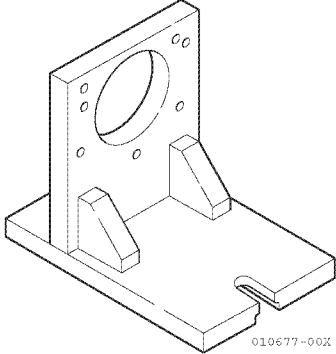
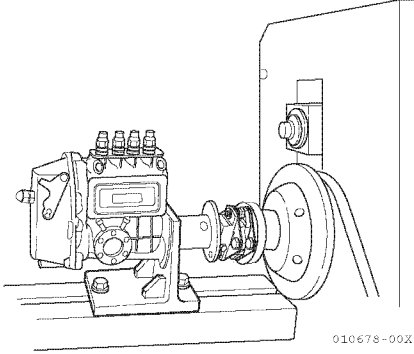
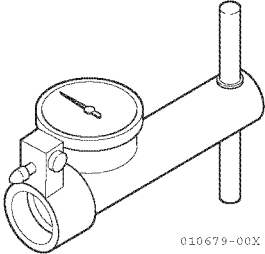
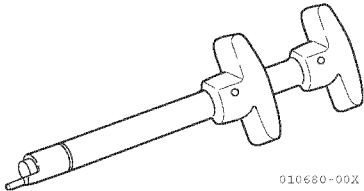
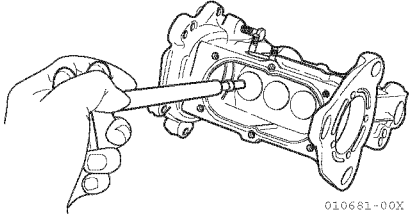
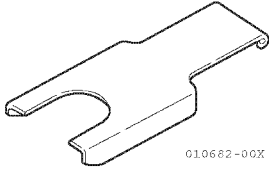
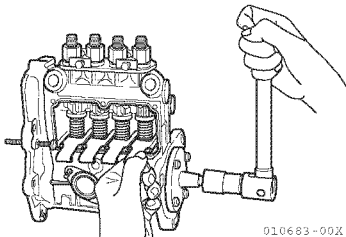
SPECIAL SERVICE TOOLS

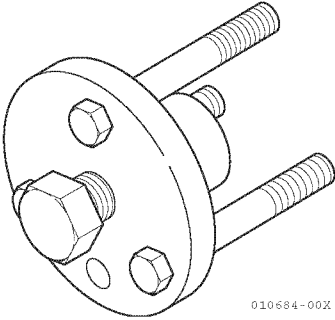
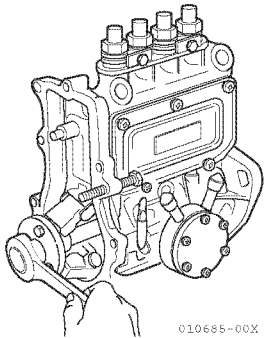
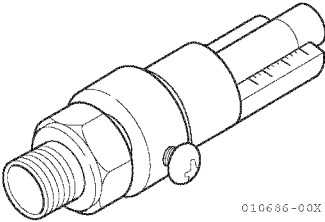
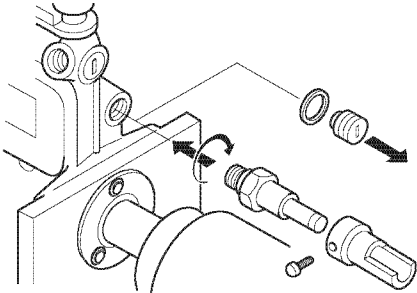
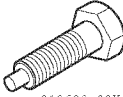
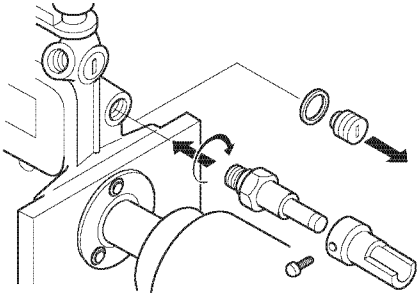
Name of Tool	Shape and Size	Application
Pump Mounting Scale for Yanmar Tester 158090-51010 for Bosch (Tester) 158090-51020	 <p>010677-00X</p>	 <p>010678-00X</p>
Measuring Device (Cam Backlash) 158090-51050	 <p>010679-00X</p>	
Plunger Insert 158090-51100	 <p>010680-00X</p>	 <p>010681-00X</p>
Tappet Holder 158090-51200	 <p>010682-00X</p>	 <p>010683-00X</p>

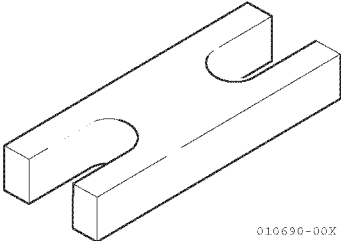
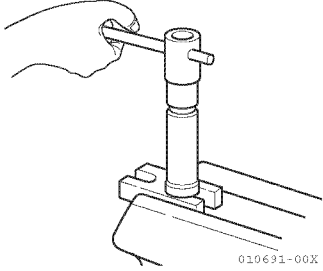
Name of Tool	Shape and Size	Application
Weight Extractor 158090-51400	 <p style="text-align: right;">010684-00X</p>	 <p style="text-align: right;">010685-00X</p>
Rack Indicator 158090-51500	 <p style="text-align: right;">010686-00X</p>	 <p style="text-align: right;">010688-00X</p>
Rack Lock Bolt 158090-51510	 <p style="text-align: right;">010689-00X</p>	 <p style="text-align: right;">010688-00X</p>
Dummy Nut 158090-51520	 <p style="text-align: right;">010687-00X</p>	
Nozzle Plate 158090-51700	 <p style="text-align: right;">010690-00X</p>	 <p style="text-align: right;">010691-00X</p>

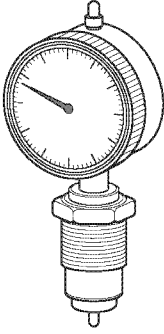
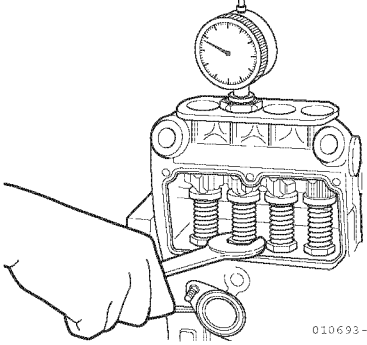
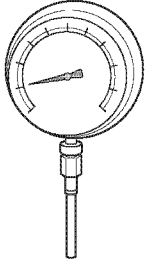
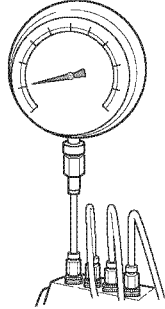
Name of Tool	Shape and Size	Application
Plunger Gauge 121820-92540	 <p style="text-align: center;">010692-00X</p>	 <p style="text-align: right;">010693-00X</p>
Top Clearance Gauge 158090-51300	 <p style="text-align: center;">010694-00X</p>	 <p style="text-align: right;">010695-00X</p>

FUEL SYSTEM COMPONENTS

3JH4E Engine

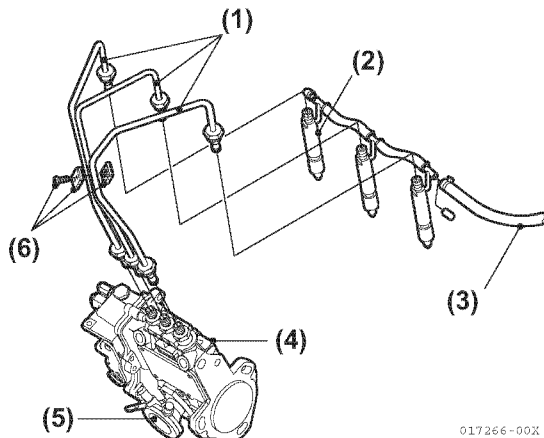

Figure 6-1

- 1 – Fuel Injection Line
- 2 – Fuel Injection Nozzle
- 3 – Fuel Return Line
- 4 – Fuel Injection Pump
- 5 – Fuel Feed Pump
- 6 – Fuel Injection Line Retainer

4JH4AE Engine

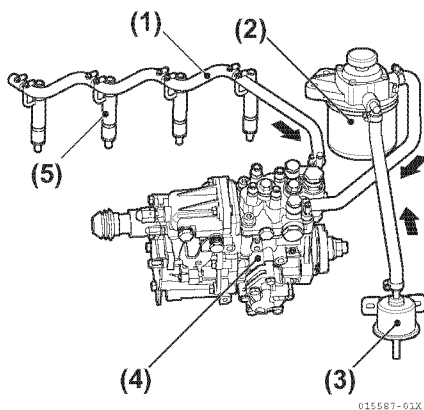

Figure 6-2

- 1 – Fuel Return Line
- 2 – Fuel Filter
- 3 – Electric fuel feed pump
- 4 – Fuel Injection Pump
- 5 – Fuel Injection Nozzle

4JH4E-HT/4JH4-HTE Engines

Note: 4JH4-HTE Fuel system components are shown. 4JH4-TE is similar.

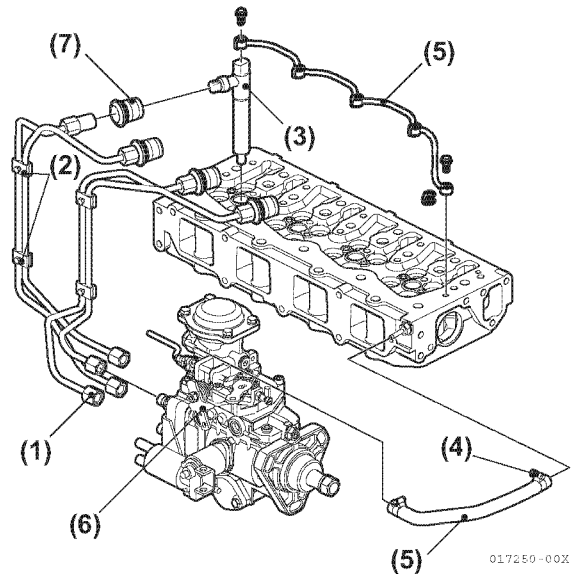

Figure 6-3

- 1 – Fuel Injection Line
- 2 – Fuel Injection Line Retainer
- 3 – Fuel Injection Nozzle
- 4 – Clamp
- 5 – Fuel Return Line
- 6 – Fuel Injection Pump
- 7 – Line Seal

FUEL FLOW DIAGRAM

Note: 3JH4E system shown.

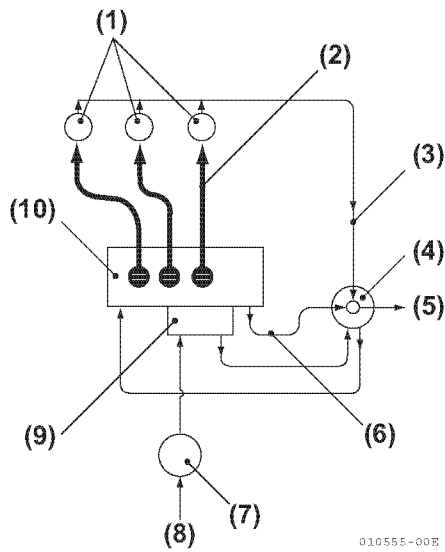
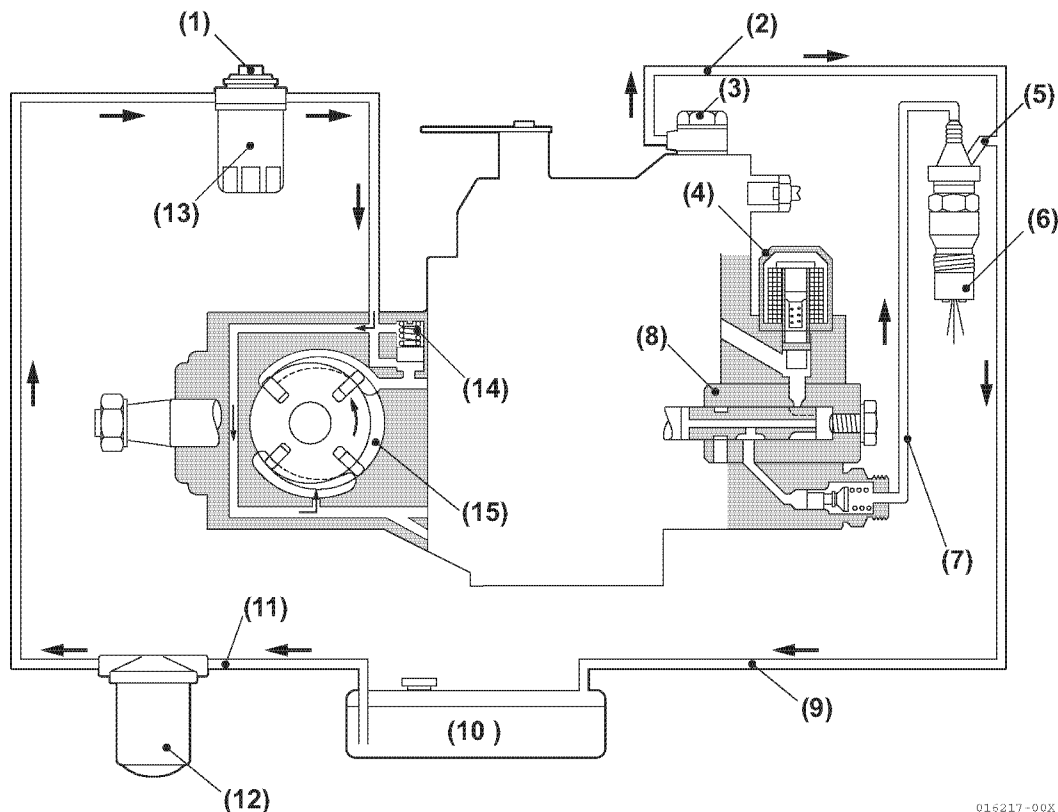

Figure 6-4

- 1 – Fuel Injection Nozzle
- 2 – Fuel Injection Lines
- 3 – Fuel Return Line
- 4 – Fuel Fine Filter (3 micron)
- 5 – Return Fuel to Fuel Tank
- 6 – Fuel Injection Pump Return Line
- 7 – Fuel Filter / Water Separator (10 micron for 3JH4E)
- 8 – Fuel Inlet from Tank
- 9 – Fuel Feed Pump
- 10 – Fuel Injection Pump

Note: 4JH4-TE system shown. 4JH4-HTE is similar.



016217-00X

Figure 6-5

- | | |
|---------------------------------------|-----------------------------|
| 1 – Fuel Priming Pump | 9 – Fuel Return Line |
| 2 – Return Fuel to Fuel Tank | 10 – Fuel Tank |
| 3 – Over Flow Valve | 11 – Fuel Injection Pump |
| 4 – Magnetic Valve | 12 – Fuel / Water Separator |
| 5 – Fuel Injection Nozzle Return Line | 13 – Fuel Filter |
| 6 – Fuel Injection Nozzle | 14 – Regulating Valve |
| 7 – High-Pressure Fuel Supply Line | 15 – Fuel Feed Pump |
| 8 – Plunger Barrel | |

FUEL SYSTEM TESTS

NOTICE: After completing work that involves opening the fuel system do the following:

- Bleed the system. See *Bleeding the Fuel System* on page 6-40.
- Start engine and check for leaks. Allow engine to run until it is running smoothly.
- Check and delete any trouble codes that are registered in the ECU after the work has been completed.

Measure Fuel Feed Pump Pressure

Procedure

1. Attach a suitable fuel pressure gauge to a tee joint, and connect a short length of hose to one of the remaining two legs of the tee (**Figure 6-6, (1)**).

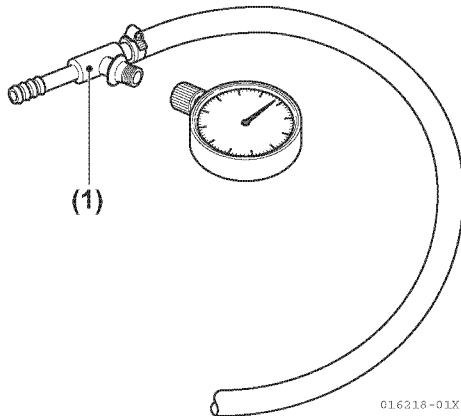

Figure 6-6

2. Disconnect the fuel hose from the fuel fine filter inlet (**Figure 6-7, (1)**).

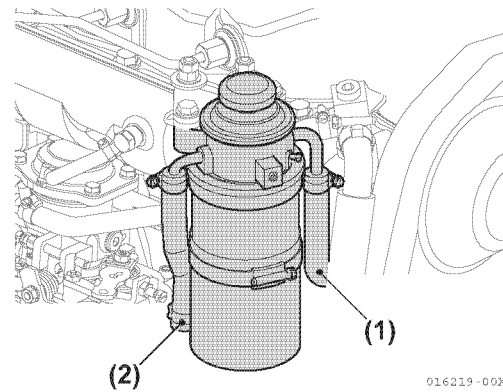

Figure 6-7

3. Connect the test gauge assembly between disconnected ends. Install and tighten hose clamps.
4. Start engine and set speed to low idle. Read and record pressure.
5. Operate engine at full load. Read and record pressure.
6. Repeat procedure at the outlet end of the fuel fine filter (**Figure 6-7, (2)**).

Specification

Inspection Item	RPM	Specification
Fuel Feed Pump Pressure (Minimum)	All	20 kPa (2.9 psi)

Results

- If pressure reading is not within specification, inspect pre-filter (if equipped), fuel filter / water separator, fuel fine filter, and fuel feed pump.
- Measure vacuum / restriction before the electric pump. This value should not exceed 1000 mm Aq (40 in. Aq). If it exceeds the specification, correct restriction from the fuel tank to the engine.
- If fuel feed pump pressure is significantly less than 20 kPa (29 psi), and inlet restriction and return line pressure are within specifications, replace the electric fuel feed pump.

Test Return Fuel Pressure

Note: This test is dependent on the fuel supply. Test the low-pressure fuel system prior to performing this test. See *Measure Fuel Feed Pump Pressure Procedure* on page 6-12.

1. Assemble a tee, hose and 0 to 100 kPa (0 to 15 psi) pressure gauge.
2. Disconnect the hose from the fuel return line (Figure 6-8, (5)).

3. Connect test gauge assembly between disconnected ends. Install and tighten hose clamps.
4. Start engine and allow speed to stabilize at normal low idle.
5. Read and record pressure.

Specification

Inspection Item	RPM	Pressure
Return Fuel Pressure	All speeds	20 kPa (2.9 psi)

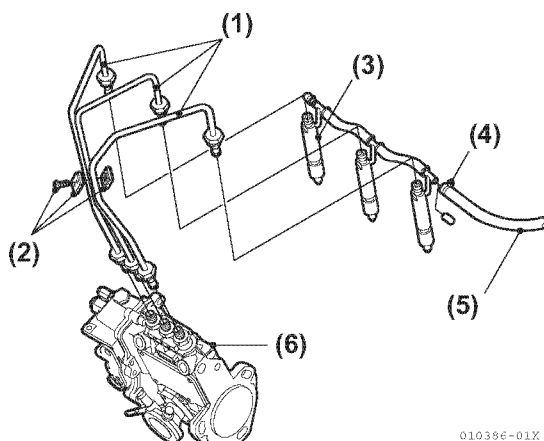

Figure 6-8

Results

- If test pressure reading is not within specifications, find and correct the return fuel restriction.

FUEL SYSTEM SERVICE

After completing work that involves opening the fuel system, do the following:

- Bleed the system.
- Start engine and check for leaks. Allow engine to run until it is running smoothly.
- Check and delete any trouble codes that are registered in the ECU after the work has been completed.

Fuel Injection Nozzle Removal

NOTICE: When working on the oil, coolant or fuel circuits you must protect the alternator from contamination. Cover alternator with suitable materials. Failure to comply may result in an alternator failure.

1. Disconnect the negative (-) battery cable.
2. Shut off all valves in the fuel supply system.
3. Remove bonnet.
4. Remove return fuel line from fuel injection nozzle (**Figure 6-9, (4)**).

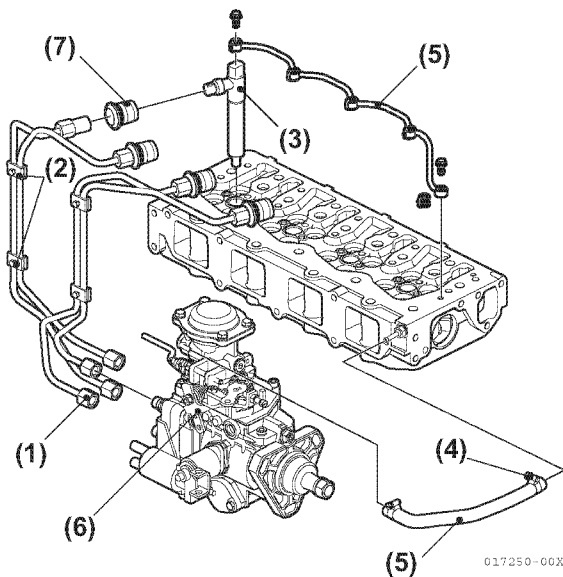

Figure 6-9

5. Remove the bolt retaining the fuel injection nozzle. Remove fuel injection nozzle (**Figure 6-9, (3)**). See *Remove the fuel injection line (Figure 5-32) thru (Figure 5-34): on page 5-40.*
6. If the injection nozzle is stuck, use a slide hammer to remove it from the cylinder head. *NOTICE: DO NOT disassemble the fuel injection nozzle. Replace the entire unit as necessary.*
7. If the injection nozzle gasket did not come out together with the injection nozzle, remove it from the bottom of the injection nozzle seat (**Figure 6-10, (6)**).

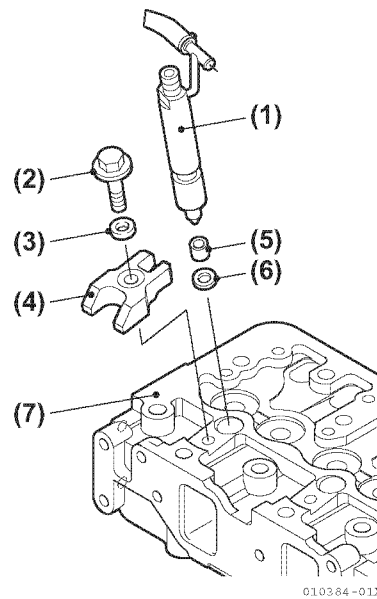

Figure 6-10

Cleaning Fuel Injection Nozzle Cavities

1. Remove fuel injection nozzle.
2. Clean the fuel injection cavities.
3. Inspect to ensure sealing surface is clean. Repeat cleaning if necessary.
4. Install fuel injection nozzle and high-pressure line.
5. Run engine and check for fuel leaks.
WARNING! NEVER check for fuel leaks with your hand.

Fuel Injection Nozzle Installation

1. Make sure that the old gasket is not at the bottom of the injection nozzle seat. Clean the sealing surfaces of the injection nozzle seat. *See Cleaning Fuel Injection Nozzle Cavities on page 6-15. NOTICE: Always install a new gasket when installing an injection nozzle. Make sure all sealing surfaces are clean.*
2. Install new gasket (Figure 6-11, (6)) on tip of injection nozzle (Figure 6-11, (1)) and (Figure 6-12, (5)).

2-Valve Head

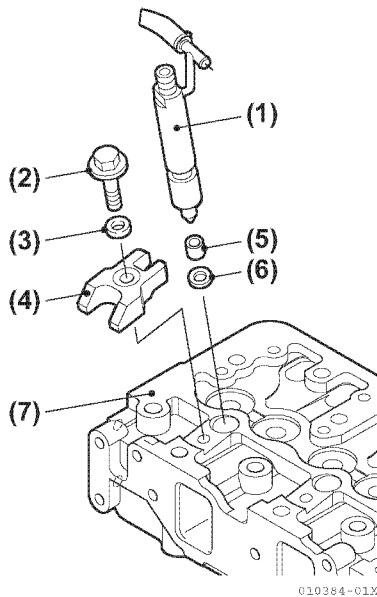

Figure 6-11

4-Valve Head

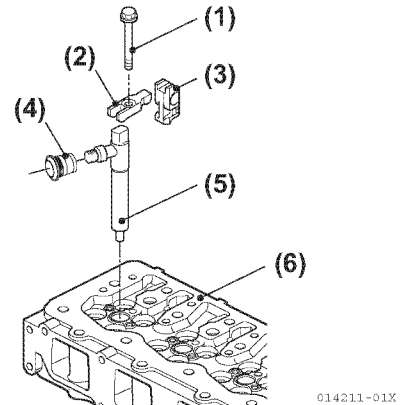

Figure 6-12

3. Place the retainer (Figure 6-11, (4)) for 3JH4E or (Figure 6-12, (3)) for 4JH4-TE and 4JH4-HTE on the injection nozzle as shown.

Note: If installing used fuel injection nozzles, clean the injection nozzle prior to installation.

4. 4JH4-TE and 4JH4-HTE: Install the pipe seal (Figure 6-12, (4)).
5. Install the injection nozzle and retainer as an assembly.
6. Install bolt and washer (Figure 6-11, (2, 3)) and tighten to 26 N·m (19.2 in.-lb).

7. Install the fuel injection lines (**Figure 6-13, (1)**) and (**Figure 6-14, (1)**). See *Fuel Injection Nozzle Installation* on page 6-15.

3JH4E and 4JH4AE Engines

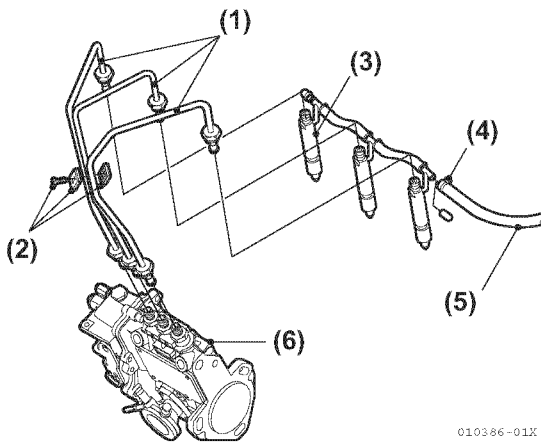

Figure 6-13

4JH4-TE and 4JH4-HTE Engines

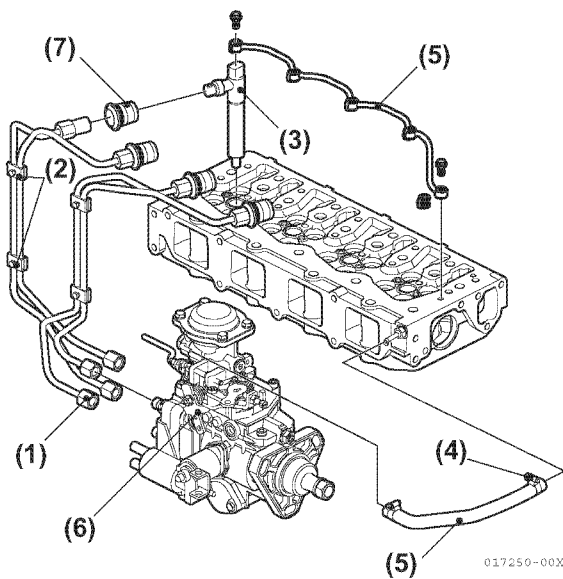

Figure 6-14

8. If removed, install clamps(s) (**Figure 6-13, (2)**) and (**Figure 6-14, (2)**).
9. Install injection nozzle return fuel lines (**Figure 6-13, (4)**) and (**Figure 6-14, (4)**) and (**5**). See *Fuel Injection Nozzle Installation* on page 6-15.
10. 4JH4-TE and 4JH4-HTE: Install pipe seal (**Figure 6-14, (7)**).
11. Open all fuel supply valves.
12. Connect the negative (-) battery cable.
13. Fill and bleed fuel system. See *Bleeding the Fuel System* on page 6-40.
14. Start the engine and check for fuel leaks.
WARNING! NEVER check for fuel leaks with your hand. Allow the engine to run until it is running smoothly. **NOTICE: When working on the oil, coolant or fuel circuits you must protect the alternator from contamination. Cover alternator with suitable materials. Failure to comply may result in an alternator failure.**

Fuel Injection Lines Removal

1. Disconnect the negative (-) battery cable.
2. Shut off all valves in fuel supply system.
3. If removing only one line, remove the clamp joining the fuel injection lines to each other.

Note: Identify all lines to ease installation.

- Loosen retainer bolts on fuel injection line(s) (Figure 6-15, (3)) and (Figure 6-16, (2)).

3JH4E and 4JH4AE Engines

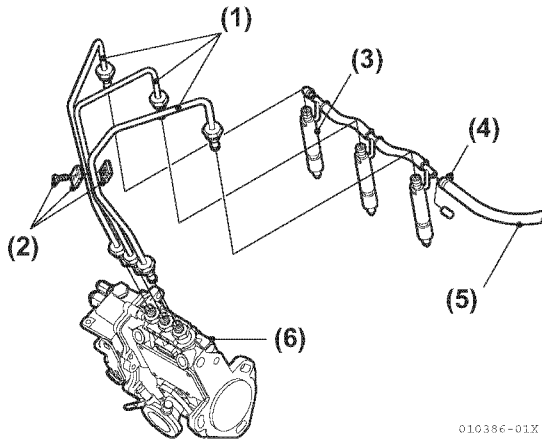

Figure 6-15

4JH4-TE and 4JH4-HTE Engines

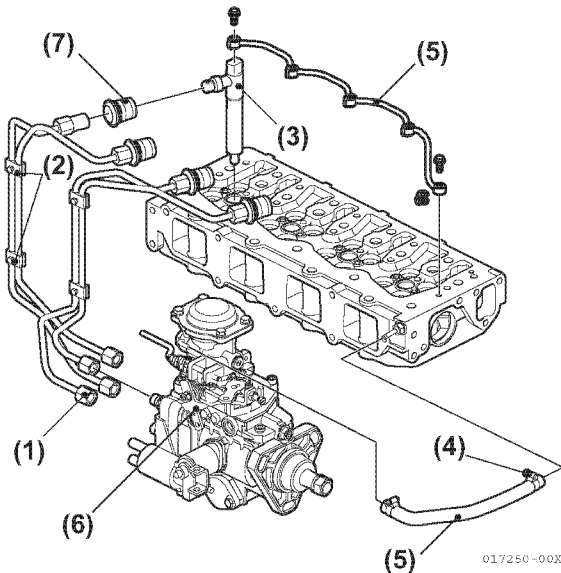

Figure 6-16

- Remove fuel injection line(s). **NOTICE:** Immediately cap or plug all openings to prevent contamination of system.

Fuel Injection Line Installation

- Install line(s) and start all union nuts before tightening any. Hand-tighten all union nuts.

Note: Always use a special tool when loosening or tightening fuel injection line union nuts.

NOTICE: Be sure new fuel injection lines are properly positioned and installed.

- Tighten union nuts to 32 N·m (24 lb-ft).
- Bleed fuel system. See *Bleeding the Fuel System* on page 6-40.
- Start engine and check for fuel leaks. **WARNING! NEVER check for fuel leaks with your hand.**

Fuel Feed Pump Replacement

- Disconnect the negative (-) battery cable.
- Shut off fuel supply valve at fuel tank.
- 4JH4AE: Disconnect electrical connector (Figure 6-17, (1)).

4JH4AE Engine

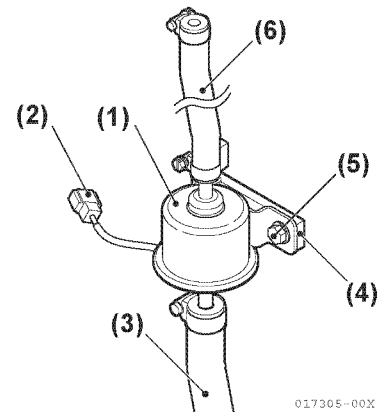

Figure 6-17

- 1 – Electric Fuel Feed Pump
- 2 – Electrical Connector
- 3 – Fuel Supply Line
- 4 – Bracket
- 5 – Bolt
- 6 – Fuel Feed Line to Filter

4. Remove supply line (Figure 6-18, (2)), (Figure 6-19, (16)) and pressure line (Figure 6-19, (2)), (Figure 6-19, (7)) from fuel feed pump. Install caps or plugs on all open fittings to prevent contamination of the fuel system.

3JH4E Engine

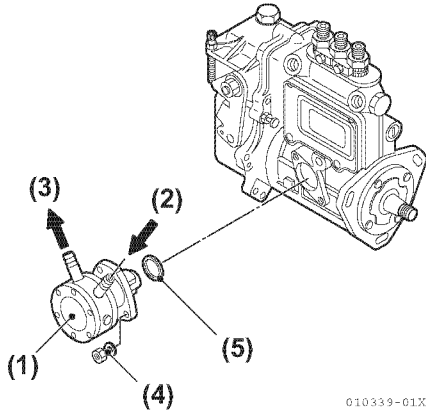

Figure 6-18

5. Remove bolts (Figure 6-18, (4)) and packing (Figure 6-18, (5)).
6. Transfer fuel pump mounts to new pump.
7. Install new fuel feed pump.
8. Connect supply and pressure lines.
9. Connect electrical wiring connector.
10. Open fuel supply valve.
11. Bleed fuel system. See *Bleeding the Fuel System* on page 6-40.
12. Start engine and check for leaks. **WARNING! NEVER check for fuel leaks with your hand.**

Note: For 4JH4-TE and 4JH4-HTE, the fuel feed pump is built in the fuel injection pump / governor system (Figure 6-19). If fuel pump portion needs to be changed, contact an authorized Bosch service factory or dealer.

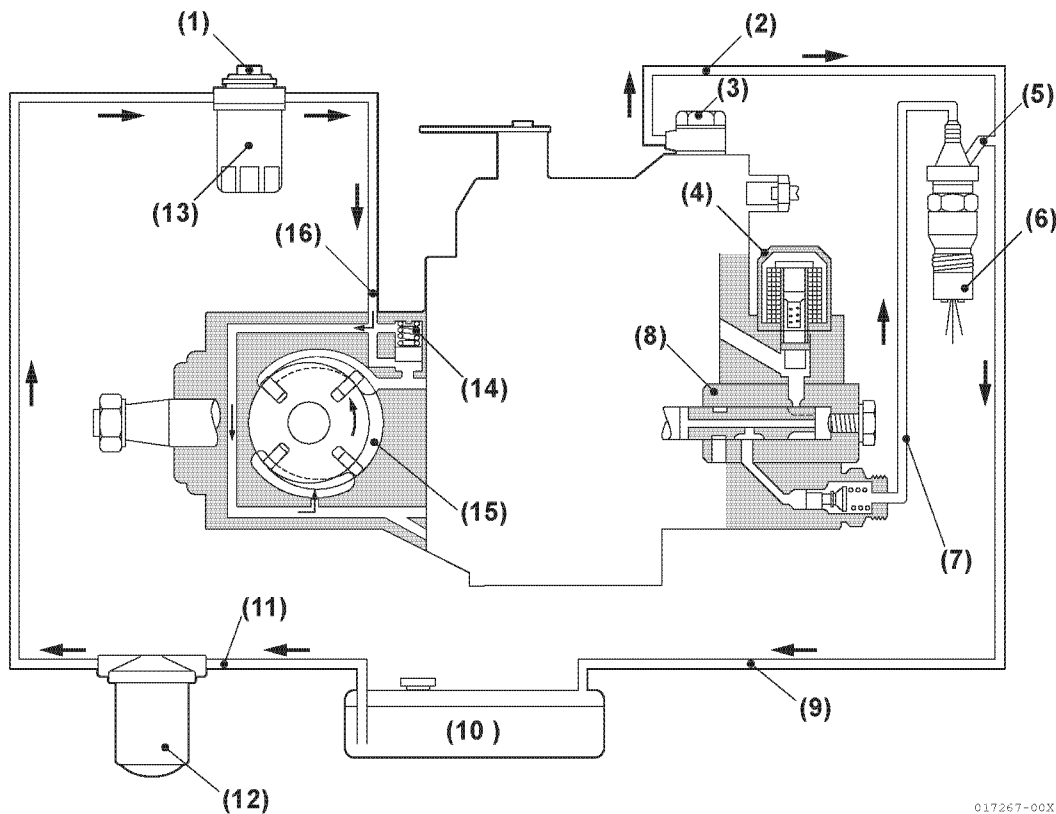

Figure 6-19

Fuel Feed Pump for 3JH4E

The fuel feed pump draws fuel from the fuel tank, passes it through the fuel filter element, and supplies it to the fuel injection pump.

The fuel feed pump is mounted on the side of the engine and is driven by the fuel pump camshaft. It is provided with a manual priming lever so that fuel can be supplied when the engine is stopped.

Design of the fuel feed pump:

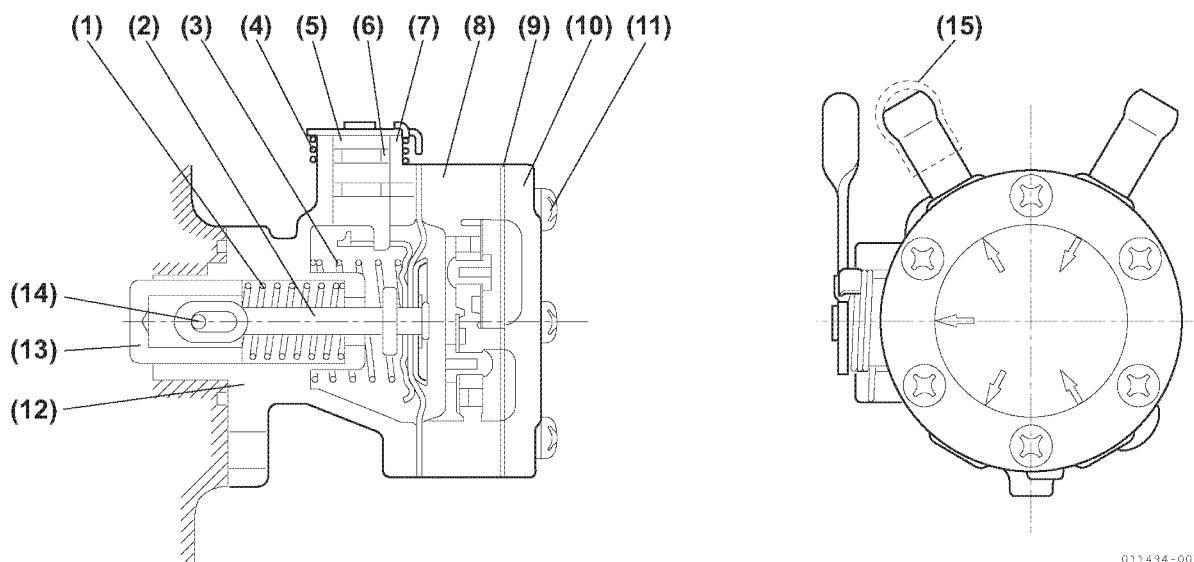

011494-00X

Figure 6-20

- | | |
|--------------------------------|-------------------------|
| 1 – Piston Spring | 9 – Packing |
| 2 – Diaphragm Assembly | 10 – Cover |
| 3 – Diaphragm Spring | 11 – Bolt |
| 4 – Lever Return Spring | 12 – Bottom Body |
| 5 – Lever Assembly | 13 – Piston |
| 6 – O-ring | 14 – Pin |
| 7 – Stop Pin | 15 – Cap |
| 8 – Top Body Assembly | |

Fuel Feed Pump Specifications

Head	1 m Aq
Discharge Volume	230 cm ³ / minimum (0.243 qt / minimum) at 1500 minimum ⁻¹ (rpm) cam Discharge pressure of 0.020 MPa (2.9 psi)
Closed OFF Pressure	0.029 MPa (4.2 psi) or more at 400 minimum ⁻¹ (rpm)

Fuel Feed Pump Disassembly

1. Remove the fuel feed pump mounting nut, and take the fuel feed pump off the fuel injection pump.
2. Clean the fuel feed pump assembly with fuel oil.
3. After checking the orientation of the arrow on the cover, make match marks on the upper body and cover, remove the small bolt, and disassemble the cover, upper body and lower body.

Fuel Feed Pump Assembly

1. Clean all parts with fuel oil, inspect, and replace any defective parts.
2. Replace any packing on parts that have been disassembled.
3. Make sure that the intake valve and discharge valve on upper body are mounted in the proper direction, and that you don't forget the valve packing.
4. Assemble the diaphragm into the body, making sure the diaphragm mounting holes are lined up (do not force).
5. Align the match marks on the upper body of the pump and cover, and tighten the small bolts evenly.

Tightening torque	1.47 - 2.45 N·m (1.08 - 1.81 lb-ft)
-------------------	--

Fuel Feed Pump Inspection

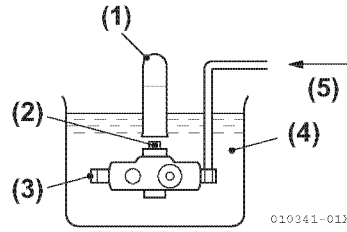

Figure 6-21

- 1 – Measuring Cylinder
- 2 – Tappet
- 3 – Blocked
- 4 – Container Filled With Light Oil
- 5 – Air Pressure

1. Place the fuel feed pump in kerosene, cover the discharge port with your finger, move the priming lever and check for air bubbles (Repair or replace any part which emits air bubbles).
2. Attach a vinyl hose to the fuel feed pump intake, keep the pump at the specified depth from the fuel oil surface, move the priming lever by hand and check for sudden spurts of fuel oil from the discharge port. If oil is not spurting out, inspect the diaphragm and diaphragm spring and repair / replace as necessary.

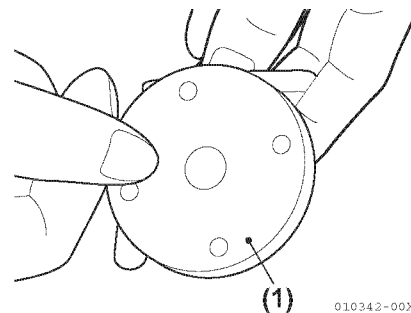

Figure 6-22

- 1 – Diaphragm

3. Inspect the Diaphragm. Parts of the diaphragm that are repeatedly burned will become thinner or deteriorate over a long period of time. Check the diaphragm and replace if necessary.

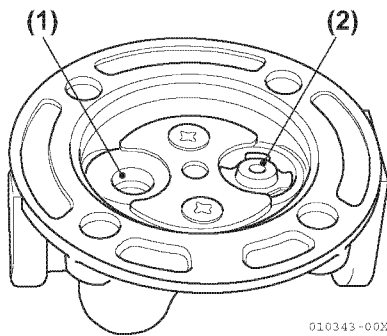

Figure 6-23

- 1 – Inlet Valve
- 2 – Outlet Valve

4. Clean the valve seat and valve with compressed air to remove any foreign matter. **CAUTION! ALWAYS wear eye protection when using compressed air.**
5. Inspect the diaphragm spring and piston spring for settling and the piston for wear, and replace as necessary. **NOTICE: Replace parts as an assembly.**

Fuel Injection Pump Replacement

Removal

NOTICE: When working on the oil, coolant or fuel circuits you must protect the alternator from contamination. Cover alternator with suitable materials. Failure to comply may result in an alternator failure.

1. Disconnect the negative (-) battery cable.
2. Close fuel supply valve at fuel tank.
3. Disconnect electrical connector (Figure 6-24, (2)) from fuel measuring unit.

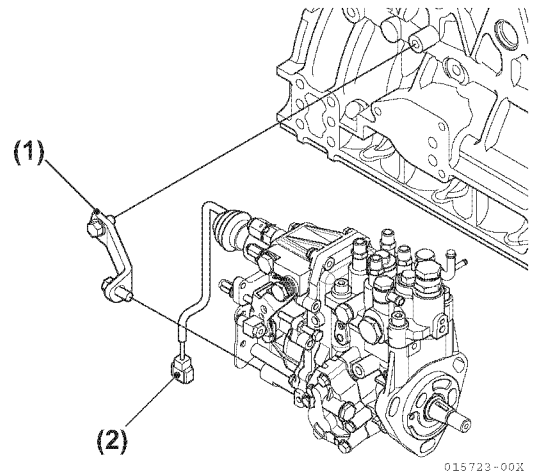

Figure 6-24

4. Disconnect fuel supply line (Figure 6-25, (6)).
4JH4-TE and 4JH4-HTE Engines

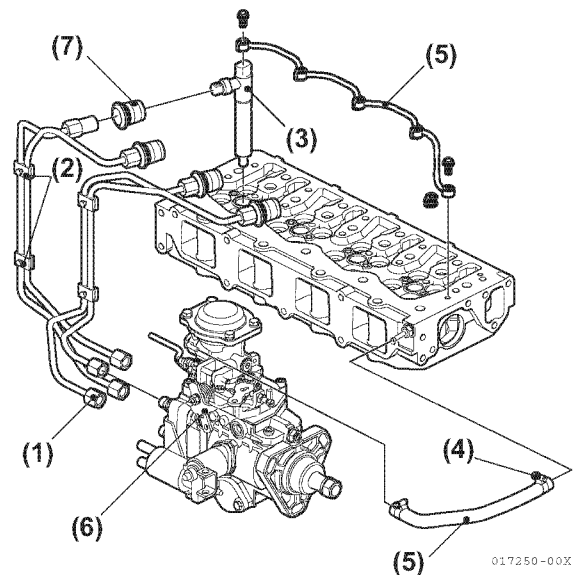

Figure 6-25

5. Disconnect fuel return line (Figure 6-25, (4)).
6. Remove fuel injection line (Figure 6-25, (1)).
7. Remove bolts and support (Figure 6-24, (1)).

8. Hold crankshaft to prevent it from turning and loosen the nut for fuel injection pump drive gear / flange assembly with an extraction tool (Figure 6-26). **CAUTION! Do not disassemble pump flange, fuel pump drive gear and flange bolt.**

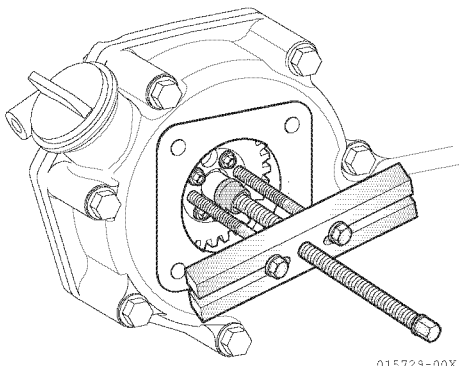

Figure 6-26

9. Remove the fuel injection pump and O-ring from the gear case flange (for 3JH4E and 4JH4AE.) Remove the fuel injection pump and O-ring from the VE pump bracket, which is attached to the gear case flange (4JH4-TE and 4JH4-HTE) (Figure 6-27).

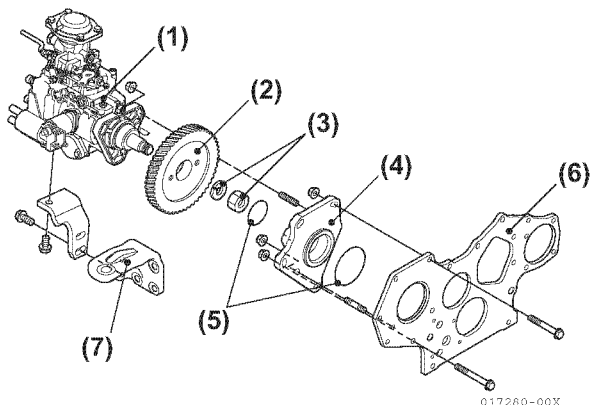

Figure 6-27

10. Install a new fuel injection pump.

Installation

1. Confirm whether the marks of the pump drive gear and the idle gear align.
2. Turn the camshaft so that the key of the camshaft begins to align with the key groove of the pump drive gear.
3. Insert the VE pump and a new O-ring into the hole of the pump bracket. Verify that the key of the camshaft and the key groove of the drive gear are aligned. Lightly tighten the three nuts for the VE pump (Figure 6-28).

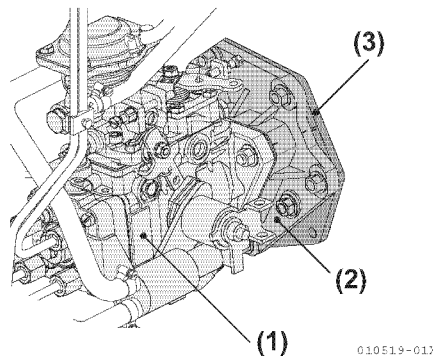

Figure 6-28

Note: Always use new O-Rings on assembly. Be careful not to scratch the O-ring.

4. Tighten the pump drive gear nut and the washer together temporarily.
5. Turn the VE pump to the position where the marks of the VE pump bracket align.
6. Tighten the pump drive gear nut (with lube oil) firmly with the specified standard torque.

Tightening torque	3JH4E	83 N·m
	4JH4AE	(61 lb-ft)
	4JH4-TE	64 N·m
	4JH4-HTE	(47 lb-ft)

7. Tighten the three pump installation nuts firmly. After adjusting the injection timing, tighten the fuel injection pump.
8. Measure the backlash between the pump drive gear and idle gear.

Backlash	0.07 - 0.15 mm 0.0028 - 0.0059 in.
----------	---------------------------------------

Adjust Fuel Injection Timing

See *Checking and Adjusting Fuel Injection Timing* on page 6-58 and *See Position of Top Dead Center and Fuel Injection Timing* on page 5-82.

1. Install high-pressure line and tighten union nuts. See *Remove the fuel injection line (Figure 5-32) thru (Figure 5-34):* on page 5-40.
2. Connect fuel return line.
3. Connect fuel supply line.
4. Connect electrical connector.
5. Open fuel supply valve.
6. Bleed fuel system. See *Bleeding the Fuel System* on page 6-40.
7. Start the engine and check for leaks.
WARNING! NEVER check for fuel leaks with your hand.

Fuel injection pump structure for 3JH4E.

Section of a fuel injection pump / governor for 3JH4(B)(C)E Engines.

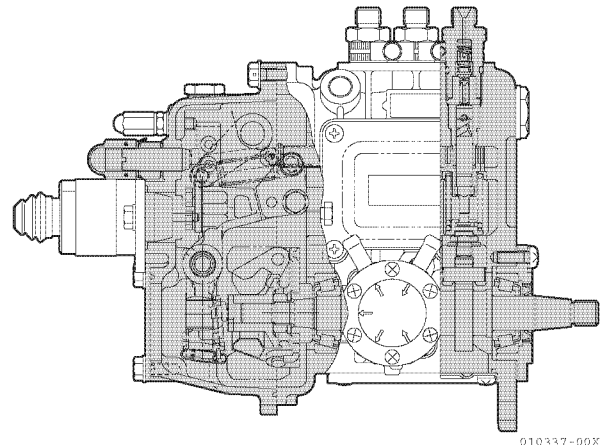

Figure 6-29

Fuel Injection Pump Structure for 4JH4-TE and 4JH4-HTE

NOTICE: The disassembly and adjustment of a fuel injection pump need expertise and facilities. Refer to a Bosch service shop for assistance.

Specifications: The fuel injection pump is VE type (Manufactured by Bosch).

Fuel Injection Pump	VE type
Fuel Feed Pump	Vane type (built-in)
Timer	Hydraulic (built-in)

Model	VE4/12F	
Direction of Rotation	Clockwise (viewed from the drive side)	
Plunger Diameter	ø12 mm	
Governor Type	All speed	
Fuel Feed Type	Vane	
Timer Advancing Angle	4JH4-TE	4JH4-HTE
	1.5°/1100 - 1600 minimum ⁻¹ (pump speed)	2.6°/1200 - 1600 minimum ⁻¹ (pump speed)
Lubricating Method	Fuel oil lubricating	
Fuel Cut Method	<ul style="list-style-type: none"> • Magnetic valve (normal open) • With a manual stop lever 	
Additional Device	Boost compensator	

Model Designation:

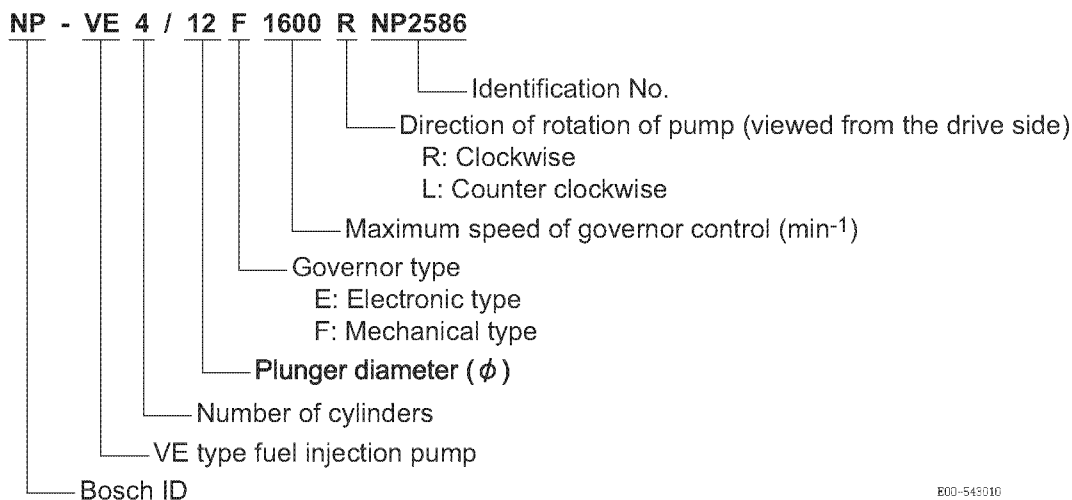

E00-549010

Structure and Function

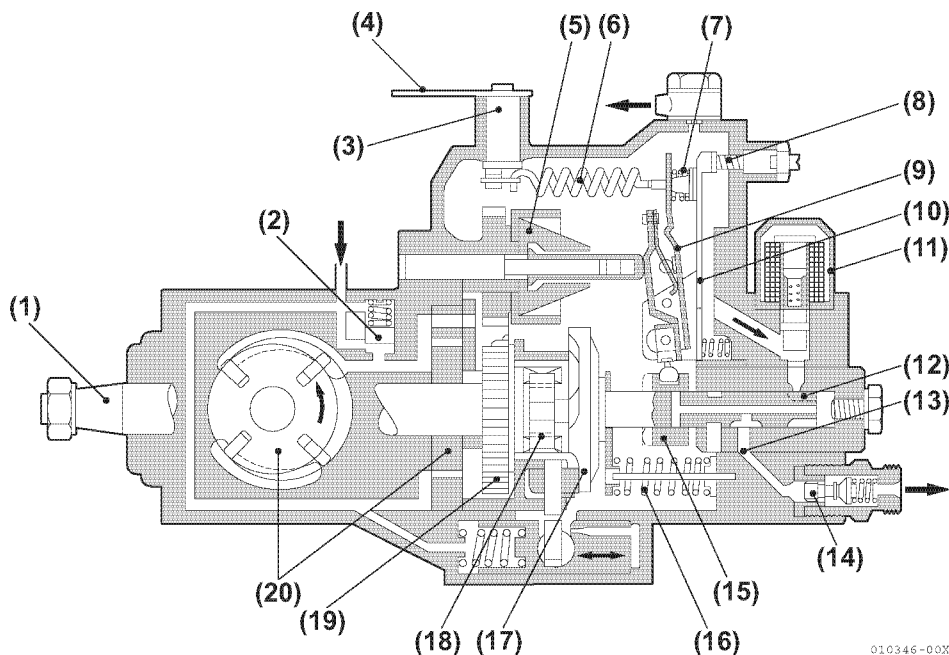

Figure 6-30

- | | |
|-------------------------------|---------------------|
| 1 – Driveshaft | 11 – Magnetic Valve |
| 2 – Regulating Valve | 12 – Plunger |
| 3 – Control Lever Shaft | 13 – Outlet Port |
| 4 – Control Lever | 14 – Delivery Valve |
| 5 – Flyweight | 15 – Control Sleeve |
| 6 – Governor Spring | 16 – Plunger Spring |
| 7 – Idling Spring | 17 – Cam Disk |
| 8 – Full Load Adjusting Screw | 18 – Cross Coupling |
| 9 – Tension Lever | 19 – Drive Gear |
| 10 – Governor Lever Assembly | 20 – Feed Pump |

Plunger

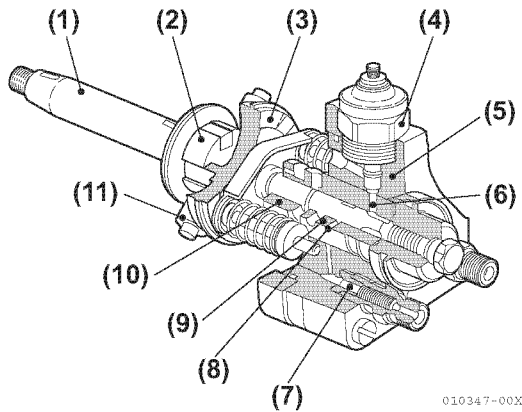

Figure 6-31

- 1 – Driveshaft
- 2 – Cross Coupling
- 3 – Cam Disk
- 4 – Magnetic Valve
- 5 – Distributor Head
- 6 – Inlet Port
- 7 – Delivery Valve
- 8 – Outlet Port
- 9 – Plunger Barrel
- 10 – Control Sleeve
- 11 – Roller

- (a) The driveshaft directly receives the engine rotation by means of gears and transfers the rotation to the cam disk through the cross coupling. The positioning pin press-fitted to the cam disk is also inserted in the groove of the plunger flange, so that the plunger and cam disk rotate in the same direction. The cam disk has a face cam to reciprocate by a specified cam lift on the roller of the roller holder assembly.
- (b) There are two plunger springs having setting forces on the outside of the plunger. They return the plunger which is pushed up by the cam disk, in the descending process. That is, the plunger rotates by means of the driveshaft and reciprocates by means of the cam disk.

When the fuel whose pressure is increased by the plunger is sent to the outlet port, the delivery valve opens to allow the fuel to be injected into the combustion chamber through the fuel injection nozzle.

Governor

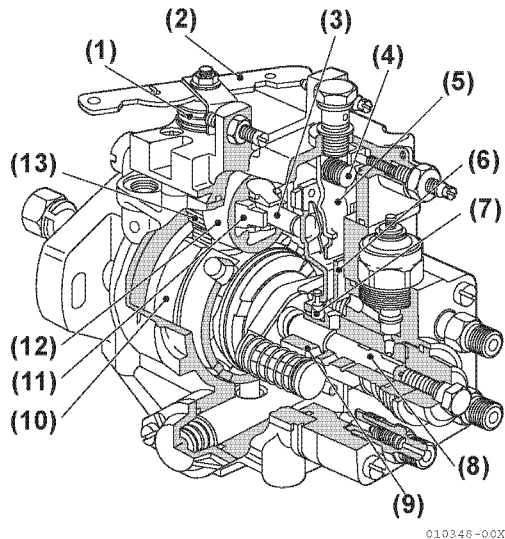
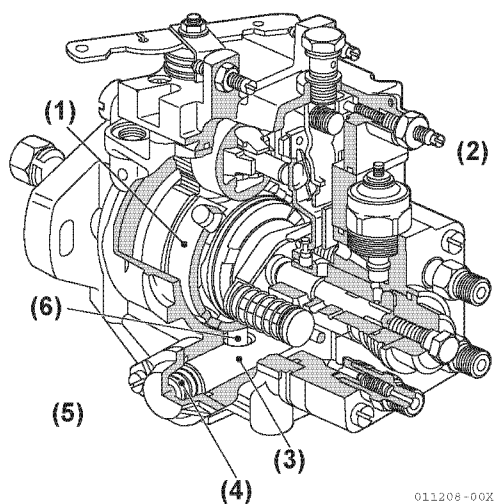

Figure 6-32

- 1 – Control Lever Shaft
- 2 – Control Lever
- 3 – Governor Sleeve
- 4 – Retaining Pin
- 5 – Tension Lever
- 6 – Governor Lever Assembly
- 7 – Ball Pin
- 8 – Plunger
- 9 – Control Sleeve
- 10 – Drive Gear
- 11 – Flyweight
- 12 – Flyweight Holder
- 13 – Flyweight Holder Gear

- (a) The governor, which is located above the pump house, consists of a flyweight holder, governor lever assembly, etc. The flyweight holder holds four flyweights and governor sleeve and is supported by the governor shaft. The drive gear engages with the flyweight holder gear and speeds up the driveshaft rotation to rotate the flyweight holder assembly. The governor lever assembly is supported by the pivot bolt in the pump housing and the ball pin located at the bottom of it is inserted in the control sleeve which slides on the outside surface of the plunger.
- (b) The governor spring located at the top of it is connected to the tension lever with the retaining pin and the governor spring end face is connected to the control lever through the control lever shaft.

The control lever is linked to the governor handle through the link to vary the setting force of the governor spring according to the inclined angle. A difference between the setting force of the governor spring and the centrifugal force of the flyweight corresponds to the control sleeve movement which increases or decreases the injection quantity.

Timer**Figure 6-33**

- 1 – Roller Holder
- 2 – High-Pressure Side
- 3 – Timer Pin
- 4 – Timer Spring
- 5 – Low Pressure Side
- 6 – Roller Holder Pin

There is a built-in timer at the bottom of the injection pump. A timer spring having a setting force is installed on the low pressure side. The fuel pressure in the pump house is directly applied to the opposite side (high-pressure side). The position of the timer piston varies according to the relation between this fuel pressure and timer spring force and the roller holder is rotated through the roller holder pin.

When the piston moves in the direction where the timer spring is shrunk, a lead of angle takes place (the roller holder moves in the reverse direction of rotation) to advance the injection timing. That is, the timer controls the injection timing according to the fuel oil pressure in the pump house.

Boost compensator

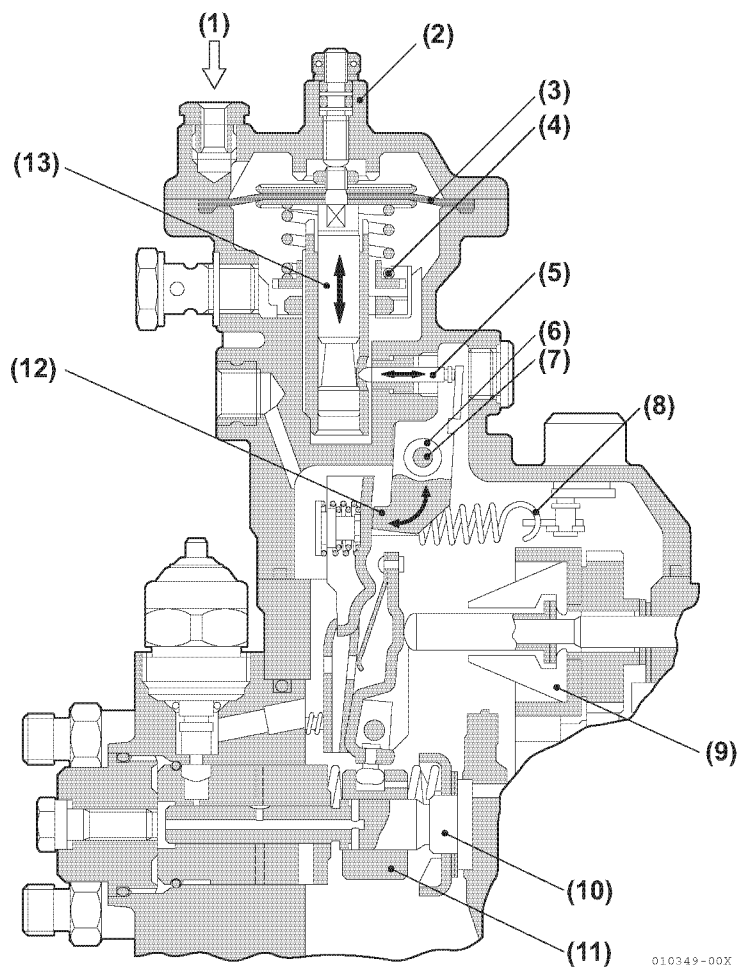

Figure 6-34

- | | |
|---------------------------------|----------------------------|
| 1 – Boost Pressure Inlet | 8 – Governor Spring |
| 2 – Boocon | 9 – Flyweight |
| 3 – Diaphragm | 10 – Plunger |
| 4 – Boocon Spring | 11 – Control Sleeve |
| 5 – Connecting Pin | 12 – Tension Lever |
| 6 – Boocon Lever | 13 – Adjusting Pin |
| 7 – Supporting Point A | |

Note: The following description is based on the service manual issued by the Service Department of Bosch.

- (a) The boost compensator stopper (abbreviated to "boocon") is a device which increases the injection quantity when the air quantity (turbocharging boost) supplied to the suction manifold is increased.
- (b) The boocon is installed on the top of the injection pump governor. There is a diaphragm in an upper part of the boocon and the boost pressure is applied to the upper part with this diaphragm as the boundary. A boocon spring with a setting force is installed under the diaphragm. An adjusting pin is directly connected to the diaphragm so that it will move in conjunction with the diaphragm. A specified amount of lubricant necessary for sliding is stored at the bottom of the adjusting pin.
- (c) The tension lever in the injection pump is drawn to the right by the governor spring. This motion causes the boocon lever to rotate counterclockwise round the supporting point A to push the connecting pin against the taper of the adjusting pin. Therefore, when the adjusting pin moves downward or upward through the diaphragm, this movement is transferred to the connecting pin boocon lever tension lever, so that the control sleeve position (injection quantity) can be changed directly.
- (d) For the boocon, the set value cannot be changed.

Wax Type Cold Start Device (W-C.S.D.)

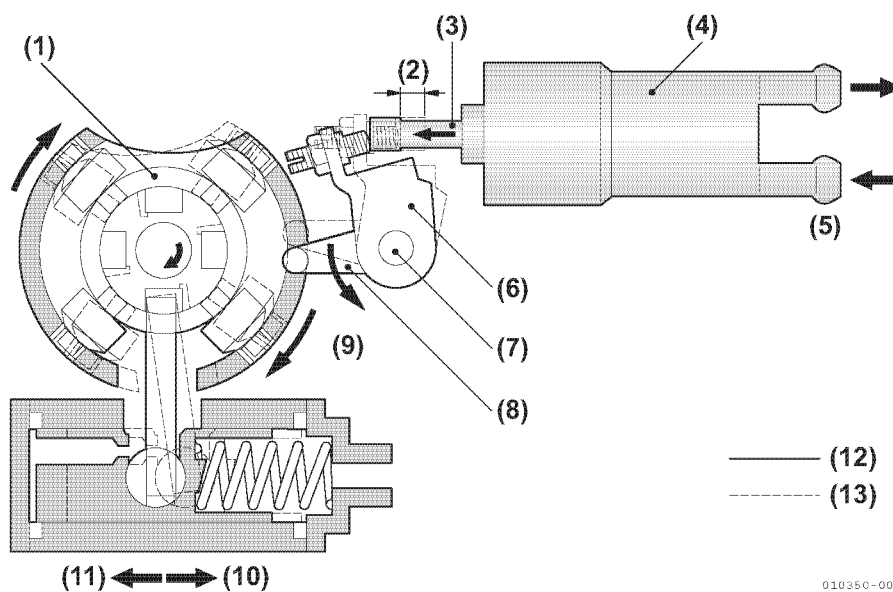

010350-00X

Figure 6-35

- | | |
|---------------------|---------------------|
| 1 – Roller Holder | 8 – Pump Side Lever |
| 2 – Expand | 9 – Cancel |
| 3 – W-C.S.D. Piston | 10 – Advance |
| 4 – W-C.S.D. | 11 – Retard |
| 5 – Engine Coolant | 12 – Cold |
| 6 – C.S.D. Lever | 13 – Hot |
| 7 – Lever Shaft | |

W-C.S.D of 4JH4-TE/4JH4-HTE

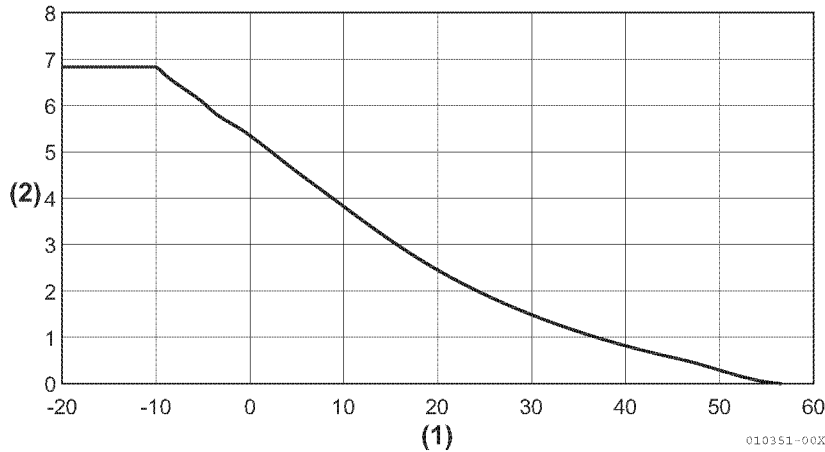

Figure 6-36

- 1 – Temperature of Coolant (°C)
- 2 – Advance Angle (Crank Degrees)

This device aids the easier start of the engine by advancing the fuel injection timing, when the weather is cold.

The wax element is integrated into the body of the W-C.S.D. The engine coolant is led to the wax element and flowing around it. The wax element is expanded by sensing the temperature of engine coolant and moves the W-C.S.D piston. The movement of W-C.S.D piston turns the pump side lever pin via lever shaft. This pin is connected to the roller holder against cam disk. The movement of W-C.S.D piston changes the fuel injection timing by changing the phase angle between cam disk and roller holder.

When the engine coolant is below -10°C, the wax element becomes most shrunken state; the roller holder comes to the maximum advance angle position (6.8 degrees of crankshaft). When the engine coolant becomes warmer, the wax element expands gradually. The roller holder turns from maximum advance angle position to smaller advance angle position. When the temperature is higher than 56°C, the advance function of W-C.S.D is completely canceled. At standard engine operation state, temperature of engine coolant becomes over 56°C, and W-C.S.D never affects the exhaust emission.

3JH4E Fuel Injection Pump Service Data

Part Code (Back No.)		-	729271-51450 (TM02)		
Adjustment SPEC		-	ENG SPEC	SERVICE STD	
Item	Fuel Valve (Valve Pressure)	-	VBG (220)	(170)	
	Nozzle Type (ID Mark)	-	159P185VAD1	DN-12SD12	
	FUEL INJECTION PIPE	mm	∅1.6 x 360	∅2 x 600	
Injection Adjustment	Starting	Pump Speed N _s	minimum ⁻¹	200	200
		Average Injection Volume Q _s	mm ³ /st	45 ± 5.0	50 ± 5.0
	Rated Load	Pump Speed N _o	minimum ⁻¹	1500	1500
		Injection Volume Q _o	mm ³ /st	32.5 ± 0.75	56.5 ± 0.75
		Nonuniformity	%	± 3	± 3
	Torque Rise	Pump Speed N _T	minimum ⁻¹	-	-
		Injection Volume Q _T	mm ³ /st	-	-
		Nonuniformity	%	-	-
	Hi-Idle	Pump Speed N _{Hi}	minimum ⁻¹	1660 ⁺¹⁵ / ₋₁₀	1660 ⁺¹⁵ / ₋₁₀
		Injection Volume Q _{Hi}	mm ³ /st	6 - 7	18 - 19
	Idle	Pump Speed N _i	minimum ⁻¹	400	400
		Q _i	mm ³ /st	6 - 7	7 - 8
		Nonuniformity	%	± 15	± 15
	Plunger Stroke		mm	8.0	
	Plunger Dia.		mm	8	
Suction Volume of Delivery Valve		mm ³	36		
Pre-stroke		mm	3.0		
Top Clearance		mm	0.5		
Governor Spring	Spring Constant	N/cm (kgf/cm)	2.76 (0.281)		
	Free Length	mm	41		

4JH4-TE / 4JH4-HTE Fuel Injection Pump Service Data

NOTICE: The disassembly and adjustment of a fuel injection pump need expertise and facilities. Refer to a Bosch service shop for assistance.

Adjustment Conditions	Nozzle Type	Bosh 105780-0060 (NP-DN0S1510)				
	Nozzle Holder	105780-2150				
	Nozzle Opening Pressure	13.0 MPa				
	Fuel Injection Line (Outside Diameter x Inside Diameter-length)	ø6 x 2-450 mm				
	Fuel Oil Feed Pressure	20 kPa				
Engine Model	4JH4-TE					
Adjustment Value	Pump Speed (minimum⁻¹)	Boost Pressure (kPa)	Injection Quantity (mm³/st)	Ununiformity (mm³/st)	Lubricating Oil Temperature (°C)	Remarks
Injection Quantity And Governor	600	0	(83.5)	-	50 ± 2	
	800	40.0 ± 1.3	112 ± 2	-	50 ± 2	Standard
	900	66.7 ± 1.3	127.7 ± 2	10.5	50 ± 2	Standard
	1600	66.7 ± 1.3	(118.2 ± 6)	-	50 ± 2	
	1800	66.7 ± 1.3	58.5 ± 5	-	50 ± 2	Standard
	400	0	8.5 ± 2.5	3.0	48 ± 2	Standard
	100	0	(134.2)	-	48 ± 2	
Timer And Pump Room Pressure	Pump Speed (minimum⁻¹)	Boost Pressure (kPa)	Timer Piston Stroke (mm)	Pump Room Pressure (kPa)		Remarks
	1000	66.7 ± 1.3	0.5 or less	-		
	1500	66.7 ± 1.3	0.9 ± 0.4	520 ± 39		Standard
	1600	66.7 ± 1.3	(1.0 ± 0.6)	-		
Cold Advancer Characteristics	Coolant Temperature (°C)	Timer Piston Stroke (mm)				Remarks
	20	1.04 ± 0.6				Standard
	-10	2.81 ± 0.8				

Adjustment Conditions	Nozzle Type	Bosh 105780-0060 (NP-DN0S1510)				
	Nozzle Holder	105780-2150				
	Nozzle Opening Pressure	13.0 MPa				
	Fuel Injection Line (Outside Diameter x Inside Diameter-length)	ø6 x 2-450 mm				
	Fuel Oil Feed Pressure	20 kPa				
Engine Model	4JH4-HTE					
Adjustment Value	Pump Speed (minimum⁻¹)	Boost Pressure (kPa)	Injection Quantity (mm³/st)	Ununiformity (mm³/st)	Lubricating Oil Temperature (°C)	Remarks
Injection Quantity and Governor	500	0	(43.1)	-	48 ± 2	
	750	40.0 ± 1.3	91.2 ± 2	-	50 ± 2	Standard
	1100	80.0 ± 1.3	128.2 ± 2	10.5	50 ± 2	Standard
	1600	80.0 ± 1.3	(124.0 ± 6)	-	50 ± 2	
	1750	80.0 ± 1.3	60.3 ± 5	-	50 ± 2	Standard
	380	0	8.0 ± 2.5	3.0	48 ± 2	Standard
	100	0	(110)	-	48 ± 2	
Timer and Pump Room Pressure	Pump Speed (minimum⁻¹)	Boost Pressure (kPa)	Timer Piston Stroke (mm)	Pump Room Pressure (kPa)		Remarks
	1200	80.0 ± 1.3	0.5 or less	-		
	1500	80.0 ± 1.3	1.2 ± 0.4	569 ± 39		Standard
	1600	80.0 ± 1.3	(2.1 ± 0.6)	-		
Cold Advancer Characteristics	Coolant Temperature (°C)	Timer Piston Stroke (mm)				Remarks
	20	1.04 ± 0.6				Standard
	-10	2.81 ± 0.8				

- Adjusting fuel limit bolt at starting

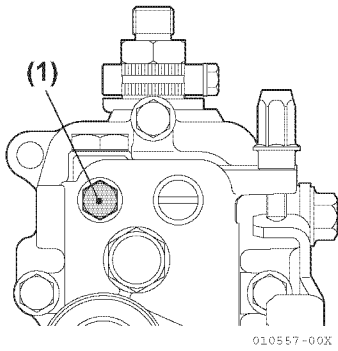

Figure 6-37

1 – Fuel Limit Bolt at Starting

- Adjust the fuel limit bolt at starting to bring the rack position to the specified value (Rs), while keeping the pump at starting speed Ns.
- Measure fuel injection volume at starting position (Rs).
- If the injection volume is at the specified value, tighten the fuel limit bolt locknut at that position.

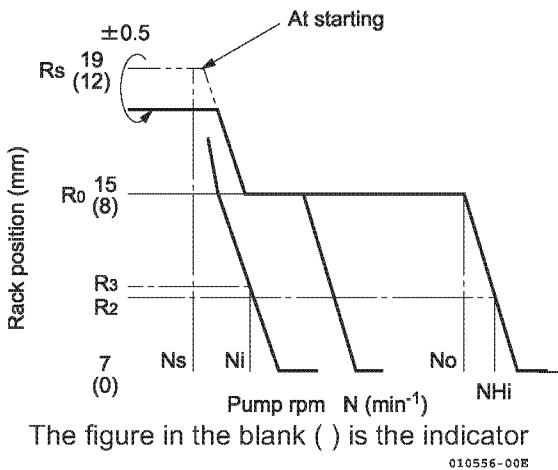

Figure 6-38

Fuel Line Replacement Filter

1. Disconnect the negative (-) battery cable.
2. Close the fuel tank cock.
3. Loosen inlet (Figure 6-39, (1)), (Figure 6-40, (1)), (Figure 6-41, (1)) and outlet (Figure 6-39, (2)), (Figure 6-40, (2)), (Figure 6-41, (2)) hose clamps and remove hoses from filter.

3JH4E Engine

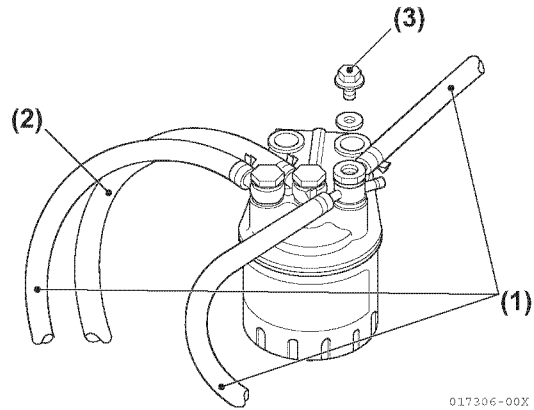

Figure 6-39

4JH4AE Engine

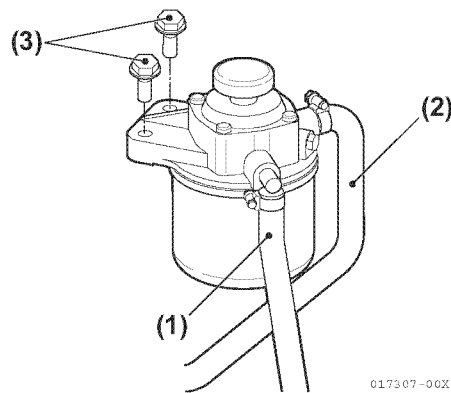

Figure 6-40

4JH4-TE/4JH4-HTE Engines

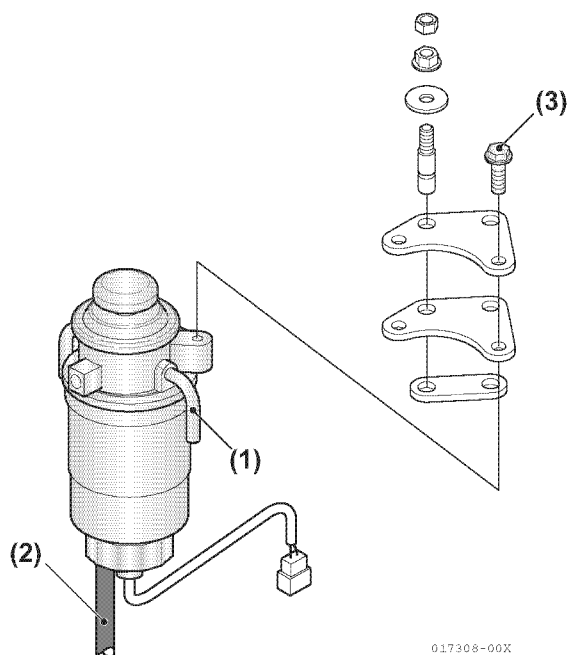

Figure 6-41

4. Remove bolts (Figure 6-39, (3)), (Figure 6-40, (3)), (Figure 6-41, (3)).

5. Remove mounting brackets and install on new filter. Ensure fuel flow direction is correct.
NOTICE: When replacing fuel filters, always pre-fill them with fresh, clean fuel to improve the system ability to be bled.
6. Install on electrical bracket and tighten bolts securely.
7. Install hoses and tighten new clamps to specification. *See Hose Clamps on page 3-55.*
8. Connect negative (-) battery cable.
9. Bleed the fuel system and check for leaks. *See Bleeding the Fuel System on page 6-40.*
WARNING! NEVER check for fuel leaks with your hand.

Fuel / Water Separator Replacement

1. Disconnect the negative (-) battery cable.
2. Close the fuel supply valve.
3. Loosen the drain plug (**Figure 6-42, (2)**), (**Figure 6-43, (1)**) on the bottom of the water separator and drain off any water or dirt.

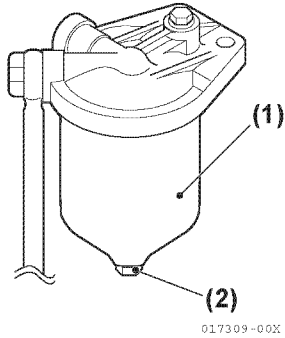

Figure 6-42

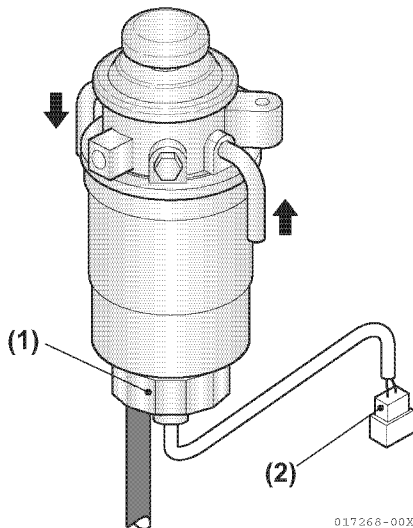

Figure 6-43

4. 4JH4-TE / 4JH4-HTE: Disconnect water sensor connector (**Figure 6-43, (2)**).
5. Remove the old filter element (**Figure 6-44, (1)**), (**Figure 6-45, (1)**).

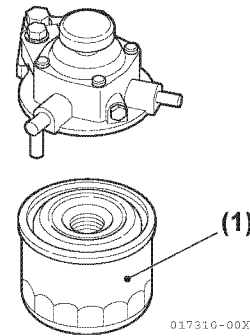

Figure 6-44

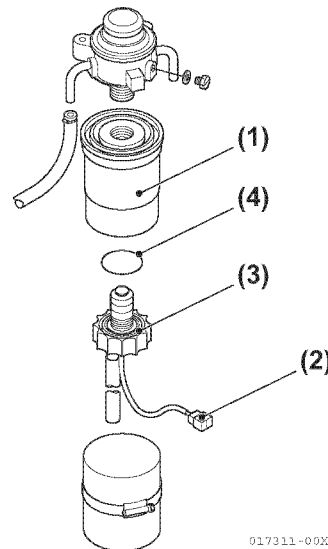

Figure 6-45

6. Clean the filter bowl. Inspect the water sensor probe (**Figure 6-45, (2)**) for damage. Inspect the bowl seal (**Figure 6-45, (4)**). **NOTICE:** When replacing fuel filters, always pre-fill them with fresh, clean fuel to improve the system ability to be bled.
7. Lubricate the seal at the top of the new filter element and install.
8. Lubricate the filter bowl seal and install the filter bowl. Turn clockwise by hand to tighten.
9. Ensure drain plug (**Figure 6-42, (2)**) and (**Figure 6-43, (1)**) is securely tightened.
10. Connect water sensor.
11. Open the fuel supply valve.

12. Connect the negative (-) battery cable.
13. Bleed fuel system and check for leaks. See *Bleeding the Fuel System on page 6-40.*
WARNING! NEVER check for fuel leaks with your hand.

Replace Injection Nozzle Return

Fuel Line

1. Disconnect the negative (-) battery cable.
2. Shut off fuel supply valve.
3. Loosen the clamps (**Figure 6-46, (1)**), (**Figure 6-47, (1)**) and remove fitting from fuel injection nozzle top. Repeat with all fuel injection nozzles. **NOTICE: NEVER disassemble fuel return line assembly. No individual parts are available and it must be replaced as a complete assembly.**

3JH4E Engine

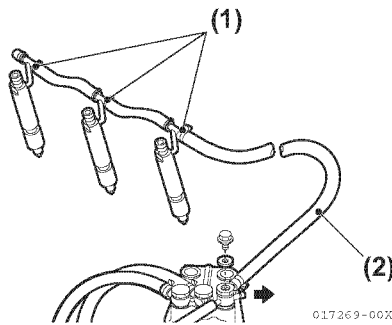

Figure 6-46

4JH4-TE and 4JH4-HTE Engines

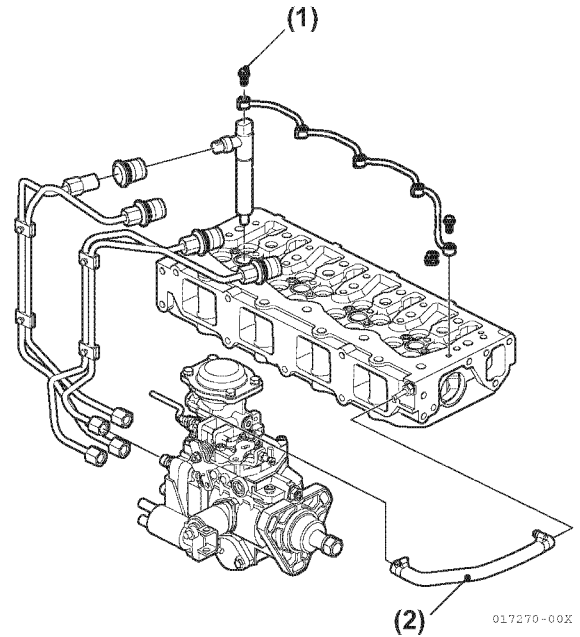

Figure 6-47

4. Disconnect return fuel hose (**Figure 6-46, (2)**).
5. Inspect seal (**Figure 6-47, (1)**) on each fitting. If any packing is damaged, replace it as new packing.
6. Assembly is in the reverse order from disassembly.
7. Open fuel supply valve.
8. Connect the negative (-) battery cable.
9. Start engine and check for fuel leaks.
WARNING! NEVER check for fuel leaks with your hand.

Bleeding the Fuel System

The fuel system needs to be bled under the following conditions:

- Before starting the engine for the first time.
- After running out of fuel and fuel has been added to the fuel tank.
- After fuel system maintenance such as changing a fuel filter, draining the fuel filter / water separator, or replacing a fuel system component.

Fuel System Air Bleeding Procedures

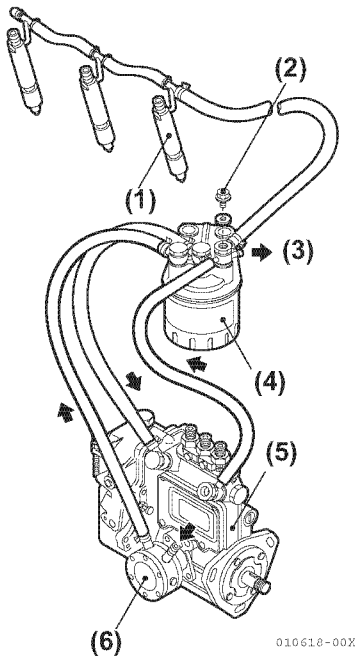

Figure 6-48

- 1 – Fuel Injection Nozzle**
- 2 – Air Bleed Bolt**
- 3 – Fuel Return Line to Fuel tank**
- 4 – Fuel Filter**
- 5 – Fuel Injection Pump**
- 6 – Fuel Feed Pump**

1. Check the fuel level in the fuel tank. Replenish if insufficient.

2. Loosen the air bleeding bolt at the top of the fuel / water separator by turning it 2 or 3 turns. When the fuel no longer contains bubbles, tighten the air bleeding bolt. This completes the air bleeding of the fuel system.
3. Loosen the air bleeding bolt of the fuel filter by turning it 2 or 3 turns.
4. Feed fuel with the fuel feed pump by moving the lever on the left side of the feed pump up and down.
5. Allow the fuel containing air bubbles to flow out from the air bleeding bolt hole. When the fuel no longer contains bubbles, tighten the air bleeding bolt. This completes the air bleeding of the fuel system.
6. After the engine start-up, the automatic air-bleeding device works to purge the air in the fuel system. No manual air-venting is required for normal engine operation.

The electric fuel feed pump of 4JH4AE is an electric fuel feed pump. It will operate when the key switch is turned ON and the engine is not running or being started.

1. Turn the key switch ON and leave ON for 10 seconds.
2. Turn key switch OFF for five seconds, then turn key switch ON for 10 seconds.
3. Repeat steps 1 and 2 five more times.

Note: The engine may run rough and misfire for a few seconds when first started until any remaining air is purged from the fuel system.

4. Attempt to start the engine. If the engine does not start within a reasonable time, repeat steps 1 and 2 until the engine starts and runs.

MP FUEL INJECTION PUMP SYSTEM

Introduction

This section of the *Service Manual* describes the procedures necessary to remove, install, and timing adjustment of the MP fuel injection pump and its associated system components. This fuel injection pump is comparable to the fuel injection pumps used on model 4JH4AE engine.

Fuel Injection Pump

Note: If the MP fuel injection pump itself requires servicing, it must be taken to an authorized Yanmar FIE (Fuel Injection Equipment) repair facility.

CAUTION! NEVER remove or attempt to remove the tamper-proof devices from the full-load fuel adjusting screw or the high-speed throttle limit screw on the fuel injection pump and governor assembly. These adjustments have been made at the factory to meet all applicable emissions regulations and then sealed.

CAUTION! NEVER attempt to make any adjustments to these sealed adjustment screws. If adjustments are required, they can be made only by a qualified fuel injection shop that will ensure the injection pump continues to meet all applicable emissions regulations and then replace the tamper-proof seals.

CAUTION! Tampering with or removing these devices may void the "Yanmar Limited Warranty."

The following describes the features of the MP fuel injection pump, manufactured by Yanmar (Figure 6-49).

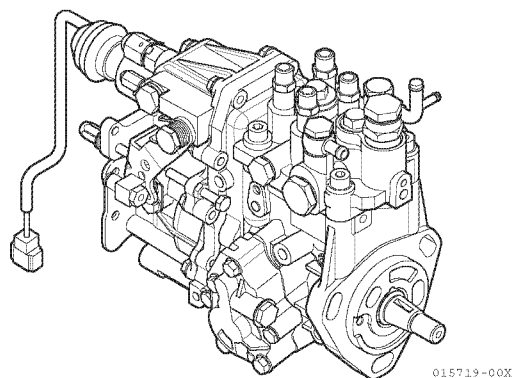

Figure 6-49

The fuel injection pump is a very important component of the engine. It is capable of making very precise fuel delivery adjustments according to the varied loads applied to the engine.

All of the fuel injection pump components are very precisely machined. It is extremely important to follow good service practices and maintain cleanliness when servicing the fuel injection pump.

The Yanmar MP "Mono-Plunger" Fuel Injection Pump is a distributor type pump which consists of a single fuel supply plunger, a distributor shaft, a hydraulic head and a pump housing. The hydraulic head has a delivery valve for each cylinder. The fuel injection pump housing contains a governor and an internal camshaft.

The fuel is pressurized by the up and down motion of the camshaft-driven single plunger. It is then distributed to the proper fuel injector by the rotating distributor shaft.

The MP2 pump is used on model 4JH4AE engine.

Stop Solenoid

The MP fuel injection pumps are equipped with a stop solenoid that controls the fuel flow inside the fuel injection pump.

Usually, no current flows to the stop solenoid and the solenoid plunger is extended releasing the fuel injection pump fuel rack in the “opened” position and allowing fuel to flow through the injection pump and to the engine.

To stop the engine, push the stop button while the key switch is turned to the ON position. Current flows to the stop solenoid “hold coil”, and the solenoid plunger extends and moves the injection pump fuel rack to the “closed” position, shutting off the fuel flow and stopping the engine.

Trochoid Fuel Pump

Note: The trochoid fuel pump located on the side of the MP fuel injection pump is not a “fuel supply” pump. The function of this pump is to raise the pressure of the fuel supplied by the electric fuel supply pump to the internal fuel pressure required by the MP fuel injection pump.

The use of an electric fuel supply pump is required on 4JH4AE model engine with the MP fuel injection pump.

FUEL SYSTEM SPECIFICATIONS

Special Torque Chart

Component		Tightening Torque	Lubricating Oil Application (Thread Portion and Seat Surface)
Fuel Injector Retainer Bolt		39.2 N·m; 4 kgf-m (29 lb-ft)	Not Applied
Fuel Pump Drive Gear Nut	4JH4AE	78 - 88 N·m; 8 - 9 kgf-m (58 - 65 lb-ft)	Not Applied
High-Pressure Fuel Injection Line Nuts		29 - 34 N·m; 3.0 - 3.5 kgf-m (22 - 25 lb-ft)	Not Applied
Fuel Return Line Bolts		7.8 - 9.8 N·m; 0.8 - 1.0 kgf-m (69 - 87 in-lb)	Not Applied
Fuel Injection Pump Mounting Nuts		23 - 28 N·m; 2.3 - 2.9 kgf-m (17 - 21 lb-ft)	Not Applied
Fuel Injector Nozzle Case Nut 0.605-40 UNS-28		39.2 - 44.1 N·m; 4 - 4.5 kgf-m (30 - 33 lb-ft)	Not Applied
Fuel Injection Pump Plunger Plug 119802-51560 M14 x 1.0	4JH4AE	30 - 35 N·m; 3.1 - 3.6 kgf-m (22 - 26 lb-ft)	Not Applied

Fuel Injection Pump Service Data

4PD-4MP2 for 4JH4AE Service Data

Part Code (Back No.)		-	729670-51320 (SH82)		
Adjustment SPEC		-	ENG SPEC	SERVICE STD	
Item	Fuel Valve (Valve Pressure)	(MP2)	VBG (20.1)	-	
	Nozzle Type (ID Mark)	-	156P165VAC0	Single Hole	
	FUEL INJECTION PIPE	mm	∅1.6 x 450	-	
Injection Adjustment	Starting	Pump Speed N _s	minimum ⁻¹	200	200
		Average Injection Volume Q _s	mm ³ /st	60 ± 2	74.8 ± 2.0
	Rated Load	Pump Speed N _o	minimum ⁻¹	1500	1500
		Injection Volume Q _o	mm ³ /st	34.0 ± 0.5	41.9 ± 0.5
		Nonuniformity	%	± 3	± 3
	Torque Rise	Pump Speed N _T	minimum ⁻¹	NYA	-
		Injection Volume Q _T	mm ³ /st	NYA	-
		Nonuniformity	%	NYA	-
	Hi-Idle	Pump Speed N _{Hi}	minimum ⁻¹	1650 ⁺¹⁵ ₋₁₀	1650 ⁺¹⁵ ₋₁₀
		Injection Volume Q _{Hi}	mm ³ /st	8.9 - 9.9	15.7 ± 0.5
	Idle	Pump Speed N _i	minimum ⁻¹	400	400
		Q _i	mm ³ /st	5 - 6	5.6 ± 0.5
		Nonuniformity	%	± 20	± 20
	Plunger Stroke		mm	NYA	
	Plunger Dia.		mm	9	
Suction Volume of Delivery Valve		mm ³	NYA		
Pre-stroke		mm	2.5		
Top Clearance		mm	NYA		
Governor Spring	Spring Constant	N/cm (kgf/cm)	3.73 (0.380)		
	Free Length	mm	38.5		

Test and Adjustment Specifications

Model	Injector ID mark*	Fuel Injector Pressure	Fuel Injection Timing
4JH4AE	WDL	19.6 - 20.6 MPa; 200 - 210 kgf/cm ² (2843 - 2988 psi)	See Checking and Adjusting Fuel Injection Timing on page 6-58

Note: Fuel injection pressure of a new fuel injector is reduced approximately 72.5 psi (0.5 MPa; 5.0 kgf/cm²) after about 5 hours of operation due to the initial break-in of the engine. When adjusting a new fuel injector or after it has been disassembled for service, adjust the fuel injector 72.5 psi (0.5 MPa; 5.0 kgf/cm²) higher than the above standard.

Note: Every fuel injector has a three character identification mark (**Figure 6-50, (1)**) such as 4JH4AE: WDL.

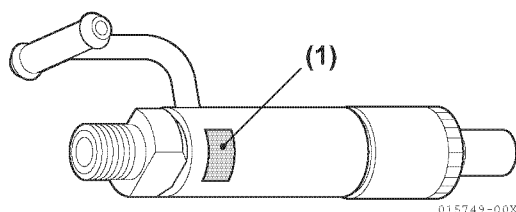
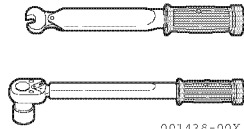
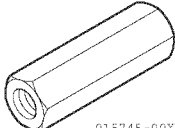

Figure 6-50

* Fuel injector identification is critical as each engine has a unique fuel injection pressure. The fuel nozzle is specifically matched to the fuel injector by engine model and / or engine speed.

SPECIAL SERVICE TOOLS

No.	Tool Name		Application	Illustration
1	Torque Wrench	Locally Available	For tightening nuts and bolts to the specified torque	 001438-00X
2	Fuel Injector Removal Tool	Yanmar Part No. 129470-92305	Used in conjunction with a slide hammer to remove the fuel injectors (2-valve cylinder heads)	 015745-00X

MEASURING INSTRUMENTS

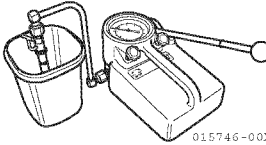
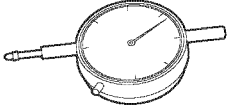
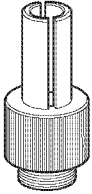
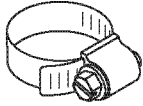
No.	Instrument Name		Application	Illustration
1	Fuel Injector Tester	Locally Available	For observing injection spray pattern of fuel injection nozzle and measuring injection pressure	 015746-00X
2	Dial Indicator*	Mitutoyo 2050SB - Locally Available	Check and adjust fuel injection timing	 001429-00X
	Extension Rod*	Mitutoyo 303613 - Locally Available		
3	Fuel Injection Pump Plunger Adapter*	(M14) TNV82-88 - Yanmar Part No. 158090-51831	Mount dial indicator to fuel injection pump	 015747-00X
		(M16) TNV94-106 - Yanmar Part No. 158090-51841		
4	Plunger Adapter Clamp	Yanmar Part No. 23000-013000	Clamps stem of dial indicator in plunger adapter.	 015748-00X

* These special service tools may also be available as an "MP Fuel Injection Pump Special Tool Set", under a different part number, in territories serviced by Yanmar America and Yanmar Europe. Contact your authorized Yanmar dealer or distributor for details.

FUEL SYSTEM DIAGRAM

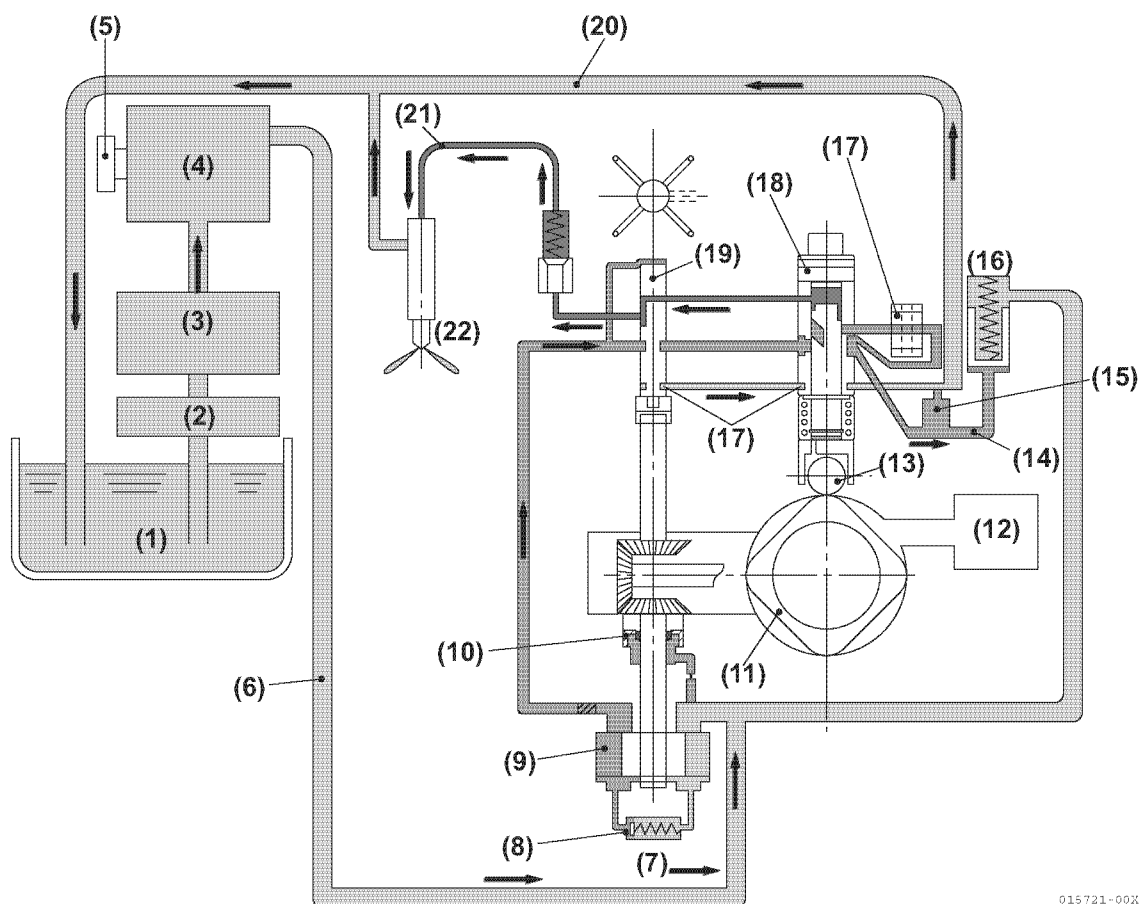

015721-00X

Figure 6-51

- | | |
|-----------------------------------|---|
| 1 – Diesel Fuel Tank | 12 – Engine Crankcase |
| 2 – Fuel Filter / Water Separator | 13 – Tappet |
| 3 – Electric Fuel Feed Pump | 14 – High-Pressure Gallery |
| 4 – Fuel Filter | 15 – Overflow Orifice |
| 5 – Priming Pump | 16 – Accumulator |
| 6 – Fuel Supply Line | 17 – Timer Piston |
| 7 – Low Pressure Gallery | 18 – Mono-Plunger |
| 8 – Pressure Control Valve | 19 – Distributor Shaft |
| 9 – Trochoid Pump | 20 – Fuel Return Line |
| 10 – Oil Seal | 21 – High-Pressure Fuel Injection Lines |
| 11 – Fuel Injection Pump Cam | 22 – Fuel Injector |

FUEL SYSTEM COMPONENTS

4JH4AE Engine

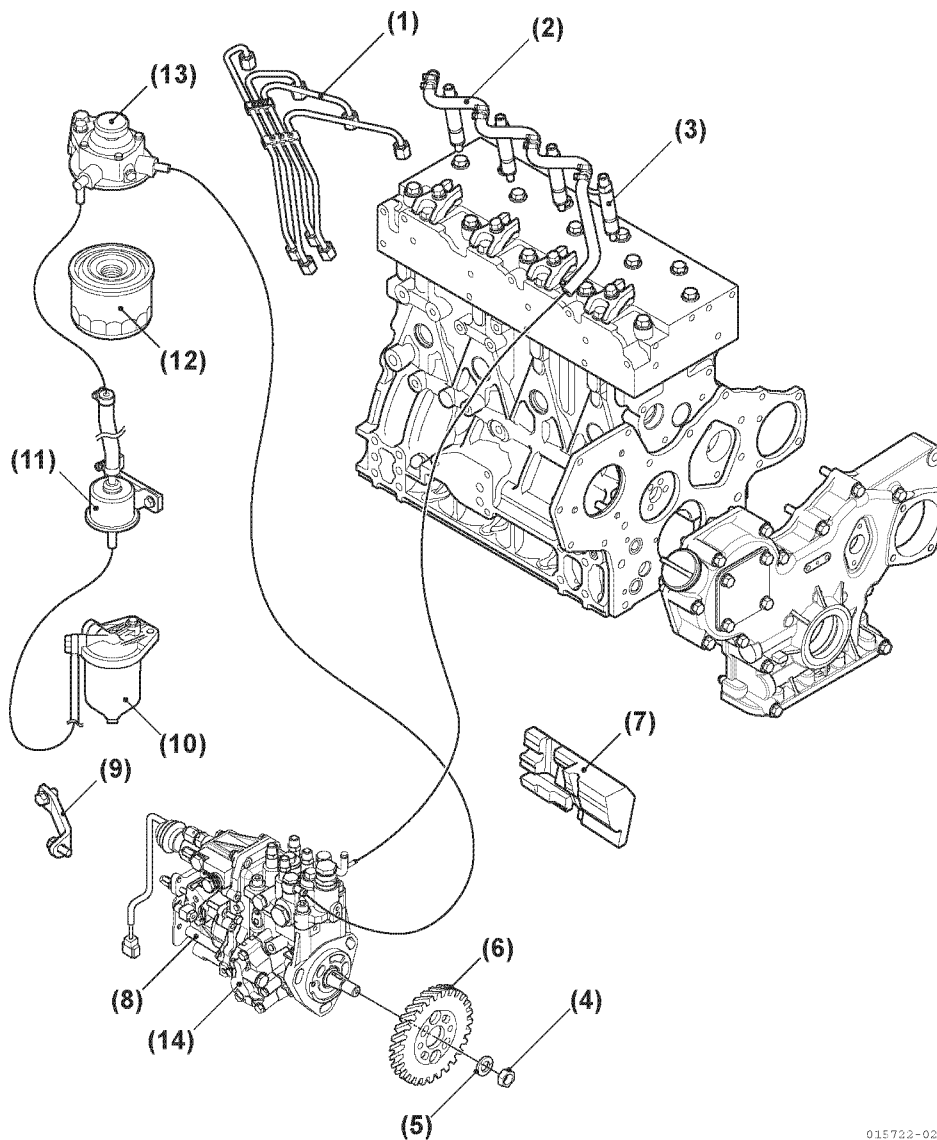

015722-02X

Figure 6-52

- | | |
|--|---|
| <ul style="list-style-type: none"> 1 – High-Pressure Fuel Injection Lines 2 – Fuel Return Line 3 – Fuel Injector 4 – Fuel Injection Pump Drive Gear Nut 5 – Lock Washer 6 – Fuel Injection Pump Drive Gear Assembly
(DO NOT remove or loosen the four bolts
that fasten the injection pump drive gear to
the injection pump drive gear hub!) | <ul style="list-style-type: none"> 7 – Fuel Injection Pump Insulator 8 – Fuel Injection Pump 9 – Rear Fuel Injection Pump Support 10 – Fuel Filter / Water Separator 11 – Electric Fuel Feed Pump 12 – Fuel Filter 13 – Fuel Filter Housing with Priming Pump 14 – Trochoid Fuel Pump |
|--|---|

FUEL INJECTION PUMP

Fuel Injection Pump Removal

1. Loosen the cooling pump V-belt.
2. Remove the spacer, V-pulley (**Figure 6-53, (1)**) and cooling fan V-belt (**Figure 6-53, (2)**).

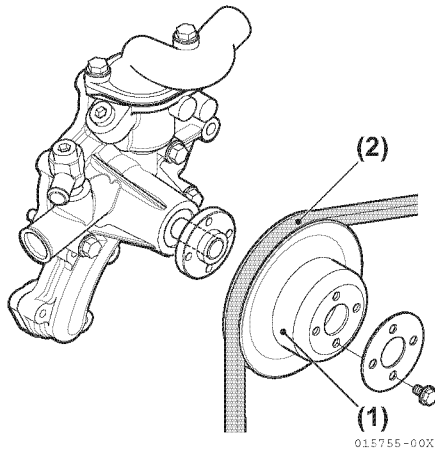

Figure 6-53

3. Close any fuel valves in the fuel supply line.
4. Place a drain pan under the fuel injection pump to catch spills.
5. Remove the high-pressure fuel injection lines as an assembly (**Figure 6-54, (1)**).

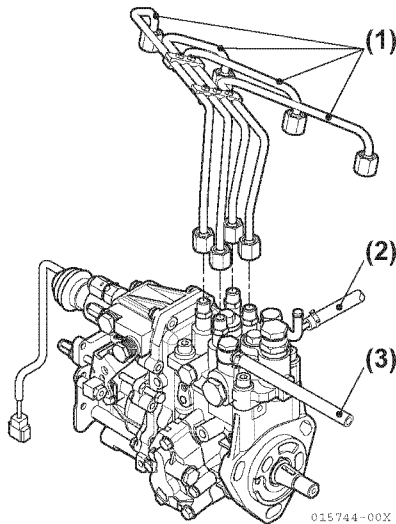

Figure 6-54

- Note: To prevent rounding the fuel line nuts always use a line or flare nut wrench. When loosening the fuel line nuts, always hold the fuel injection pump delivery valves with a “back up” wrench to prevent loosening the delivery valves.
6. First loosen the fuel line nuts at the fuel injectors and then at the fuel injection pump. *NOTICE: Remove or install the high-pressure fuel injection lines as an assembly . Disassembling the high-pressure fuel injection lines from the retainers or bending any of the fuel lines will make it difficult to reinstall the fuel lines.*
 7. Finish loosening all the fuel line nuts and remove the high-pressure fuel lines as an assembly being careful not to bend any of the fuel lines. Be sure to protect the fuel system from contamination by covering all open connections.
 8. Disconnect the fuel return lines from the fuel return fitting (**Figure 6-54, (2)**). Plug the open ends of the lines to minimize leaks and prevent contamination.
 9. Remove the fuel supply line (**Figure 6-54, (3)**). Plug the open end of the line to minimize leakage and prevent contamination.
 10. Remove the throttle cable from the fuel injection pump.

11. Separate the stop solenoid wiring connector (Figure 6-55, (2)).

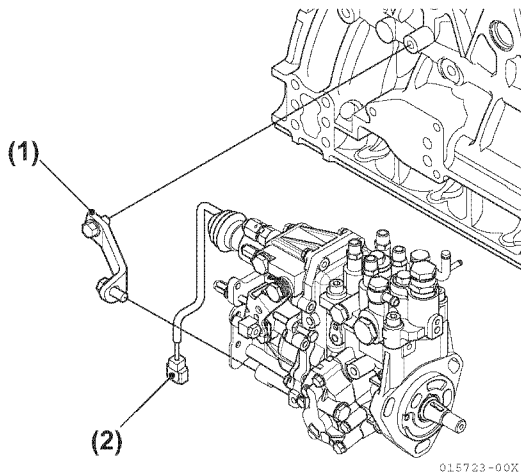

Figure 6-55

12. Remove the rear fuel injection pump bracket (Figure 6-55, (1)) from the fuel injection pump.
13. Disconnect the lubricating oil line (Figure 6-56, (1)) and the clamp (Figure 6-56, (2)) from the pump. **NOTICE:** Take care not to damage or bend the oil line. For 4JH4AE models, it may be preferable to remove the complete oil line assembly from the engine before proceeding.

Note: On 4JH4AE models, the fuel injection pump drive gear cover is attached to the gear case cover by four bolts.

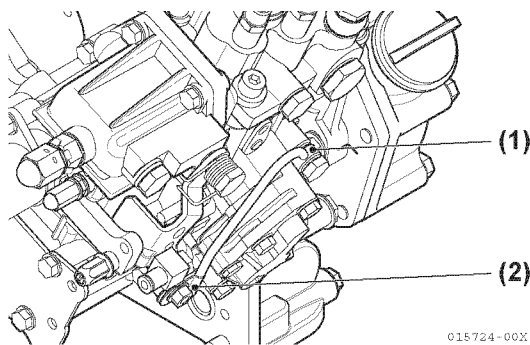

Figure 6-56

14. Remove the fuel injection pump drive gear cover (Figure 6-57, (1)) from the gear case cover (Figure 6-57, (2)).

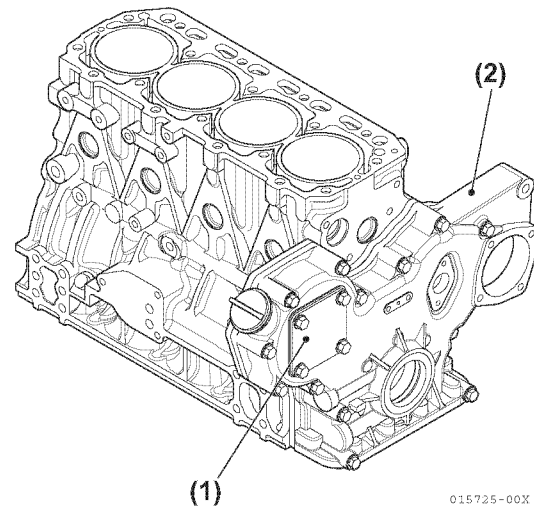

Figure 6-57

15. To position the fuel injection pump for easier removal and installation, install a dial indicator (See Checking and Adjusting Fuel Injection Timing on page 6-58) into the injection pump plunger opening. Using a wrench on the crankshaft pulley bolt, rotate the crankshaft until the dial indicator shows that the injection pump plunger is at the bottom of it's stroke.
16. To aid in reassembly, make reference marks on the fuel injection pump drive gear, and on the gear case cover or idler gear. **NOTICE:** After marking the position of the pump drive gear, do not rotate the engine crankshaft. Rotating the crankshaft will cause the fuel injection pump to become misaligned.

- On 4JH4AE models, the idler gear is not visible. Make a reference mark on the fuel injection pump drive gear (**Figure 6-58, (1)**) and a matching mark on the bore of the gear case opening (**Figure 6-58, (2)**). **CAUTION! Do not loosen or remove the four bolts retaining the fuel injection pump drive gear to the fuel injection pump hub. Do not disassemble the fuel injection pump drive gear from the hub. Correct fuel injection timing will be very difficult or impossible to achieve.**

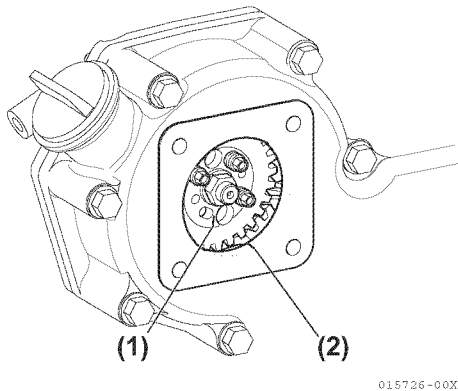

Figure 6-58

- Do not loosen or remove the four bolts (**Figure 6-59, (3)**) retaining the pump drive gear to the hub. Only remove the single drive gear nut (**Figure 6-59, (1)**) and washer (**Figure 6-59, (2)**), leaving the hub attached to the gear.

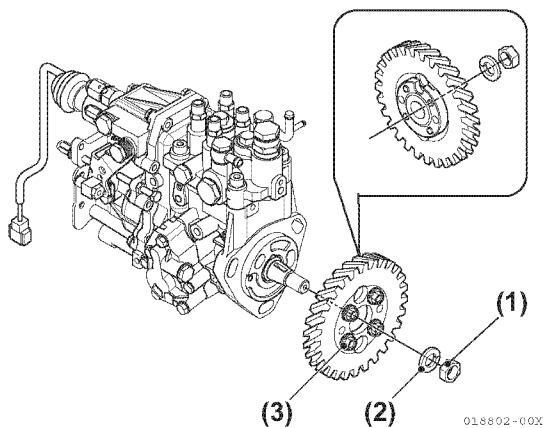

Figure 6-59

- Hold the gear train using a large socket wrench on the crankshaft pulley nut. Loosen the fuel injection pump drive gear retaining nut (**Figure 6-59, (1)**) and turn it out to the end of the fuel injection pump shaft.
- Disconnect the injection pump from drive gear as an assembly using an appropriate two-bolt gear puller (**Figure 6-60**).

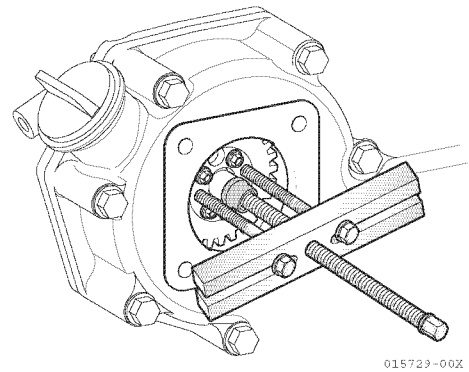

Figure 6-60

Note: On 4JH4AE models the injection pump drive gear will remain “captured” inside the gear case and will not be removable.

- Once the fuel injection pump drive gear and hub assembly has “popped” loose from the tapered fuel injection pump driveshaft, carefully remove the drive gear nut (**Figure 6-61, (1)**) and lock washer (**Figure 6-61, (2)**).

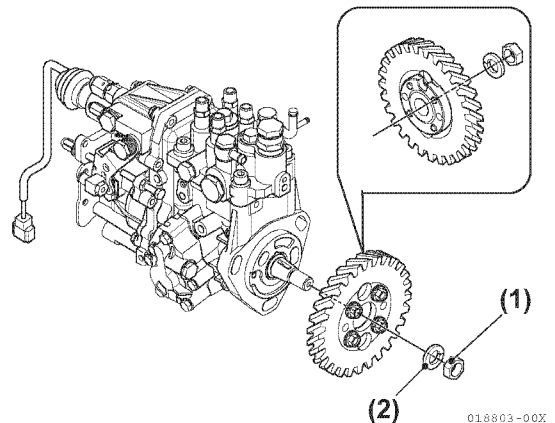

Figure 6-61

21. Locate the mark stamped into the upper outside mounting boss of the fuel injection pump. Highlight this mark and make a corresponding mark on the gear case (**Figure 6-62, (1)**).

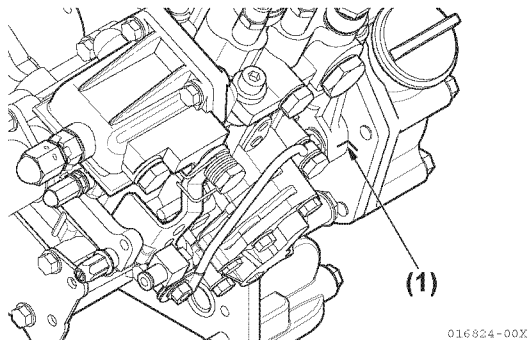

Figure 6-62

Note: It may be required that the intake manifold and fuel injection pump insulator (**Figure 6-63, (2)**) be removed to access the inner fuel injection pump (**Figure 6-63, (1)**) retaining nuts.

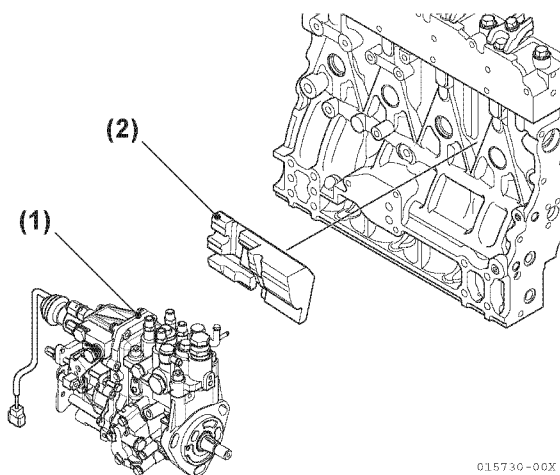

Figure 6-63

22. If required, remove the intake manifold and fuel pump insulator to access the fuel injection pump mounting nuts.

Note: The MP2 fuel injection pumps are fastened to the gear case with three studs and nuts.

23. Remove the fuel injection pump (**Figure 6-63, (1)**). For purposes of future injection timing purposes, record the fuel injection pump timing index number located on the boss on the engine side (back) of the fuel injection pump (**Figure 6-64, (1)**). **NOTICE:** Do not rotate the crankshaft while the injection pump is removed.

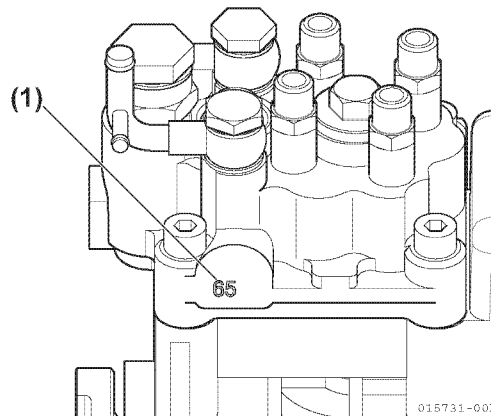

Figure 6-64

24. If the fuel injection pump requires servicing, it must be sent to an authorized Yanmar FIE repair facility for repair and calibration, or replaced with a new fuel injection pump.

CAUTION! NEVER remove or attempt to remove the tamper-proof devices from the full-load fuel adjusting screw or the high-speed throttle limit screw on the fuel injection pump and governor assembly. These adjustments have been made at the factory to meet all applicable emissions regulations and then sealed.

CAUTION! NEVER attempt to make any adjustments to these sealed adjustment screws. If adjustments are required, they should be made only by a qualified fuel injection shop that will ensure the injection pump continues to meet all applicable emissions regulations and then replace the tamper-proof seals.

CAUTION! Tampering with or removing these devices may void the "Yanmar Limited Warranty."

Fuel Injection Pump Installation

NOTICE: If installing a new or recalibrated fuel injection pump, record the timing index number located on the pump housing boss on the engine side of the new or recalibrated fuel injection pump (**Figure 6-65, (1)**). This number will be used to calculate and adjust the final fuel injection timing.

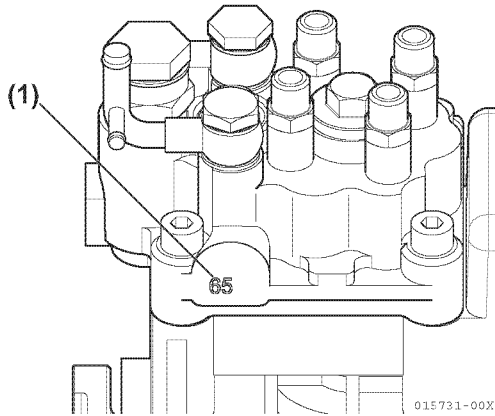

Figure 6-65

Note: If either or both of the fuel injection pumps do not have a timing index number, note the injection pump ID (example: XK42) on the injection pump ID label.

To locate the timing index number for the engine being serviced use the Timing Index Chart under “FIE Specs” on the Yanmar Distributor Website (<http://distributor.yanmar.co.jp>).

Note: Treat the timing index number as if it has a decimal point (65 = 6.5).

1. Align the pump drive gear with the idler gear using the reference marks made earlier (**Figure 6-66, (1)**).

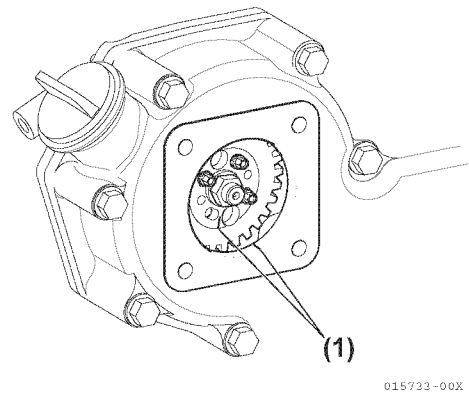
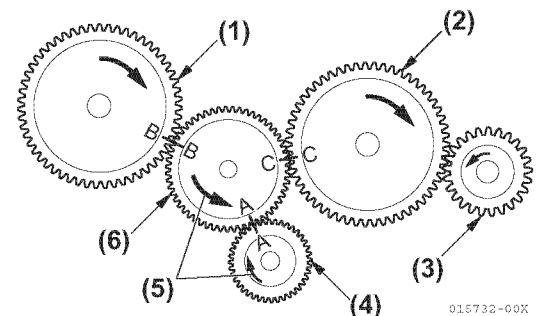

Figure 6-66

2. If installing the fuel injection pump on an engine with the front gear case cover removed, the fuel injection pump drive gear can be aligned with the idler gear by aligning the stamped marks (**A, B, C**) on the fuel injection pump drive gear, idler gear and crankshaft drive gear. Ensure all three timing marks (**Figure 6-67, (A, B, C)**) are aligned.



- 1 – Fuel Injection Pump Drive Gear
- 2 – Camshaft Drive Gear
- 3 – Seawater Pump Drive Gear
- 4 – Crankshaft Drive Gear
- 5 – Direction of Rotation
- 6 – Idler Gear

Figure 6-67

3. Install a new O-ring on the pump mounting flange. Apply grease to the O-ring to hold it in place while the injection pump is installed.

Note: Ensure the tapered surface of the fuel injection pump shaft is clean and dry.

4. Align the key on the fuel injection pump shaft with the keyway in the fuel injection pump drive gear hub. Reinstall the fuel injection pump into the fuel injection pump drive gear and gear housing. Reinstall the pump retaining nuts finger tight.
5. Reinstall the fuel injection pump drive gear lock washer (Figure 6-68, (2)) and nut (Figure 6-68, (1)). Do not lubricate the threads of the nut or shaft. Hold the crankshaft pulley bolt with a socket wrench and tighten the drive gear nut to the specified torque. See *Special Torque Chart* on page 6-43.

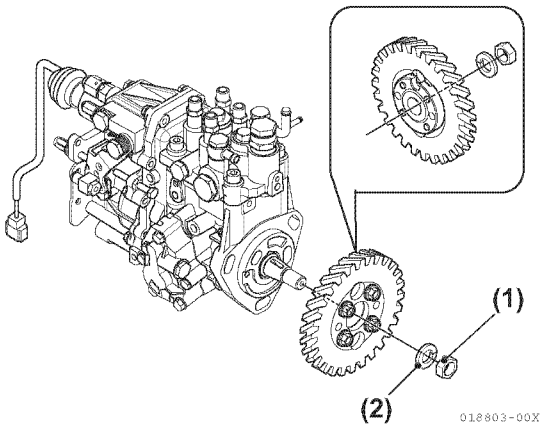

Figure 6-68

If reinstalling the original fuel injection pump:

- Align the reference marks (Figure 6-69, (1)) previously made on both the fuel injection pump mounting flange and gear case or front plate.

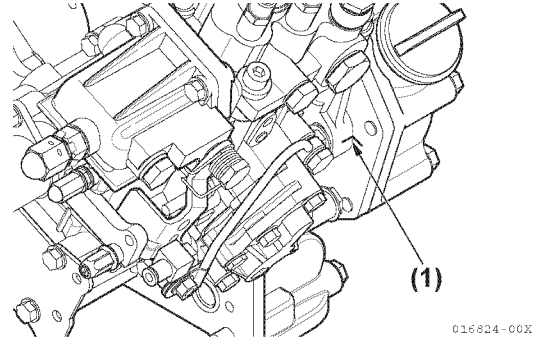

Figure 6-69

- Tighten the fuel injection pump retaining nuts to specification. See *Special Torque Chart* on page 6-43.

If installing a new fuel injection pump:

- Reinstall the timing grid sticker, provided with the new fuel injection pump, onto the back of the gear case / front plate (Figure 6-70). Align the “standard mark” (Figure 6-70, (1)) with the reference mark (Figure 6-70, (2)) made on the gear case during disassembly.

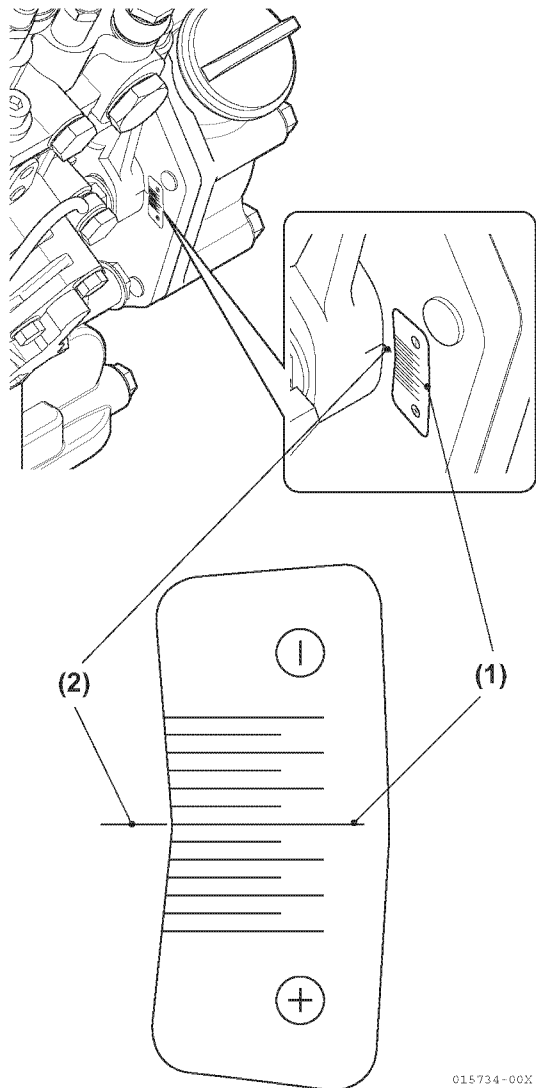

Figure 6-70

- Calculate the difference between the timing index numbers (Figure 6-71, (1)) of the fuel injection pump that you removed and the replacement fuel injection pump. See Calculation Example below.

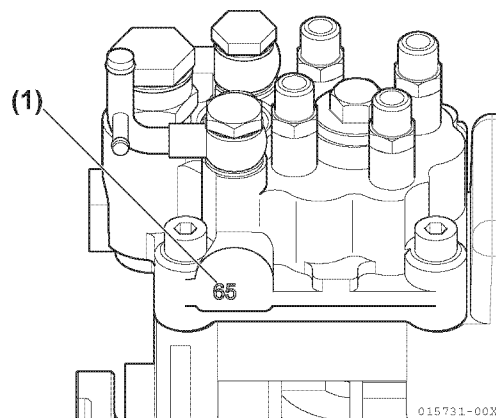

Figure 6-71

Adjusting the fuel injection timing to compensate for the difference in pump timing index numbers:

Calculation Example

Timing Index Number	
Original injection pump=	6.8
Replacement injection pump=	7.3
Difference=	+0.5

Difference = Replacement injection pump timing index number - original injection pump timing index number.

- If the difference between the timing index numbers is a positive (+) number, the fuel injection pump mounting position must be advanced (**Figure 6-72, (2)**) (rotated away from the engine) as compared to the “standard mark” (**Figure 6-72, (1)**) by the calculated positive (+) amount, adjust the fuel injection pump to the calculated value.

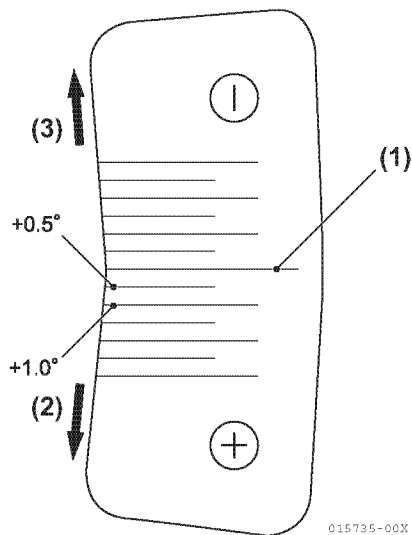

Figure 6-72

- If the difference between the timing index numbers is a negative (-) number, the replacement injection pump must be retarded (**Figure 6-72, (3)**) (rotated toward the engine) by the calculated negative (-) amount.
- Each mark on the timing sticker represents 0.5° timing change.

The above calculated difference indicates that the replacement fuel injection pump is to be installed at +0.5° (advanced) from the “standard mark” (**Figure 6-72, (1)**) on the timing sticker.

In this case, rotate the top of the fuel injection pump away from the cylinder block until the mark on the outside upper mounting boss (**Figure 6-73, (1)**) of the fuel injection pump aligns with the +0.5° mark on the timing sticker.

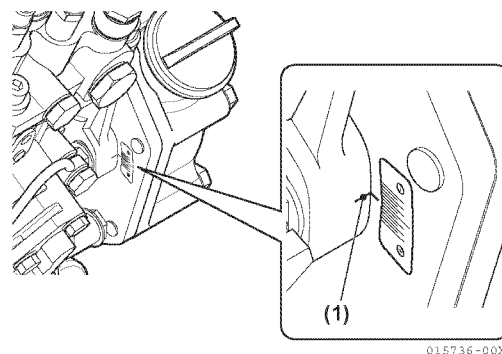

Figure 6-73

Tighten the fuel injection pump mounting nuts to specification. See *Special Torque Chart* on page 6-43.

6. Reinstall the rear bracket (**Figure 6-74, (1)**) to the fuel injection pump. Tighten the rear support bolts.

Note: Configuration of the fuel injection pump rear brackets may vary depending on the model.

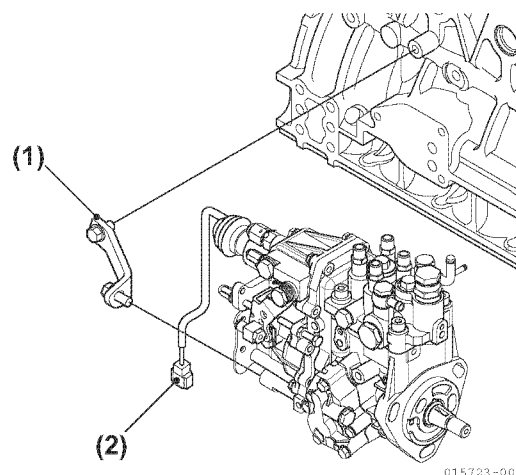

Figure 6-74

7. Reconnect the throttle linkage and the stop solenoid connector **(Figure 6-74, (2))**.
8. Reconnect the lubricating oil line **(Figure 6-75, (1))** and clamp **(Figure 6-75, (2))**.

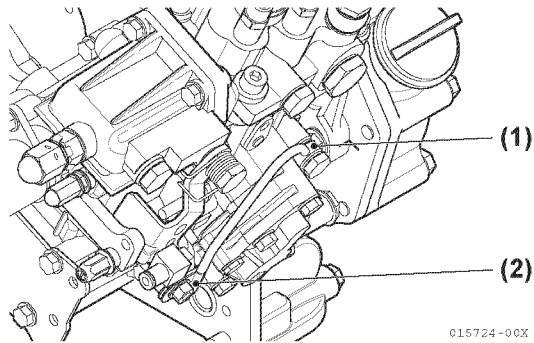

Figure 6-75

9. Apply Three Bond Liquid Gasket No. 1212, Yanmar P/N 977770-01212, or equivalent sealant to the sealing surface of the pump cover. Install the pump cover and tighten the cover bolts.
10. Reconnect the fuel return lines, fuel supply line to the fuel injection pump.
11. Reinstall the fuel injection high-pressure lines. Tighten the nuts to specification. *See Special Torque Chart on page 6-43. NOTICE: When reinstalling a new or repaired fuel injection pump, it is important to add engine oil to the fuel injection pump to provide lubrication for initial start-up. Add 5-7 oz (150-200 cc) of clean engine oil to the fuel injection pump at the fill plug located in the upper outside section of the governor housing.*

12. Verify the fuel injection pump insulator **(Figure 6-76, (2))** is not damaged, if equipped. Reinstall the insulator and intake manifold if previously removed.

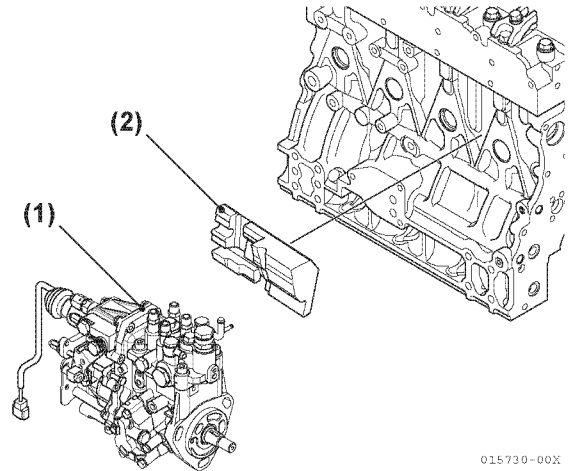

Figure 6-76

13. Reinstall the coolant pump V-pulley **(Figure 6-77, (1))**, spacer.

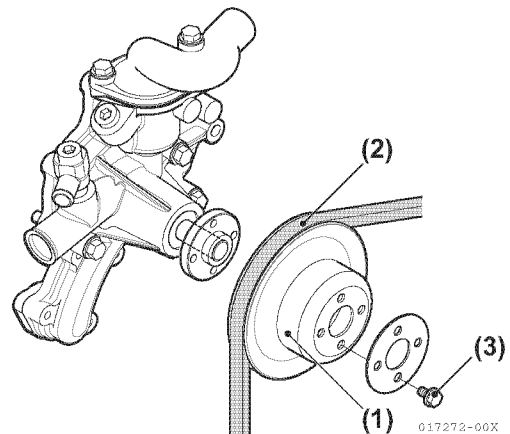

Figure 6-77

14. Reinstall the cooling pump V-belt **(Figure 6-77, (2))**. *See Replace Coolant Pump Belt and Pulley on page 7-23.*
15. Prime the fuel system. *See Bleeding the Fuel System on page 6-40.*
16. Start the engine and check for fuel and coolant leaks. **WARNING! NEVER check for fuel leaks with your hand.**

CHECKING AND ADJUSTING FUEL INJECTION TIMING

Determining the Fuel Injection Timing Specification

17. Locate and record the fuel injection pump timing index number (**Figure 6-79, (1)**) stamped into the boss on the engine side of the fuel injection pump housing (**Figure 6-78, (1)**).

Note: Treat the timing index number as if it has a decimal point (65 = 6.5).

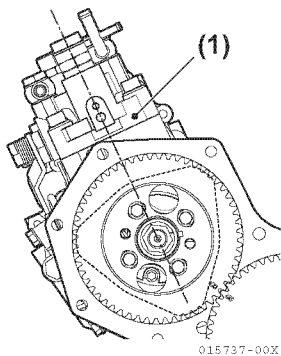

Figure 6-78

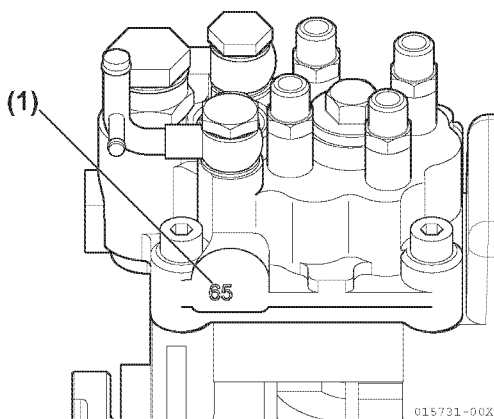

Figure 6-79

18. Using the FIR number for the engine being serviced use the Fuel Injection Reference (FIR) Chart under "FIE Specs" on the Yanmar Distributor Website (<http://distributor.yanmar.co.jp>).

The FIR number is determined by the complete engine model number. The engine model number is located on the engine nameplate (**Figure 6-80**).

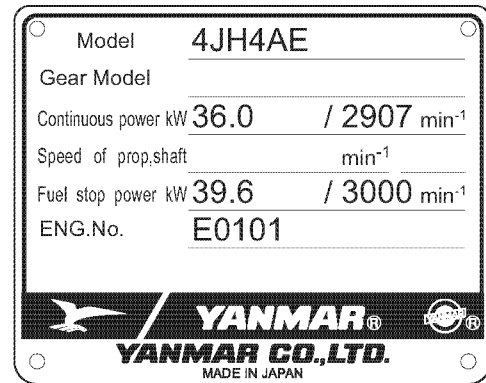

Figure 6-80

EXAMPLE: The following example is for a model 4JH4AE engine.

- Find the engine model number in the FIR chart. Locate and record the FIR number (The FIR number for this engine is 5).
- Insert the numbers you have recorded into the following equation:

(Fuel Injection Pump Timing Index Number x 2) + FIR Number = FIT° (Fuel injection Timing in Degrees)

(6.5 x 2) = 13 + 5 = 18° Fuel injection Timing

- Record the calculated fuel injection timing specification.

Checking Fuel Injection Timing

Note: Some fuel may drain from the fuel injection pump during this process. Make provisions to contain any such spillage.

1. Close off the fuel valve in the fuel supply hose and the fuel return hose.
2. Clamp shut the fuel injection pump fuel return hose (**Figure 6-81, (1)**). *NOTICE: Clean the top of the fuel injection pump to prevent any contamination when the fuel injection pump plunger plug is removed.*

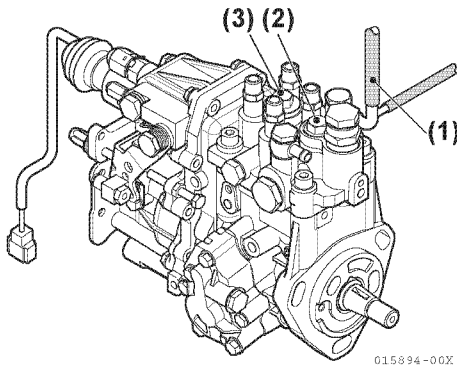

Figure 6-81

3. Remove the forward fuel injection pump plunger plug (**Figure 6-81, (2)**) on the top of the fuel injection pump. *NOTICE: Do not release the distributor plug (**Figure 6-81, (3)**). Fuel injection order may change from the proper order.*

4. Install a dial indicator adapter and clamp into the pump plunger opening.

Note: Use the Yanmar part no. 158090-51831 M14 adapter for the MP2 fuel injection pumps and Yanmar part no. 23000-013000 plunger adapter clamp (**Figure 6-82, (1)**).

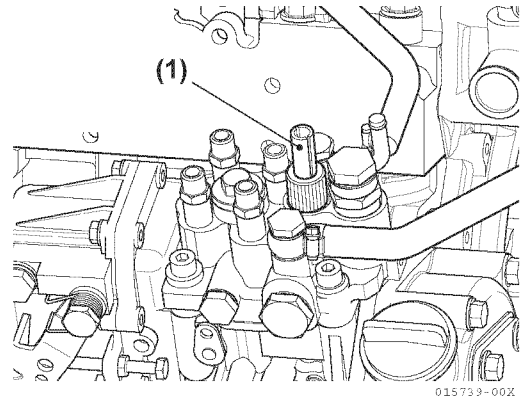

Figure 6-82

5. Install a dial indicator (**Figure 6-83, (1)**), Mitutoyo P/N 2050SB or equivalent, with a 30 mm extension, Yanmar P/N 158090-51870 or Mitutoyo P/N 303613, into the adapter. Secure with the Yanmar P/N 23000-013000 plunger adapter clamp (**Figure 6-82, (1)**) at approximately the mid-point of its travel.

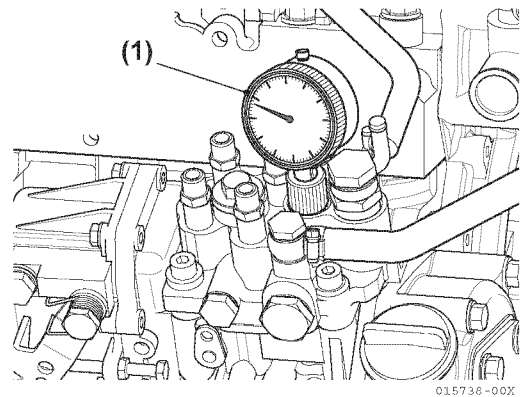

Figure 6-83

Note: The following references to the direction-of-rotation are facing the coolant pump end of the engine and are adjusted by turning the crankshaft pulley.

- Using a wrench on the crankshaft pulley bolt, rotate the crankshaft in a clockwise direction while looking through the flywheel inspection port (**Figure 6-84, (1)**). Rotate the crankshaft until the injection timing marks on the flywheel are visible.

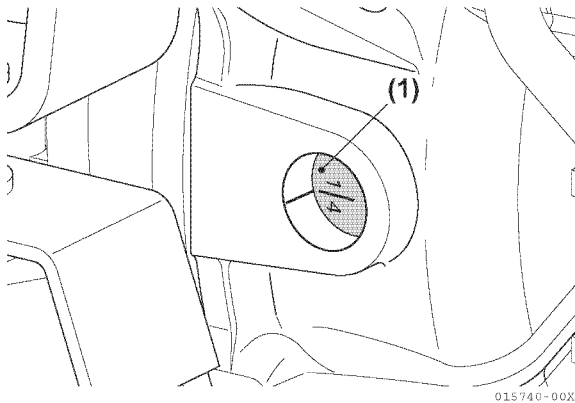
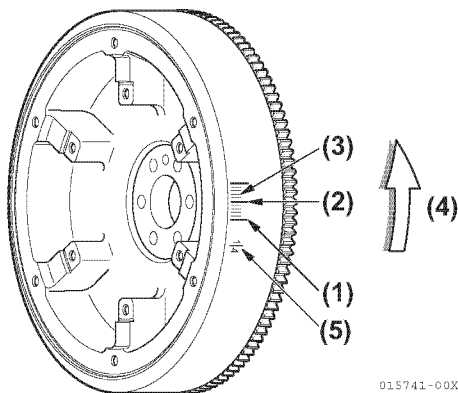

Figure 6-84

- Typical flywheel markings are as shown in (**Figure 6-85, (1)**).



- 1 – 10° BTDC (Before Top Dead Center)
- 2 – 15° BTDC
- 3 – 18° BTDC
- 4 – Direction of Rotation
- 5 – TDC (Top Dead Center)

Figure 6-85

Note: A typical flywheel will have multiple timing grids depending on the number of cylinders. Any grid can be used to check the fuel injection timing.

The flywheel shown in (**Figure 6-85**) is for a Yanmar standard specification DI engine.

Note: The TDC (Top Dead Center) mark can be identified by the cylinder numbers stamped near the TDC mark on the flywheel.

- Highlight the timing reference mark (**Figure 6-86, (2)**) on the flywheel housing. Highlight the TDC mark (**Figure 6-86, (1)**) on the flywheel.

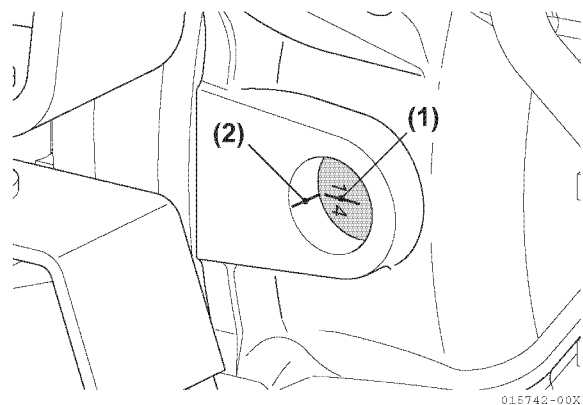

Figure 6-86

9. Highlight the target timing mark (**Figure 6-87, (1)**) on the flywheel as calculated in *Determining the Fuel Injection Timing Specification* on page 6-58. (FIT18°)

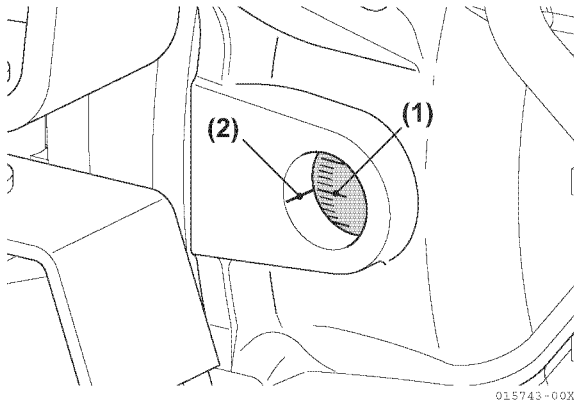

Figure 6-87

10. Rotate the crankshaft counterclockwise until the dial indicator shows that the injection pump plunger is at the bottom of its stroke. Rock the crankshaft back and forth slightly to confirm a point where the dial indicator shows no movement. Zero the dial indicator.
11. Slowly rotate the crankshaft clockwise until the dial indicator shows a pump plunger lift of 2.5 mm (0.098 in.).

12. Check the position of the previously determined flywheel target timing mark (**Figure 6-87, (1)**) in relation to the timing reference mark (**Figure 6-87, (2)**) on the flywheel housing. If the two marks are aligned, the fuel injection timing is correct. If the marks do not align, the fuel injection timing must be adjusted. See *Adjusting Fuel Injection Timing* on page 6-62.
13. If the injection timing is correct, remove the dial indicator and adapter. Replace the pump plunger plug and its copper gasket and tighten to specifications. Replace the flywheel inspection port cover. Open the fuel supply valve and remove the clamp from the fuel supply hose and the fuel return hose.
14. Prime the fuel system. Start the engine and check for leaks. **WARNING! NEVER check for fuel leaks with your hand.**

Adjusting Fuel Injection Timing

If the timing marks did not align when performing the *Checking Fuel Injection Timing* on page 6-59, the following steps must be performed to properly time the engine.

1. Leave the dial indicator installed in the fuel injection pump. Do not disturb the reading on the dial indicator.
2. Rotate the flywheel until the target timing mark (**Figure 6-88, (1)**) and the timing reference mark (**Figure 6-88, (2)**) on the flywheel housing are aligned. **NOTICE:** Do not rotate the crankshaft during the remainder of this procedure.

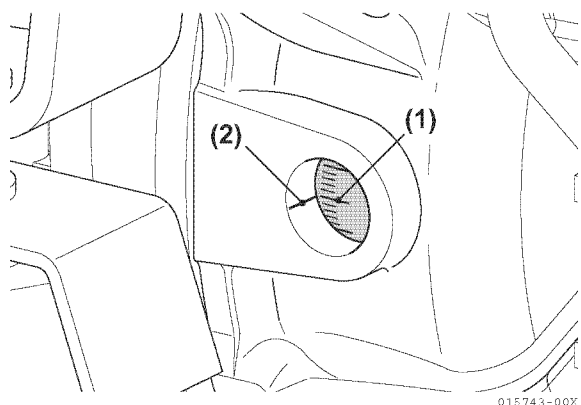

Figure 6-88

3. Note the reading on the dial indicator (**Figure 6-89, (1)**). If the reading is less than 2.5 mm (0.098 in.), the fuel injection timing is retarded. If the dial indicator reading is greater than 2.5 mm (0.098 in.), the fuel injection timing is advanced.

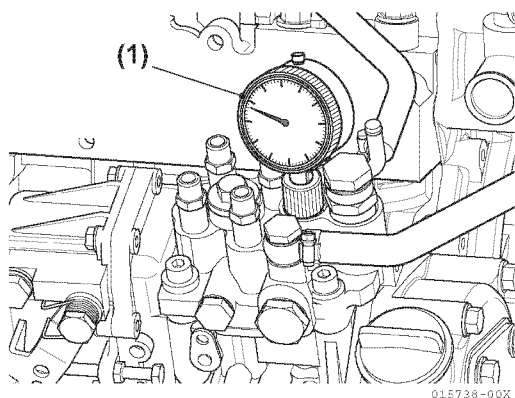

Figure 6-89

Note: Remove the intake manifold and the fuel injection pump insulator on the 4JH4AE model to access the inner fuel injection pump retaining nuts.

4. Loosen the nuts fastening the fuel injection pump to the gear case or front plate. Loosen the rear bracket(s) on the fuel injection pump.

Note: Loosening the high-pressure injection pipe nuts on the fuel injection pump may make rotating the pump easier.

5. Rotate the fuel injection pump until the dial indicator reads 2.5 mm (0.098 in.).
6. To advance the injection timing, rotate the top of the fuel injection pump away from the engine.
7. To retard the injection timing, rotate the top of the fuel injection pump toward the engine.
8. The injection timing is correct when the dial indicator reads 2.5 mm (0.098 in.) of pump plunger lift and the target timing mark on the flywheel aligns with the reference mark on the flywheel housing.
9. Tighten the nuts fastening the fuel injection pump and rear bracket(s).
10. Remove the dial indicator and adapter. Replace the plug in the pump plunger opening and tighten it to specification. If removed, install the intake manifold and pump insulator. Tighten the high-pressure injection pipe nuts to specification. Open the fuel supply valve, remove the clamp from the fuel return line and prime the fuel system. Start the engine and check it for leaks. **WARNING! NEVER check for fuel leaks with your hand.**

FUEL INJECTORS

Fuel Injectors Removal

See *Remove the fuel injection nozzles*; on page 5-41

Fuel Injectors Testing

Notice: Never use a steel wire brush to clean fuel injectors. Damage to the nozzle and other components is likely to result.

1. Thoroughly clean the fuel injector nozzle using clean diesel fuel and a brass wire brush.
2. Visually inspect the fuel injectors and nozzle protectors for deposits or damage. Clean, repair or replace as necessary.

Note: Test the fuel injector using an injection nozzle tester. Operate the tester following the information provided by the tester manufacturer. Use clean, filtered fuel or FIE calibration fluid for the test.

3. Using the correct adapter, connect a fuel injector to a nozzle tester. Aim the fuel injector into a suitable container to catch the fuel spray.

WARNING!

- **Never point a fuel injector toward you. Since the fuel is ejected at high-pressure from the nozzle, it may penetrate the skin, resulting in injury.**
- **Never inject fuel toward a fire source. Atomized fuel is highly flammable and may cause a fire or burn skin.**

CAUTION!

- **ALWAYS wear eye protection when servicing the engine and when using compressed air or high-pressure fuel. Dust, flying debris, compressed air, pressurized fuel may injure your eyes.**
- **Failure to comply may result in minor or moderate injury.**

4. Pump the operating lever of the tester slowly, observing the pressure reading at the point where the fuel injector begins spraying fuel (Figure 6-90).

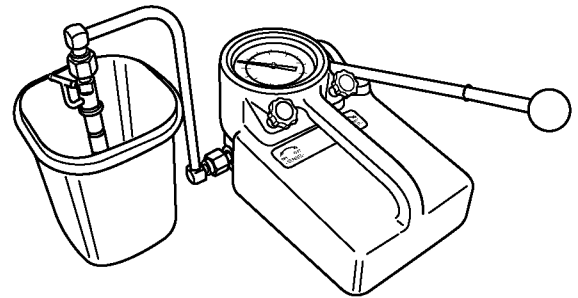

Figure 6-90

See **Figure 6-93**, for injector ID location. See *Fuel System Tests* on page 6-12 for correct pressure readings.

- Note: The opening pressure of a new fuel injector will be approximately 725 psi (5 MPa; 51 kgf/cm²) higher than one that has been operated for five hours or longer.
5. Pump the operating lever slowly to hold the pressure steady at a point just below the opening pressure and hold it for 5 seconds. Observe the injector to see that it is sealing properly and is not dripping. If fuel leaks from the return line fitting, check that the nozzle case nut is tight. Service or replace the injector if fuel continues to leak from either the return line fitting or nozzle.

- Pump the operating lever more rapidly to repeatedly pop the injector and observe the spray pattern. The pattern should be a very fine uniform spray (Figure 6-91). If dripping or an uneven pattern is seen (Figure 6-92), service or replace the injector.

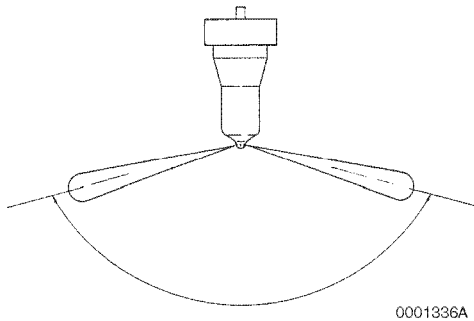

Figure 6-91

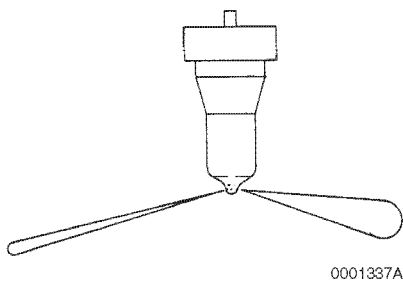

Figure 6-92

If the fuel injector fails any of these tests, it should be serviced or replaced as necessary. If the pressure is outside specified limits, adjust the pressure. See *Adjusting Fuel Injector Pressure* on page 6-65.

Fuel Injectors Disassembly and Inspection

CAUTION! Never use a steel wire brush to clean fuel injectors. Damage to the nozzle and other components is likely to result.

- Clean carbon from used injectors using clean diesel fuel. Remove hardened deposits or varnish with a brass wire brush.

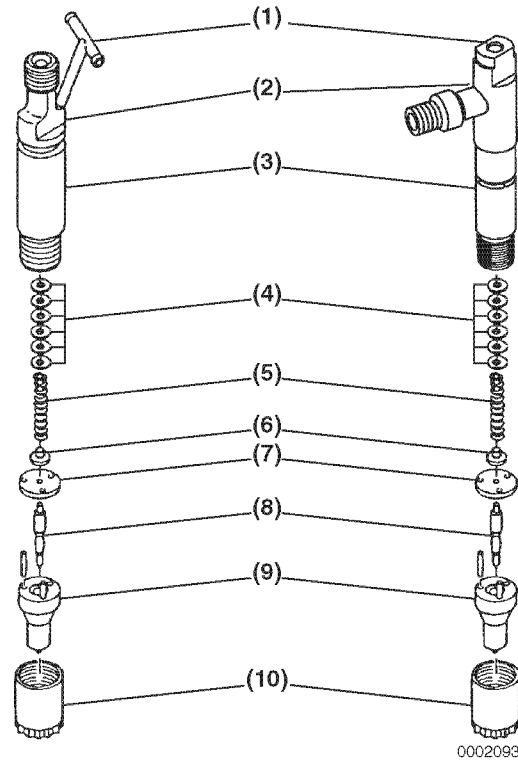

- Fuel Return Passage
- Injector ID Location
- Injector Body
- Pressure Adjusting Shims
- Spring
- Spring Seat
- Valve Stop Spacer
- Nozzle Valve
- Nozzle Body
- Nozzle Case Nut

Figure 6-93

- Place the fuel injector in a soft-jawed vise with the nozzle pointing up.
- Remove the nozzle case nut.
- Carefully remove the injector from the vise.

5. Turn the injector over and remove the nozzle body, nozzle valve, valve stop spacer, nozzle spring seat, nozzle spring and shims.
6. Inspect the sealing surfaces (**Figure 6-94, (2)**) between the valve stop spacer and nozzle body for nicks or scratches. Check the contact area between the valve stop spacer and the nozzle valve (**Figure 6-94, (1)**) for scoring, or pitting. Use a magnifier glass to inspect the area.

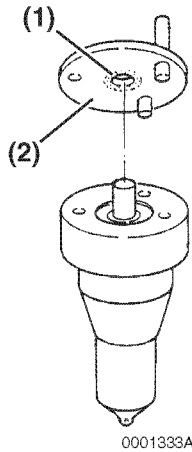

Figure 6-94

7. Perform a nozzle valve slide test:
 - (a) Wash nozzle body and valve in clean diesel fuel.
 - (b) While holding the nozzle body vertical, pull the nozzle valve about two-thirds of the way out (**Figure 6-95**).

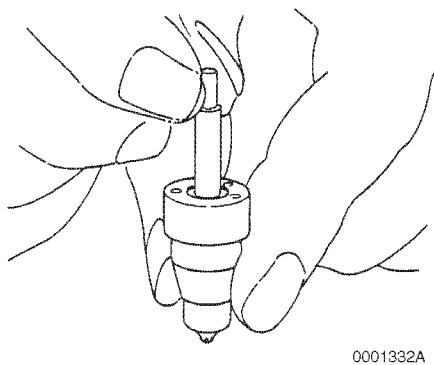

Figure 6-95

- (c) Release the valve. It should fall smoothly to its seat by its own weight.

8. Replace the fuel injector assembly if it fails any inspection.

Adjusting Fuel Injector Pressure

The fuel injectors open when pressure reaches a predetermined pressure threshold. They close when the pressure is reduced below that threshold. The pressure threshold can be adjusted by adding or removing shims (**Figure 6-96, (3)**).

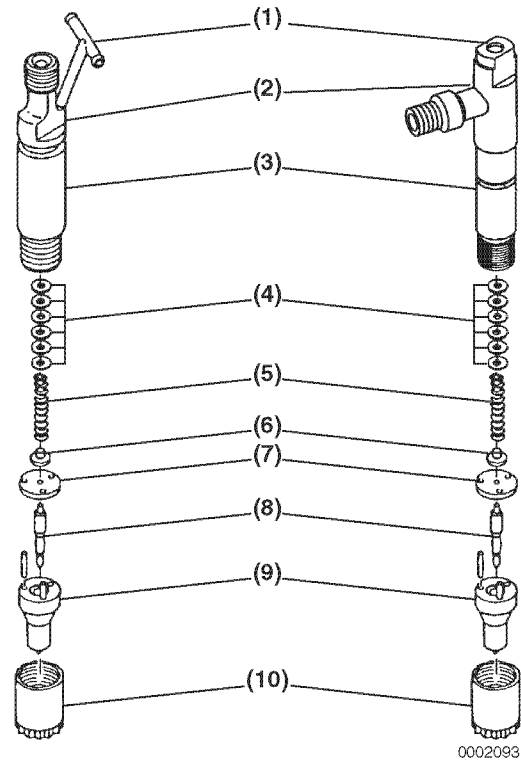

Figure 6-96

- 1 – Fuel Return Passage
- 2 – Injector ID Location
- 3 – Injector Body
- 4 – Pressure Adjusting Shims
- 5 – Spring
- 6 – Spring Seat
- 7 – Valve Stop Spacer
- 8 – Nozzle Valve
- 9 – Nozzle Body
- 10 – Nozzle Case Nut

The injection pressure will change by approximately 275 psi (1.9 MPa; 19 kgf/cm²) for every 0.1 mm (0.004 in.) in shim thickness.

See the parts catalog for available shims.

Note: Each pressure adjusting shim removed or added changes the pressure threshold by approximately 275 psi (1.9 MPa, 19 kgf/cm²). Adding adjusting shims increases the threshold pressure. Removing adjusting shims reduces the pressure threshold.

1. Disassemble the fuel injector assembly. *See Fuel Injectors Disassembly and Inspection on page 6-64.*
2. Remove or add adjusting shims as needed.
3. Reassemble the fuel injector assembly. *See Fuel Injectors Reassembly on page 6-66.*
4. Retest the fuel injector. *See Fuel Injectors Testing on page 6-63.* If the injector cannot be adjusted to the appropriate pressure, discard the fuel injector.

Fuel Injectors Reassembly

1. Secure the injector in a soft-jawed vise with the nozzle end up.
2. Reinstall the shims, nozzle spring, nozzle spring seat, valve stop spacer, nozzle valve, and nozzle body.
3. Reinstall the nozzle case nut. Tighten it to specification. *See Special Torque Chart on page 6-43. See Remove the fuel injection nozzles: on page 5-41.*

Section 7

COOLING SYSTEM

	Page
Safety Precautions	7-3
Introduction.....	7-3
Specifications	7-4
Test and Adjustment Specifications	7-4
Repair Specifications.....	7-4
Special Service Tools.....	7-5
Measuring Instruments.....	7-5
Cooling Flow Diagram	7-6
Tests and Adjustments.....	7-8
Pressure Testing Cooling System and Filler Cap.....	7-8
Test Thermostat	7-9
Drain and Refill Seawater Cooling System	7-10
Drain and Fill Closed Cooling System.....	7-13
Remove and Install Intercooler (Only for 4JH4-HTE).....	7-14
Disassemble and Assemble intercooler	7-15
Remove and Install Heat Exchanger.....	7-16
Disassemble and Assemble Heat Exchanger	7-18
Remove and Install Coolant Pump.....	7-19
Remove and Install Thermostat	7-21
Seawater Pump.....	7-22
Coolant Recovery Tank.....	7-25
Bilge Pump and Bilge Strainer (Optional).....	7-26

This Page Intentionally Left Blank

SAFETY PRECAUTIONS

Before you service the cooling system, read the following safety information and review the *Safety Section on 2-1*.

CAUTION

The safety message that follows has **CAUTION** level hazards. The safety message describes a hazardous situation which, if not avoided, *could* result in minor or moderate injury.

Coolant Hazard

 Wear eye protection and rubber gloves when you handle Long Life engine coolant. If contact with the eyes or skin should occur, flush eyes and wash immediately with clean water.

NOTICE

Indicates a situation which can cause damage to the machine, personal property and / or the environment or cause the equipment to operate improperly.

Only use the engine coolant specified. Other engine coolants may affect warranty coverage, cause an internal buildup of rust and scale and / or shorten engine life.

Prevent dirt and debris from contaminating the engine coolant. Carefully clean the filler cap and the surrounding area before you remove the cap.

NEVER mix different types of engine coolants. This may adversely affect the properties of the engine coolant.

INTRODUCTION

This section of the *Service Manual* describes the procedures necessary to service the JH4 series marine engine cooling systems.

SPECIFICATIONS

Test and Adjustment Specifications

Note: All pressure specifications are for an engine at normal operating temperature.

Inspection Item	Model	Specification			Reference Page
Cooling System Test Pressure	All	1.4 bar (20 psi)			<i>See Pressure Testing Cooling System and Filler Cap on page 7-8</i>
Filler Cap Test Pressure	All	1.4 bar (20 psi)			
Thermostat		Marking	Begins Opening	Fully Open	<i>See Test Thermostat on page 7-9</i>
	All	76.5°C (170°F)	75-78°C (167-172°F)	90°C (194°F)	

Repair Specifications

Coolant Capacity (Approximate)	3JH4E	4.5 L (4.8 qt)
	4JH4AE	6.0 L (6.3 qt)
	4JH4-TE, 4JH4-HTE	7.2 L (7.6 qt)

SPECIAL SERVICE TOOLS

Note: Tools not having part numbers must be obtained locally.

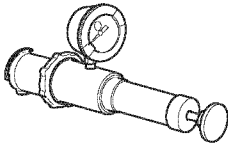
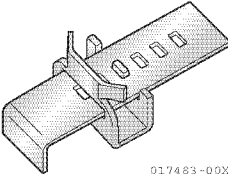
No.	Tool Name	Applicable Model and Tool Size	Illustration
1	Cooling System Tester (For pressure-testing and checking the leakage of the cooling system and filler cap)	Obtain locally	 001439-00X
2	Belt Tool (For removing and installing seawater pump belt)	-	 017483-00X

MEASURING INSTRUMENTS

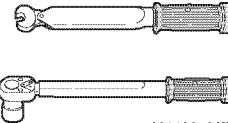
No.	Instrument Name	Application	Illustration
1	Torque Wrench	For tightening nuts and bolts to the specified torque	 001438-00X

COOLING FLOW DIAGRAM

3JH4E Engine

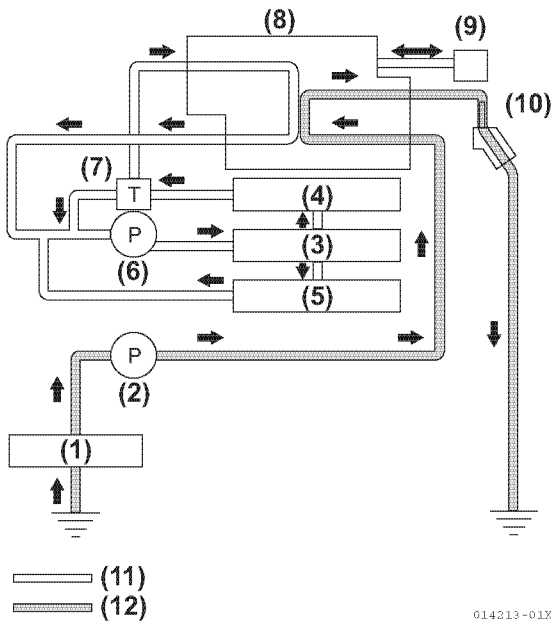

Figure 7-1

Note: Typical 3JH4E engine shown. 4JH4AE engine is similar.

- 1 – Seacock
- 2 – Seawater Pump
- 3 – Cylinder Block
- 4 – Cylinder Head
- 5 – Lubricating Oil Cooler
- 6 – Freshwater Pump
- 7 – Thermostat
- 8 – Freshwater Cooler (Heat Exchanger)
- 9 – Recovery Tank
- 10 – Mixing Elbow
- 11 – Freshwater Circuit
- 12 – Seawater Circuit

4JH4-TE Engine

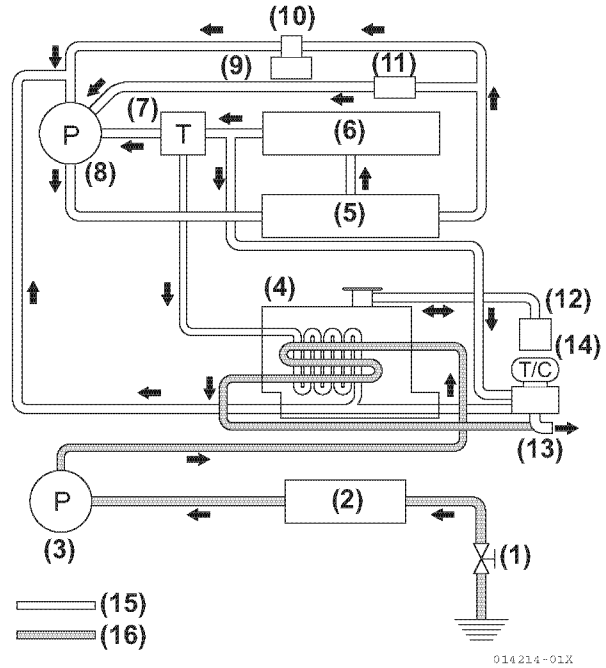

Figure 7-2

- 1 – Seacock
- 2 – Clutch Cooler
- 3 – Seawater Pump
- 4 – Freshwater Cooler (Heat Exchanger)
- 5 – Cylinder Block
- 6 – Cylinder Head
- 7 – Thermostat
- 8 – Freshwater Pump
- 9 – FO Pump
- 10 – W.CSD
- 11 – Lubricating Oil Cooler
- 12 – Recovery Tank
- 13 – Mixing Elbow
- 14 – Turbocharger
- 15 – Freshwater Circuit
- 16 – Seawater Circuit

4JH4-HTE Engine

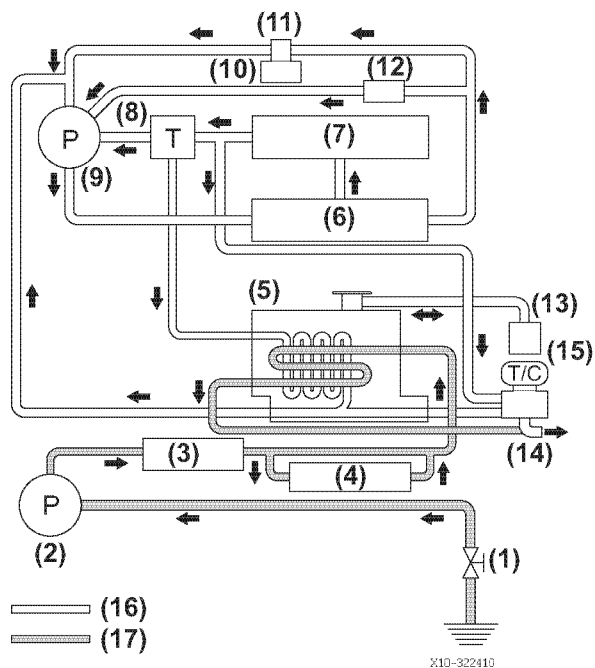

Figure 7-3

- 1 – Seacock
- 2 – Seawater Pump
- 3 – Inter Cooler
- 4 – Clutch Cooler
- 5 – Freshwater Cooler (Heat Exchanger)
- 6 – Cylinder Block
- 7 – Cylinder Head
- 8 – Thermostat
- 9 – Freshwater Pump
- 10 – FO Pump
- 11 – W.CSD
- 12 – Lubricating Oil Cooler
- 13 – Recovery Tank
- 14 – Turbocharger
- 15 – Mixing Elbow
- 16 – Freshwater Circuit
- 17 – Seawater Circuit

TESTS AND ADJUSTMENTS

Pressure Testing Cooling System and Filler Cap

Cooling System

Use a cooling system tester with connections compatible with the Yanmar JH4 series cooling system.

1. Remove the filler cap from the heat exchanger.
WARNING! NEVER remove the coolant filler cap if the engine is hot. Steam and hot engine coolant will escape and seriously burn you. Allow the engine to cool before attempting to remove the filler cap.
2. Check that the lugs and sealing flange on the filler pipe are undamaged and free of debris that will prevent a good seal.
3. Install the tester and adapter in place of the filler cap.
4. Pump until pressure is 1.45 bar (21 psi) (Figure 7-4).

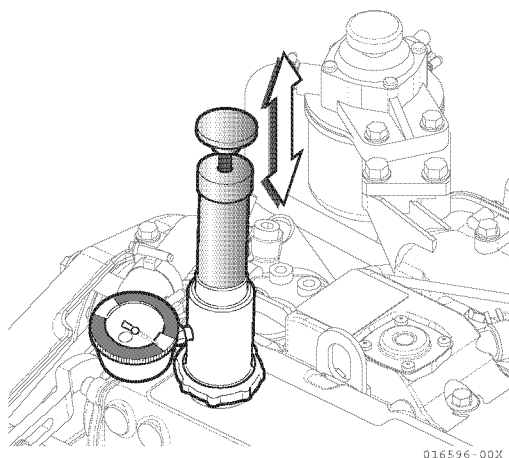

Figure 7-4

5. Pressure should hold steady. If the pressure drops, there is a leak in the system. Start by checking all hoses and pipe connections.

Filler Cap

1. Connect the cap to the cooling system tester using the adapter for the cap.
2. Pump until the cap opens (Figure 7-5).

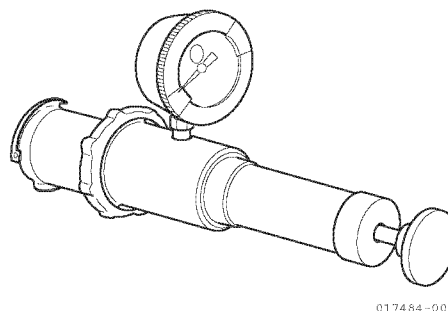

Figure 7-5

3. The tester needle should stop at approximately 1.45 bar (21 psi).

Test Thermostat

The thermostat used in this engine is of the wax pellet type, with a solid wax pellet located in a smaller chamber.

When the temperature of the coolant rises, the wax melts and increases in volume. This expansion and contraction is used to open and close the valve (Figure 7-6).

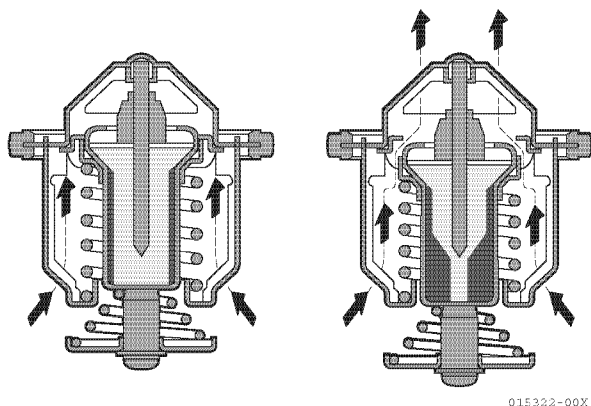

Figure 7-6

1. The design temperature for the thermostat is stamped into the thermostat body. Find and record this number.

2. Immerse the thermostat into a container of water. Suspend it so that it does not come into contact with the walls or bottom of the container (Figure 7-7).

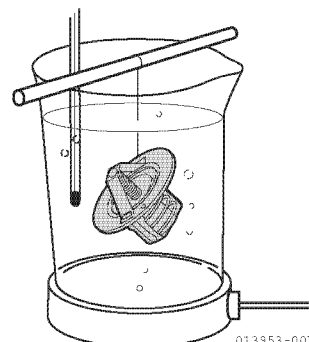

Figure 7-7

3. Slowly heat the water and monitor the temperature with a thermometer. Stir the water.
4. Check that the thermostat begins to open at the specified temperature, and that it is fully open at the temperature given in the specifications. If the test results are not within specification, replace the thermostat.

Specifications

Opening Temperature	Full Open Temperature	Valve Lift at Full Open
75-78°C (167-172°F)	90°C (194°F)	8mm or more (0.31 in.)

DRAIN AND REFILL SEAWATER COOLING SYSTEM

Note: If water fails to drain from any open drain cock or port, remove the cock completely and probe the opening with a small piece of wire to loosen debris.

1. Loosen the seawater pump cover (Figure 7-8, (3)) to allow water to drain. See *Seawater Pump* on page 7-22.

3JH4E Engine

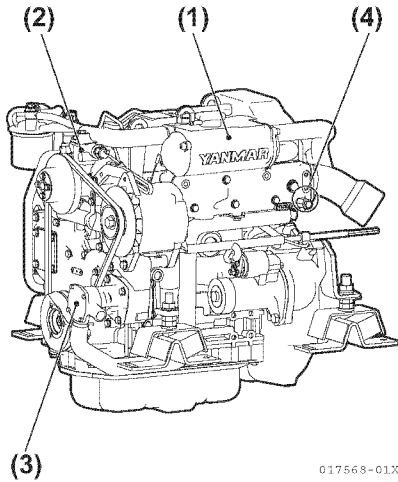

Figure 7-8

- 1 – Heat Exchanger Coolant Tank
- 2 – Freshwater Coolant Pump
- 3 – Seawater Drain from Seawater Pump Cover
- 4 – Coolant Drain Cock

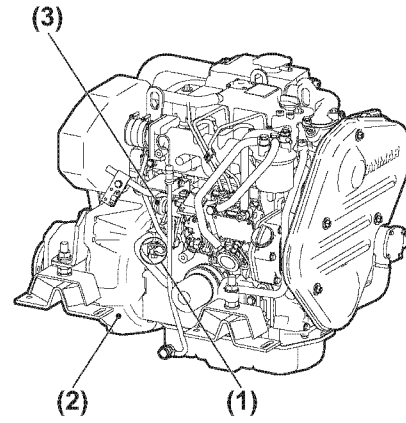

Figure 7-9

- 1 – Coolant Drain Cock
- 2 – Flywheel Housing
- 3 – Stop Solenoid

2. When water has drained, install cover and tighten bolts. *NOTICE: Be sure O-ring is in place in groove of housing.*
3. Remove zinc anodes from the engine heat exchanger and allow water to drain from housing.
4. Inspect Condition of zinc anodes and replace as necessary. See *Drain and Fill Closed Cooling System* on page 7-13.
5. Close all drain cocks.

4JH4AE Engine

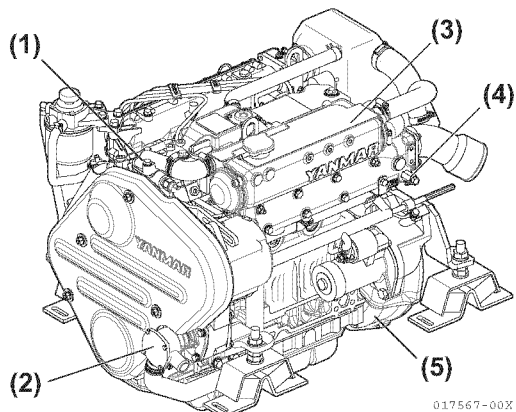

Figure 7-10

- 1 – Freshwater Coolant Pump
- 2 – Seawater Pump
- 3 – Heat Exchanger Coolant Tank
- 4 – Coolant Drain Cock
- 5 – Seawater Drain from Seawater Pump Cover

4JH4-TE Engine

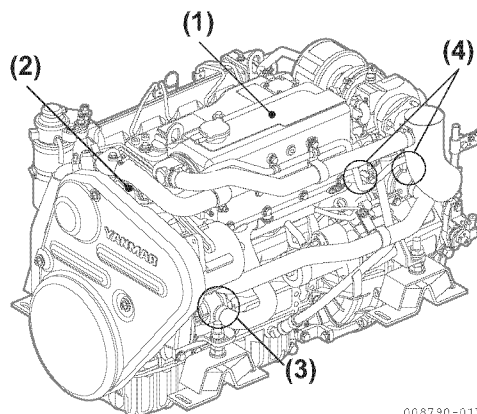

Figure 7-12

- 1 – Heat Exchanger Coolant Tank
- 2 – Freshwater Coolant Pump
- 3 – Seawater Drain from Seawater Pump Cover
- 4 – Coolant Drain Cock (2 used)

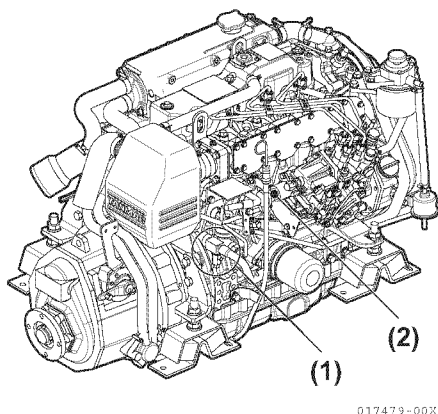

Figure 7-11

- 1 – Coolant Drain Cock
- 2 – Stop Solenoid

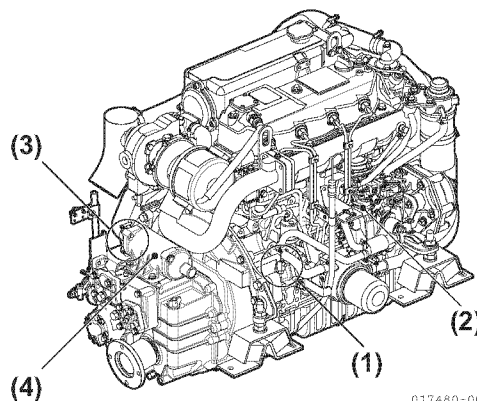

Figure 7-13

- 1 – Coolant Drain Cock
- 2 – Fuel Pump
- 3 – Seawater Drain Cock
- 4 – Marine Gear Cooler

4JH4-HTE Engine

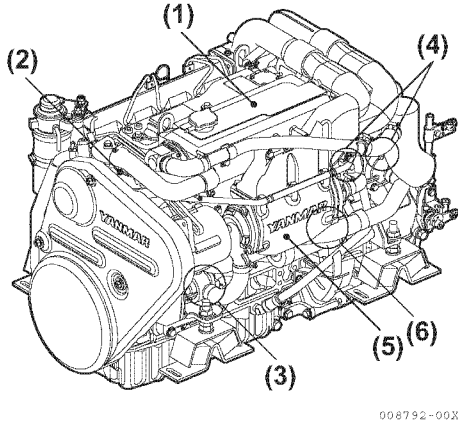

Figure 7-14

- 1 – Heat Exchanger Coolant Tank**
- 2 – Freshwater Coolant Pump**
- 3 – Seawater Drain from Seawater Pump Cover**
- 4 – Coolant Drain Cock**
- 5 – Intercooler**
- 6 – Seawater Drain from Heat Exchanger**

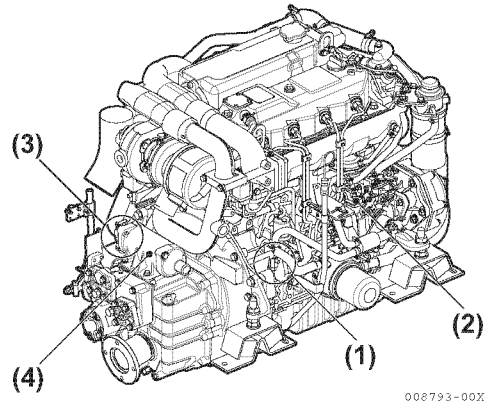

Figure 7-15

- 1 – Coolant Drain Cock**
- 2 – Fuel Pump**
- 3 – Seawater Drain Cock**
- 4 – Marine Gear Cooler**

Note: The drain cocks are opened before shipping from the factory. Marine gear ZF25A does not have a drain cock on the clutch cooler. If seawater is left inside, it may freeze and damage parts of the cooling system (freshwater cooler seawater pump, etc.) when ambient temperature is below 0°C (32°F).

Drain and Fill Closed Cooling System

1. Remove coolant filler cap (Figure 7-16, (1)) from heat exchanger (Figure 7-16, (2)).
WARNING! NEVER remove the coolant filler cap if the engine is hot. Steam and hot engine coolant will escape and seriously burn you. Allow the engine to cool before attempting to remove the filler cap.

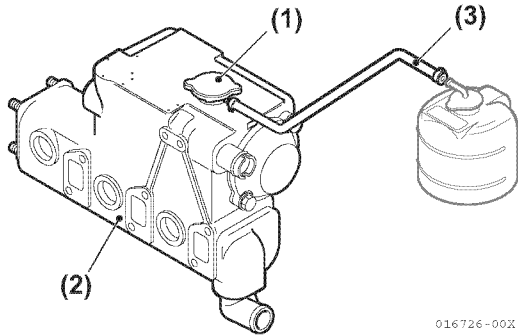

Figure 7-16

2. Inspect the cap gasket and flange on the filler neck for damage (Figure 7-17, (1)).

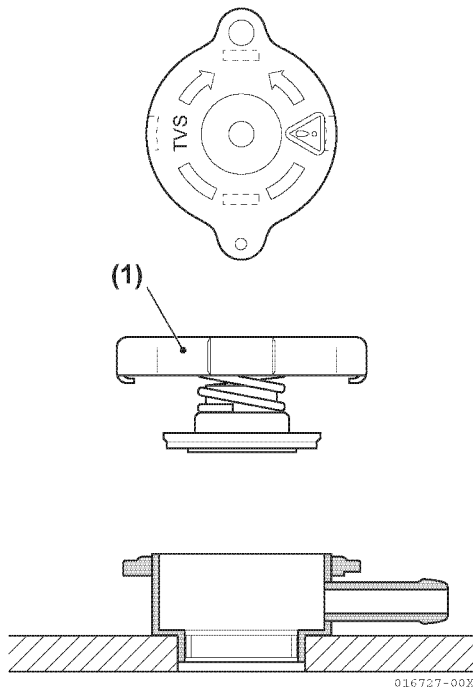

Figure 7-17

3. Check the rubber hose (Figure 7-16, (3)) connecting the coolant recovery tank to the heat exchanger. Be sure the hose is securely connected and there is no damage.
4. Pour coolant mix slowly into the heat exchanger to prevent the formation of air pockets. Fill until the heat exchanger is completely full.
5. Install the filler cap and tighten firmly.
6. Remove the coolant recovery tank cap and fill with coolant mix to approximately 50 mm (2 in.) below the full line. Replace cap. Never fill to the full mark.
7. After filling an empty cooling system, test-run the engine for approximately five minutes and recheck the engine coolant level in the coolant recovery tank.

REMOVE AND INSTALL INTERCOOLER (ONLY FOR 4JH4-HTE)

1. Drain seawater from seawater drain cock (Figure 7-18, (1)).

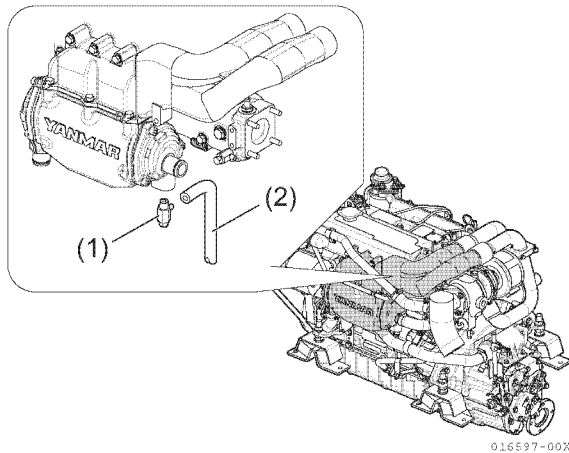

Figure 7-18

2. Remove the seawater drain pipe connected to seawater drain cock (Figure 7-18, (2)).
3. Disconnect seawater pipe between intercooler water box A and seawater pump (Figure 7-19, (1)).

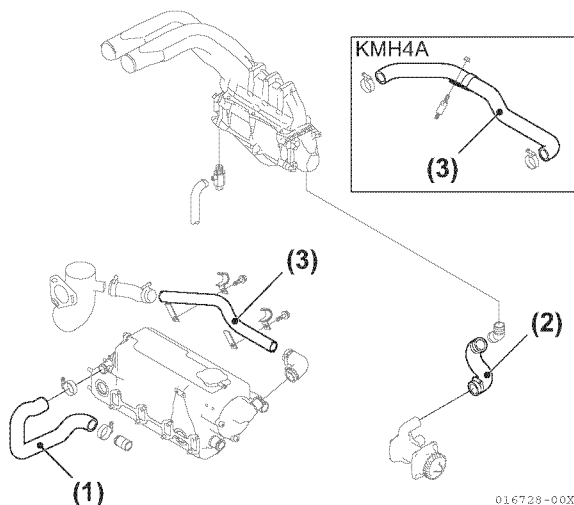

Figure 7-19

4. Disconnect cooling seawater pipe between intercooler water box B and cooling freshwater cooler (Figure 7-19, (2)).
5. Disconnect clamp bolt of pipe between mixing elbow and cooling freshwater or marine gear cooler (Figure 7-19, (3)).

6. Loosen bolts (Figure 7-20, (1)).

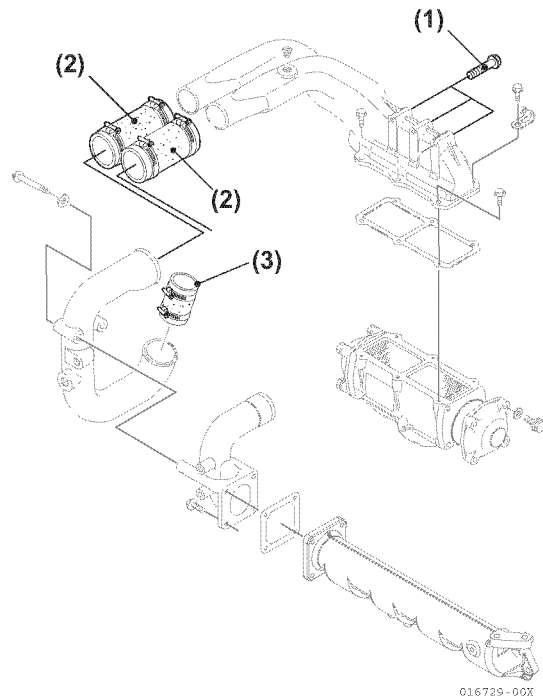

Figure 7-20

7. Remove rubber hose between air duct of intercooler and bend of intake manifold (Figure 7-20, (2)).
8. Remove rubber hose between air duct of intercooler and air duct of turbocharger (Figure 7-20, (3)).
9. Remove intercooler assembly from freshwater cooler.
10. Disassemble and repair as necessary. See *Disassemble and Assemble intercooler on page 7-15*.
11. Install intercooler.
12. Install rubber hose between air duct of intercooler and bend of intake manifold.
13. Install rubber hose between air duct of intercooler and air duct of turbocharger.
14. Connect seawater pipes to each end of intercooler.
15. Tighten clamp bolt of cooling seawater pipe to mixing elbow.
16. Connect seawater drain cock and pipe.
17. Start the engine and check for coolant and air leaks. Check the level of the coolant and fill as necessary.

DISASSEMBLE AND ASSEMBLE INTERCOOLER

1. Loosen bolts (**Figure 7-21, (1)**) and remove intercooler from cooling freshwater cooler. See *Remove the intercooler (only for 4JH4-HTE) (Figure 5-21): on page 5-36.*

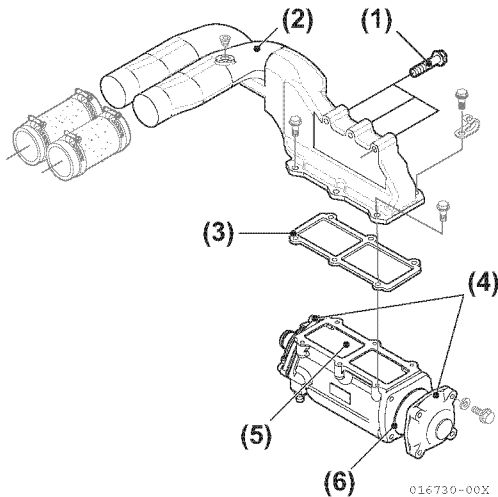

Figure 7-21

2. Remove air duct assembly (**Figure 7-21, (2)**) and gasket (**Figure 7-21, (3)**).
3. Remove water box A and B (**Figure 7-21, (4)**).
4. Disassemble, inspect, and clean intercooler assembly (**Figure 7-21, (5)**) and change as necessary. *NOTICE: NEVER use caustic soda to clean the components. Use paraffin-based engine detergent to clean the cooler element. Thoroughly flush and rinse all components.*
5. If any internal deposits remain in the tubes, consult a local radiator repair shop.

Note: Always install new O-rings.

6. Install new O-rings (**Figure 7-21, (6)**) on water boxes.
7. Install water boxes.
8. Install gasket and air duct assembly.
9. Install intercooler and tighten bolts to cooling freshwater cooler. See *4JH4-HTE: Install the inter cooler. on page 5-109.*

REMOVE AND INSTALL HEAT EXCHANGER

1. Drain coolant from the engine and heat exchanger. *See Drain and Fill Closed Cooling System on page 7-13.*
2. Drain the seawater system. *See Drain and Refill Seawater Cooling System on page 7-10.*
3. Disconnect seawater pipes (**Figure 7-22, (1)**) and (**Figure 7-22, (2)**) from heat exchanger.

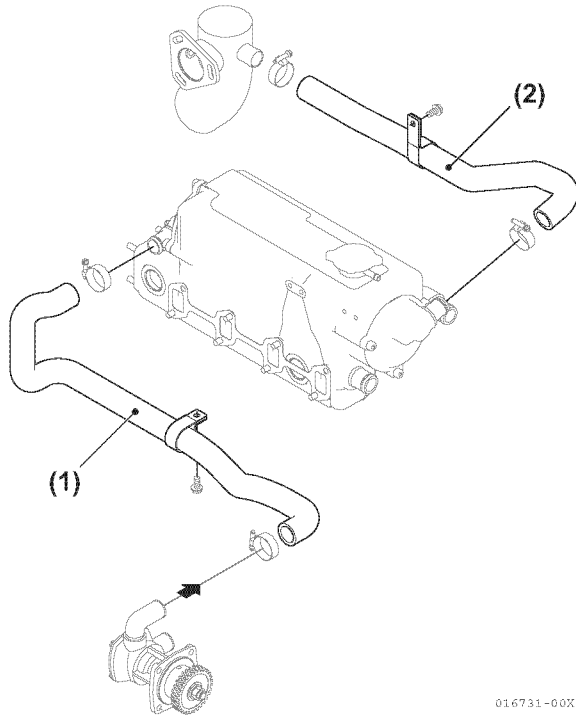

Figure 7-22

4. Remove six tightening bolts (**Figure 7-23, (1)**).

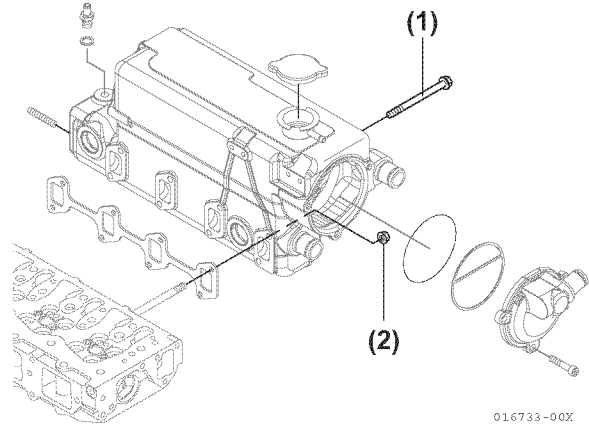

Figure 7-23

5. Loosen the two nuts on the cylinder head stud bolts (**Figure 7-23, (2)**).
6. Remove the heat exchanger.
7. The noise absorber A and B (**Figure 7-24, (1), (2)**) are installed between the heat exchanger and cylinder head for 4JH4-TE/4JH4-HTE engines. Replace if the absorber deteriorates.

Notice:

- Avoid damaging covers A and B (**Figure 7-24, (3), (4)**).
- Avoid getting lubricating oil on the noise absorber.

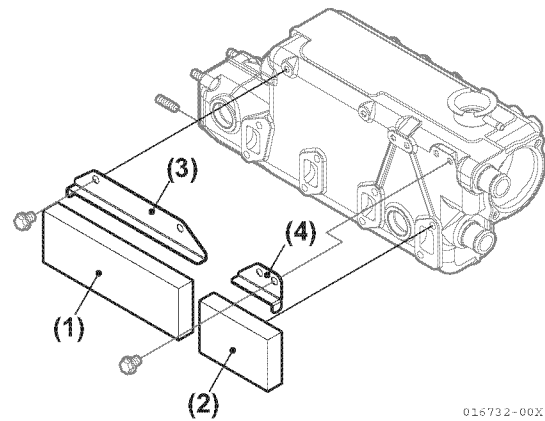

Figure 7-24

8. Disconnect, inspect, and clean heat exchanger as necessary. See *Remove the heat exchanger and gasket packing (Figure 5-25)*, on page 5-37.
9. Install the heat exchanger assembly on the engine. Install and tighten bolts and clamps (**Figure 7-25, (1), (2)**).

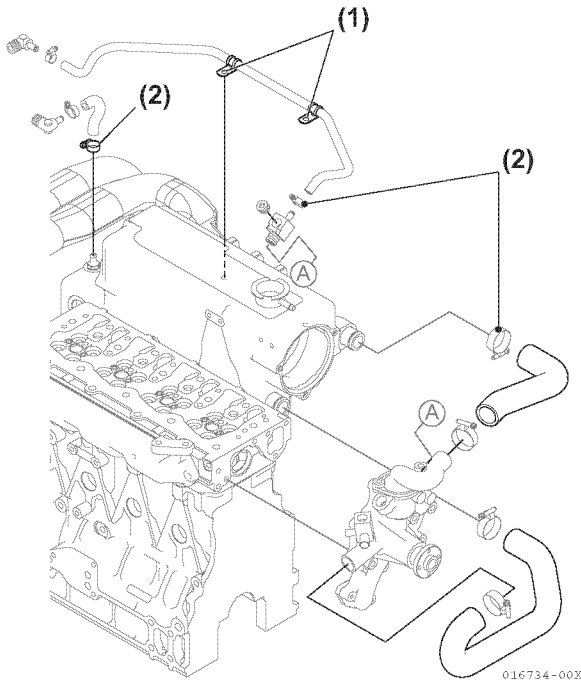

Figure 7-25

10. Connect coolant pipes to heat exchanger.
11. Connect remaining seawater and coolant pipes to heat exchanger.
12. Fill the system with coolant. *Drain and Fill Closed Cooling System* on page 7-13.
13. Start the engine and check for coolant leaks. Check coolant level and fill as necessary.

DISASSEMBLE AND ASSEMBLE HEAT EXCHANGER

1. Remove heat exchanger from engine. See *Remove the heat exchanger and gasket packing (Figure 5-25)*, on page 5-37.
2. Remove outlet cover (**Figure 7-26, (1)**), (**Figure 7-27, (1)**) and gasket (**Figure 7-26, (2)**), (**Figure 7-27, (2)**).

3JH4E Engine

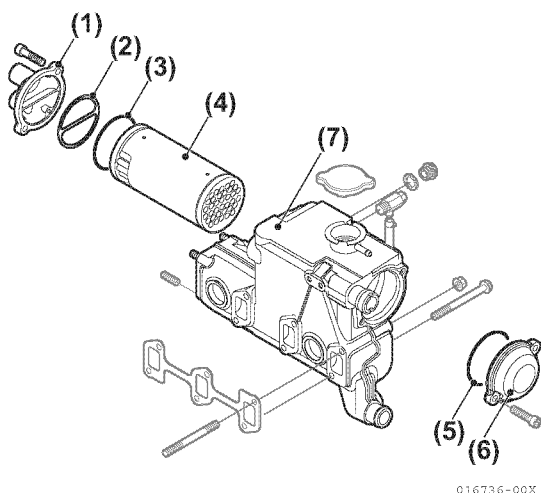

Figure 7-26

4JH4AE/4JH4-TE/4JH4-HTE Engines

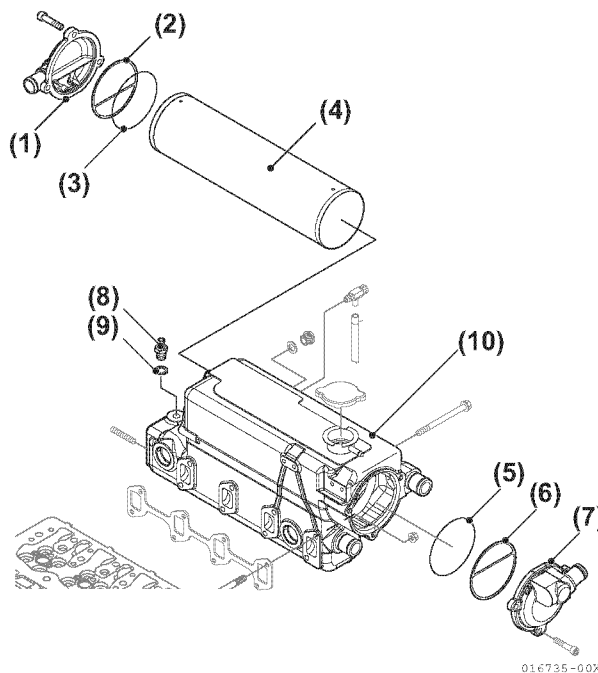

Figure 7-27

3. Remove inlet cover (**Figure 7-26, (6)**) and (**Figure 7-27, (7)**) and gasket (**Figure 7-26, (5)**) and (**Figure 7-27, (6)**).
 4. Pull core from housing (**Figure 7-26, (4)**) and (**Figure 7-27, (4)**).
 5. Remove O-rings (**Figure 7-26, (3), (5)**), (**Figure 7-27, (3), (5)**).
 6. Remove plug (**Figure 7-27, (8)**) and gasket (**Figure 7-27, (7)**). *NOTICE: NEVER use caustic soda be used to clean the components. Use paraffin-based engine detergent to clean the cooler element. Thoroughly flush and rinse all components.*
 7. If any internal deposits remain in the tubes, consult a local radiator repair shop.
- Note: Always install new O-rings.
8. Install new O-ring (**Figure 7-26, (3),(5)**), (**Figure 7-27, (3),(5)**) on cooler core.
 9. Install cooler core, gasket and inlet cover (**Figure 7-26, (6)**), (**Figure 7-27, (6), (7)**).
 10. Install O-ring (**Figure 7-26, (3)**), (**Figure 7-27, (3)**) between core and housing (**Figure 7-26, (5)**), (**Figure 7-27, (5)**).
 11. Install gasket (**Figure 7-26, (2), (6)**) and outlet cover (**Figure 7-26, (1)**), (**Figure 7-27, (1)**).

12. Install new zinc anode (**Figure 7-27, (8)**) and washer (**Figure 7-27, (9)**). See *Drain and Fill Closed Cooling System* on page 7-13.
13. Install heat exchanger, absorber A and B (for 4JH4-TE and 4JH4-HTE only) to cylinder head. See *Remove the heat exchanger and gasket packing (Figure 5-25)*, on page 5-37.

REMOVE AND INSTALL COOLANT PUMP

1. Drain coolant from engine. See *Drain and Fill Closed Cooling System* on page 7-13.
2. Remove belt cover.
3. Remove coolant pump belt and pulley. See *Replace Coolant Pump Belt and Pulley* on page 7-23.
4. Remove thermostat assembly. See *Remove and Install Thermostat* on page 7-21.
5. Remove four bolts (**Figure 7-28, (1)**) and remove coolant pump (**Figure 7-28, (2)**). **NOTICE:** Use caution when removing old gasket to avoid damage to the sealing surface of the cylinder block.

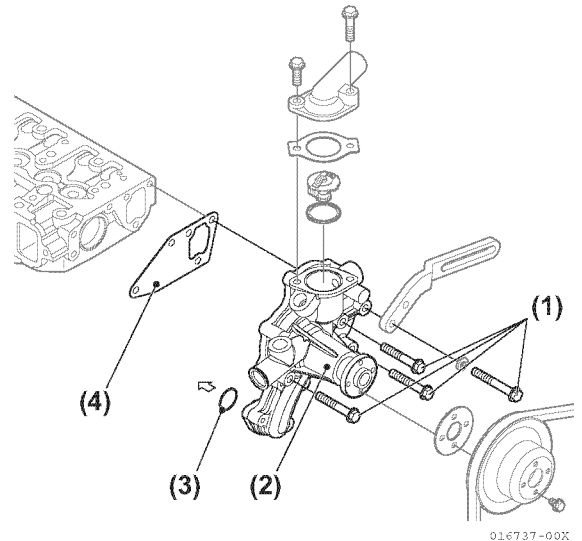

Figure 7-28

6. Remove the old gasket (**Figure 7-28, (4)**) and clean any material off from cylinder head. **NOTICE:** NEVER disassemble coolant pump. It is difficult to disassemble and, once disassembled, even more difficult to reassemble. Replace coolant pump assembly as necessary.
7. Check new gasket (**Figure 7-28, (4)**) and new O-ring (**Figure 7-28, (3)**) fit on cylinder head and cylinder block before proceeding.

8. Hold new gasket in place and install coolant pump.
9. When installing coolant pump assembly to cylinder block, tighten two bolts (M6 x 20) at cylinder block inlet to specified torque (**Figure 7-29, (1)**).

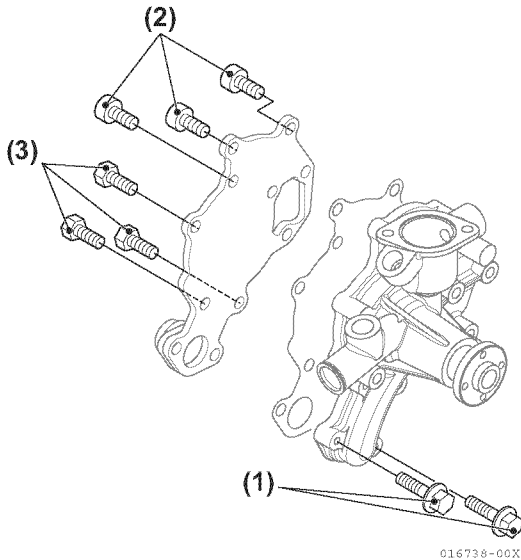

Figure 7-29

Note: When replacing coolant pump and pump cover, tighten M6 bolts to specified torque (**Figure 7-29, (2), (3)**).

Bolt size	Torque
M6 x 20	8.82 - 10.8 N·m (6.5 - 8.0 lb-ft)

Bolt size	Torque
M6 x 15	9.3 - 11.3 N·m (6.9 - 8.3 lb-ft)
M6 x 16	8.82 - 10.8 N·m (6.5 - 8.0 lb-ft)

10. Install thermostat assembly. See *Remove and Install Thermostat* on page 7-21.
11. Fill engine block with coolant. See *Drain and Fill Closed Cooling System* on page 7-13.
12. Start the engine and check for coolant leaks. Check the level of the coolant and fill as necessary.

REMOVE AND INSTALL THERMOSTAT

Removal

1. Allow the engine to cool and drain the coolant from the engine block. *See Drain and Fill Closed Cooling System on page 7-13.*
CAUTION! ALWAYS wear eye protection and rubber gloves when you handle Long Life engine coolant. If the coolant comes in contact with the eyes or skin, flush eyes and wash immediately with clean water.
2. Release clamps on coolant lines (Figure 7-30, (1)).

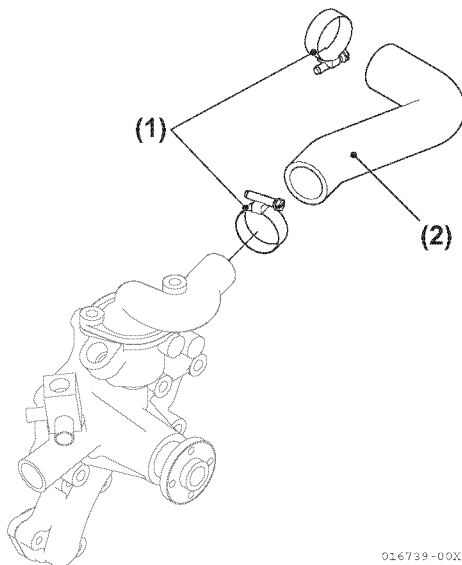

Figure 7-30

3. Disconnect pipe (Figure 7-30, (2)) from coolant pump.
4. Remove two bolts (Figure 7-31, (4)).

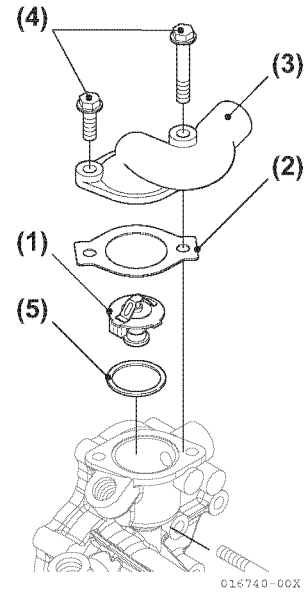

Figure 7-31

5. Remove cover and gasket (Figure 7-31, (3),(2)).
6. Remove the thermostat (Figure 7-31, (1)).
7. Test thermostat as required. *See Test Thermostat on page 7-9.*

Installation

1. Clean the thermostat housing.
2. Change new gaskets (Figure 7-31, (2),(5)) install on coolant pump housing.
3. Install thermostat assembly.
4. Install cover and gasket and tighten bolts.
5. Install coolant pipe and secure with clamps.
6. Fill the system with coolant. *See Drain and Fill Closed Cooling System on page 7-13.*
7. Start the engine and check for coolant leaks. Check the level of the coolant and add as necessary.

SEAWATER PUMP

Inspect / Replace Impeller

The seawater pump is driven by the gear (Figure 7-32 (3)), (Figure 7-33 (1)).

3JH4E and 4JH4AE Engines

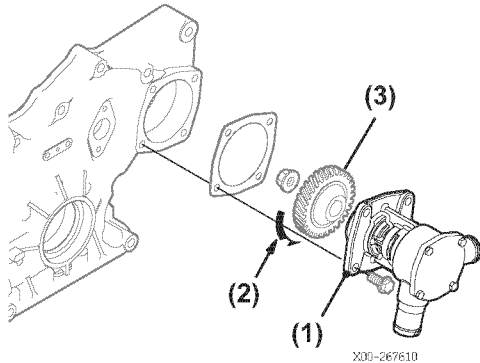

Figure 7-32

4JH4-TE and 4JH4-HTE Engines

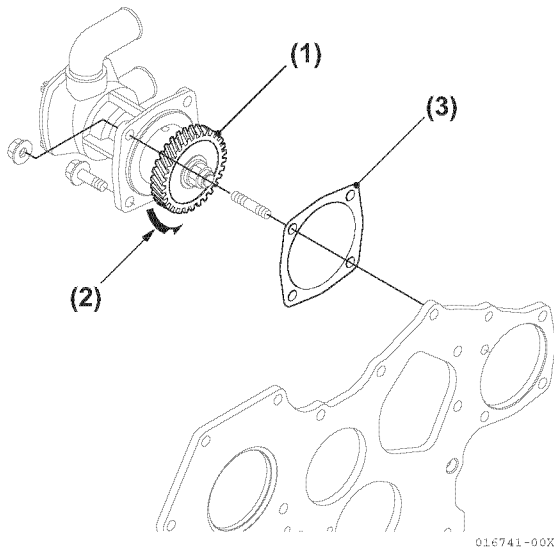

Figure 7-33

1. Drain the seawater by loosening the bolts of seawater pump side cover (Figure 7-32, (1)).
2. Disconnect seawater hoses from seawater pump inlet and outlet, then remove seawater pump assembly from gear case.

3. Remove seawater pump drive gear (Figure 7-33, (1)).
4. Remove four bolts, side cover (Figure 7-34, (1)) and O-ring (Figure 7-34, (2)).

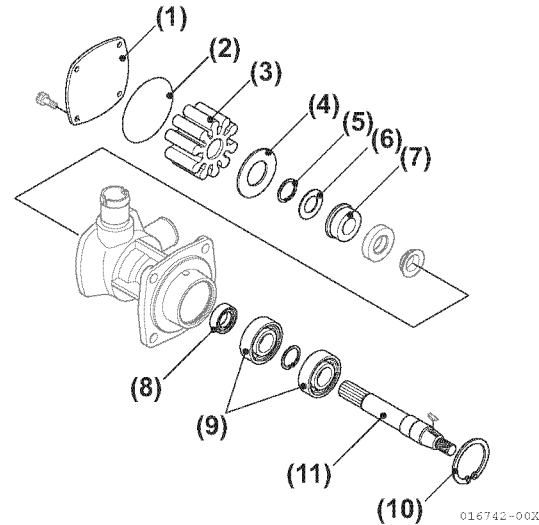

Figure 7-34

5. Remove the impeller (Figure 7-34, (3)) and wear plate (Figure 7-34, (4)) from the housing.
 6. Remove retainer, washer and mechanical seal (Figure 7-34, (5), (6), (7)).
 7. Using pliers from drive gear side, remove retainer (Figure 7-34, (10)) which holds bearings (Figure 7-34, (9)).
 8. Lightly tap pump shaft from impeller side and remove shaft and bearings as a set (Figure 7-34, (11), (9)).
 9. Remove lip seal (Figure 7-34, (8)) and mechanical seal if necessary.
 10. Inspect the impeller for cracks, broken vanes or excessive wear. Replace as necessary.
- Note: When installing the new impeller, rotate the impeller clockwise to bend the vanes in the direction of rotation (Figure 7-34, (3)).
11. Inspect wear plate and replace as necessary.
 12. Inspect the housing and cover for excessive wear.

- Inspect mechanical seal and replace if spring is damaged or seal is corroded.

Note: Replace mechanical seal if there is considerable coolant leakage during operation.

Coolant leakage	less than 3cm ³ /hour (0.101 ounce/hour)
-----------------	--

- Make sure ball bearings rotate smoothly. Replace if there is excessive play.
- Install a new O-ring (**Figure 7-34, (2)**) and hold it in the groove using petroleum jelly.
- Install the shaft assembly, gear and side cover. Install and tighten four bolts.
- Install the seawater pump assembly with new gasket (**Figure 7-35, (5)**) to gear case.

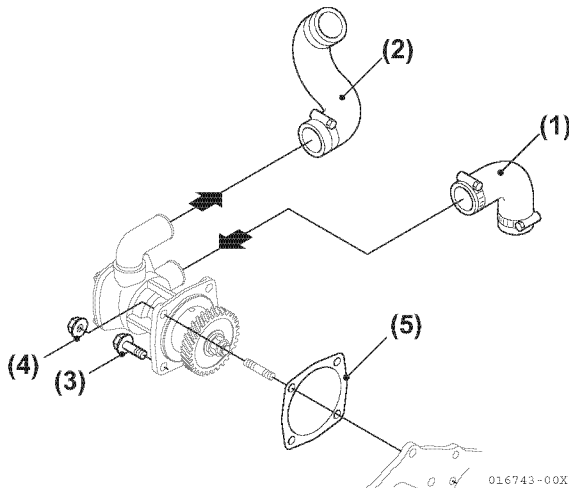

Figure 7-35

Remove and Install Seawater Pump and Pump Drive Gear

- Disconnect negative (-) battery cable.
- Disconnect seawater supply hose from seawater pump (**Figure 7-35, (1)**).
- Disconnect seawater pump-to-heat exchanger pipe (**Figure 7-35, (2)**).
- Remove three bolts (**Figure 7-35, (3)**) and one nut (**Figure 7-35, (4)**) then remove seawater pump.
- Repair as necessary.
- Install the seawater pump in the reverse order of removal.

Note: When installing, use the new gasket (**Figure 7-35, (5)**).

- Connect battery negative (-) cable.

Replace Coolant Pump Belt and Pulley

- Disconnect negative (-) battery cable.
- Remove belt cover (**Figure 7-36, (1)**).

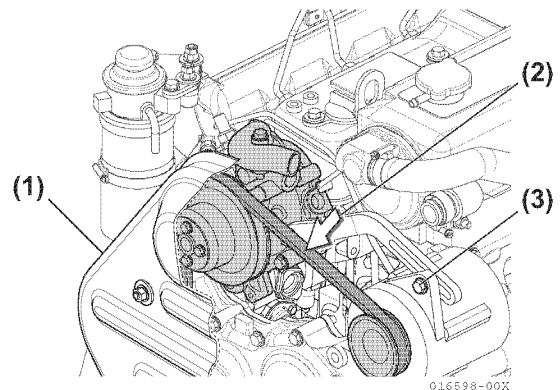

Figure 7-36

3. Check belt tension by pressing on the belt (**Figure 7-37, (A)**). Allowable belt deflection is shown below. If the belt is loose, it must be replaced.

Belt Category	Belt Deflection (A)
Used Belt	8 - 10 mm (0.3 - 0.4 in.)
New Belt	6 - 8 mm (0.24 - 0.3 in.)

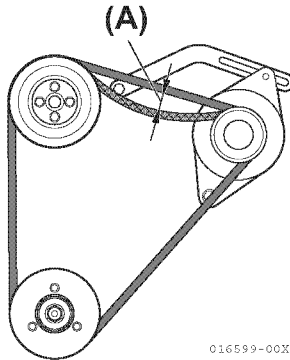

Figure 7-37

4. Loosen adjusting bolt (**Figure 7-36, (3)**) to remove coolant pump belt.

5. Check grooves of pulleys and tightening bolts. Replace pulley or bolts as necessary (**Figure 7-38**).

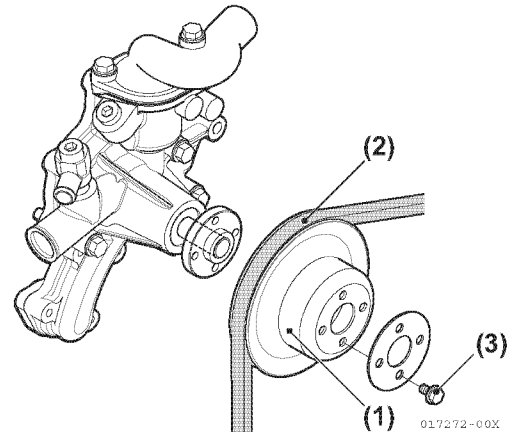

Figure 7-38

- 1 – Pulley
- 2 – V-Belt
- 3 – Bolt

6. Install new belt on crankshaft, alternator pulley and around coolant pump pulley. **CAUTION!** Use caution to avoid pinching fingers between belt and pulley while installing belt. **NOTICE:** Ensure belt is correctly engaged in all grooves of both pulleys.
7. Install belt cover.
8. Connect negative (-) battery cable. Start engine and verify pump operation.

COOLANT RECOVERY TANK

Function of the Coolant Recovery Tank

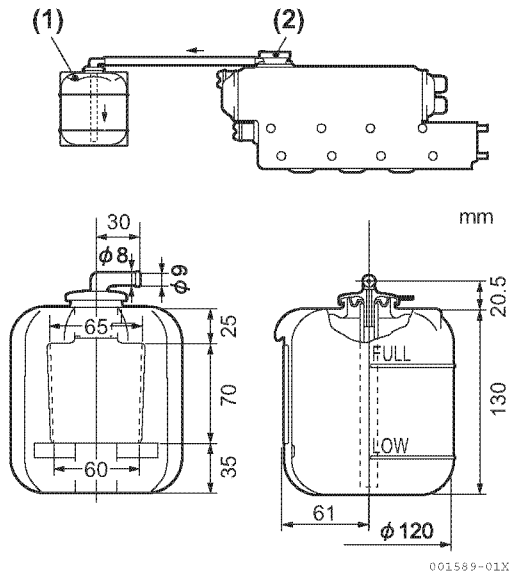

Figure 7-39

- 1 – Coolant Recovery Tank**
2 – Filler Cap

The pressure valve opens to discharge steam when the steam pressure in the freshwater tank exceeds 82-109 kPa, 0.84-1.11 kgf/cm² (12-16 psi).

This consumes water. The coolant recovery tank maintains the water level by preventing this discharge of water.

The steam discharged into the coolant recovery tank condenses into water, and the water level in the tank rises.

When the pressure in the freshwater system drops below the normal value, the water in the coolant recovery tank is sucked back into the freshwater tank to raise the water back to its original level.

The coolant recovery tank enables long hours of operation without water replacement and eliminates the possibility of burns when the steam is ejected from the filler neck because the pressure cap does not need to be removed.

Specification of Coolant Recovery Tank

Capacity Of Coolant Recovery Tank	Overall Capacity	1.3 L (1.37 qt)
	Full-scale Level	0.8 L (0.85 qt)
	Low Scale Level	0.2 L (0.21 qt)

Mounting the Coolant Recovery Tank

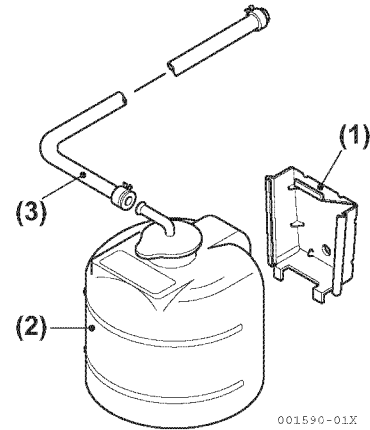

Figure 7-40

- 1 – Mounting Plate**
2 – Subtank
3 – Overflow Tube

- The coolant recovery tank is mounted at approximately the same height as the heat exchanger (freshwater tank). Allowable difference in height: 300 mm (11.8 in.) or less.
- The overflow pipe should be less than 1000 mm (39.4 in) long, and mounted so that it does not sag or bend.

Note: Make sure that the overflow pipe of the coolant recovery tank is not submerged in bilge. If the overflow pipe is submerged in bilge, water in the bilge will be siphoned into the freshwater tank when the wafer is being cooled.

Before Use of Coolant Recovery Tank

Check the coolant recovery tank when the engine is cool and refill with freshwater as necessary to bring the water level between the low and full marks. Check the overflow pipe and replace if bent or cracked. Clean out the pipe if it is clogged.

BILGE PUMP AND BILGE STRAINER (OPTIONAL)

Specification

Name	BILGE PUMP
Time	10 minutes
Rotation Direction	Right (Viewed from the impeller side)
Mass Weight	Pump 1.4 kg (3 lb)
Negative (-) Pressure Detector	Diaphragm type
Temperature	-30 - 80°C (86 - 176°F)
Length	225 mm (8.8 in.)
Yoke Diameter	61 mm (2.4 in.)
Assembly Hole Diameter	5.3 mm (0.208 in.)
Assembly Pitch	50 x 90 mm (2 x 3.5 in.)

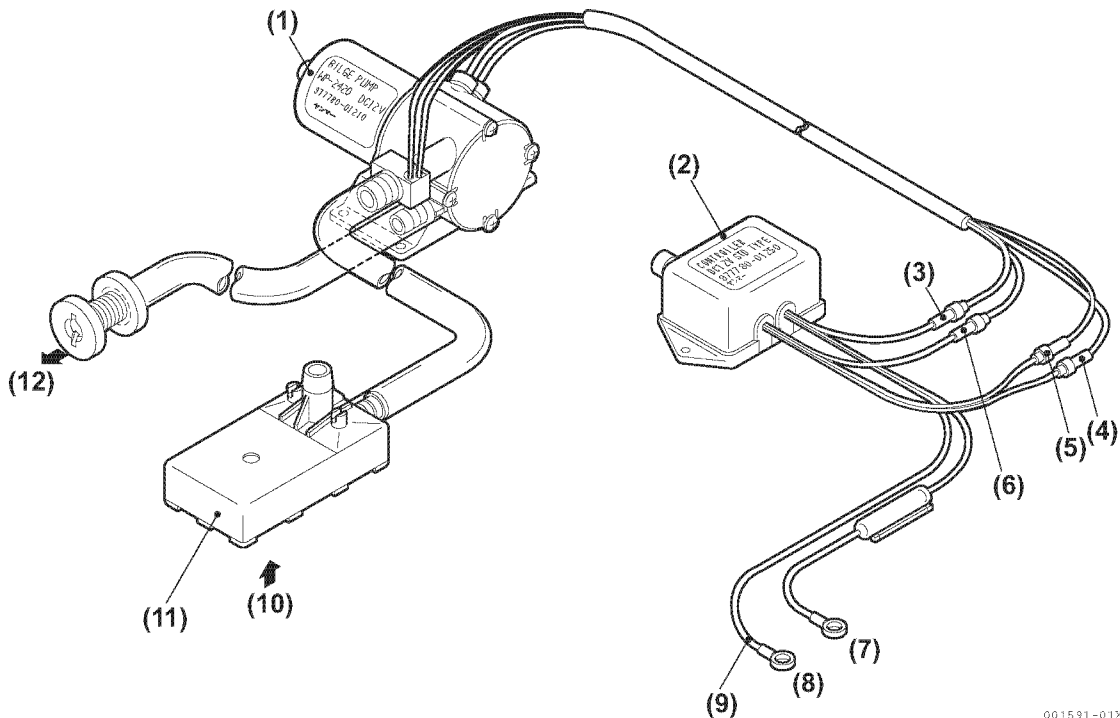

001591-01X

Figure 7-41

- 1 – Motor Assy
- 2 – Controller
- 3 – White
- 4 – Green
- 5 – Blue
- 6 – Red

- 7 – Red (+)
- 8 – Battery
- 9 – White (-)
- 10 – Inlet
- 11 – Strainer
- 12 – Outlet

Description**Characteristics**

- Discharge at lift: 0 m(0 ft) discharge capacity: 20 L (5.2 gal) minimum or greater.
- Automatic feeding height: 1 m (3.2 ft) or greater [Limit for automatic feeding height: new pump with inside parts wet, approximately 2 m(6.6 ft)]
- Automatic feeding time: 2-5 seconds. (Limit for automatic feeding time: new pump with inside parts wet, approximately 1 second.)
- Automatic stopping: Air intake causes negative (-) pressure triggering automatic stopping.

Insulation

- Insulation resistance: 500V with a megatester when the difference between the continuity point and the body is 1MΩ or greater.
- Insulation proof stress: AC50 between the continuity point and the body, or 60hz 500V for 1 min. when impressed current leakage is 10 mA or lower.

Durability

Rated voltage when there is 3% salt water 60L + engine oil 3%, and operation is at 1800 cycles and there are no difficulties.

Vibration proof

Amplitude 0.51 mm (0.02 in.)

Vibration frequency 10-55 Hz

Sweep time 90 seconds.

Direction of vibration each direction 4 hours

No difficulties after test period

Cautions

- Attach at a position higher than the bilge water away from rain or other water, and 50-70 cm (19.7 - 27.6 in.) above the bottom of the boat.
- Never run the pump dry. Be sure that the strainer is inserted in the drain water before pushing the switch. If no water is being drawn up after a period of 10 seconds or more, prime the pump. (Do not run the pump for longer than 10 seconds when no water is being drawn up.)

- When the pump has not been used for a long period of time, the inside of the pump will be dry and drawing ability will be lowered. Before reusing, clean the inside of the pump or prime it to ensure that it is wet, and check to be sure that the pump operates correctly.
- When charging the diesel engine oil, wait a period of 30 minutes or longer from the time of stopping oil temperature 20-70°C (68 - 158°F). Refrain from operation when the oil temperature is below 15°C (59°F), or above 50°C (122°F).
- When the bilge inside the pump or hose freezes, completely melt the water with a steaming towel before beginning operation. When the temperature inside the pump is low, it will take a longer amount of time for the pump to drain off the bilge.
- The impeller replacement kit includes one impeller and three washers for adjusting the side gap. If after replacing the impeller the pump does not drain, place side gap adjustment washers underneath the bottom plate to adjust. Select the number of washers used in accordance with the following. When the pump is draining, the electric current load is about 5A. When there are too many washers, the electric current value will be too great and will blow a fuse.
- The pump cannot be used to drain off rain water or large amounts of flood water. The pump can be run continuously for a period of 10 minutes. After this time it must shut off for a period of 2 hours before reusing.
- NEVER use the pump for showering. If the pump outlet is deformed for showering, the increase in water pressure will increase the load on the motor and cause motor seizure.
- Fix the strainer so that it will not turn upside down or on its side.
- When sludge has built up in the bilge to be drained, position the strainer about 20 mm (0.79 in.) above the sludge. When the pump is stopped, be sure there is no sludge remaining inside the pump.
- The specific gravity of the battery fluid is 1.25 or more.

Assembly

When bilge is being used, assemble in accordance with the following.

1. Assembling the bilge pump:
 - Select a dry place above the bilge water level.
 - Select the location for the bilge pump taking into consideration the length of the switch cable (approximately 3 m [9.8 ft]) and its attachment point, and the position of the battery.
 - Position at a 45° angle (**Figure 7-42**) with the nozzle facing up, and 50-70 cm (19.7-27.6 in.) from the bottom of the boat.

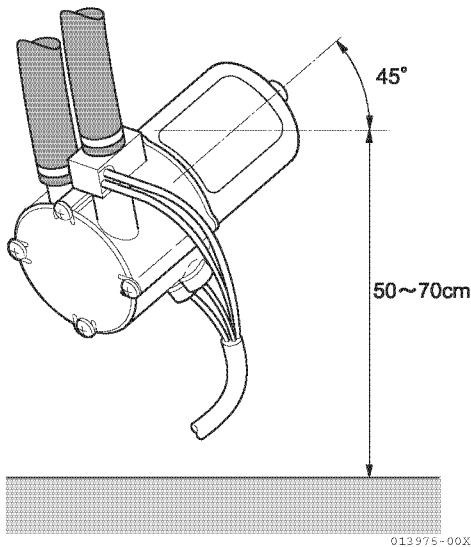

Figure 7-42

2. Assembling the switch:

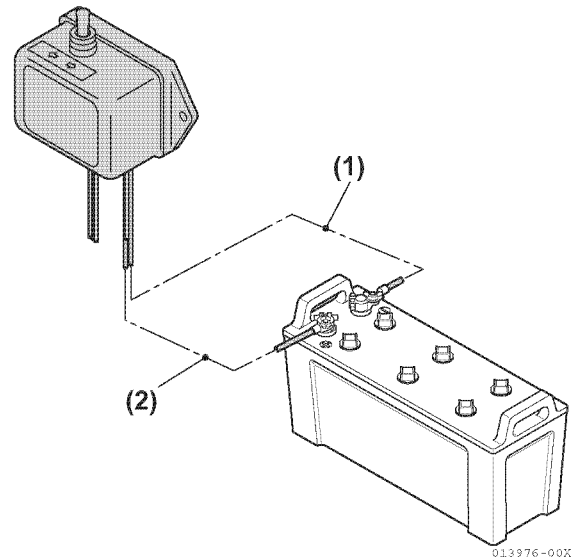

Figure 7-43

- 1 – Red wire (+)
- 2 – White wire (-)

- Attach in a place to ensure easy operation away from rainwater.
- Connect the terminal to the battery. When the cord will not reach the battery, an extension of no greater than 3 m(9.8 ft) length suitable for AV3mm² can be attached.
- Position the strainer. Attach at the place where the greatest amount of water is collected when the boat is stopped.

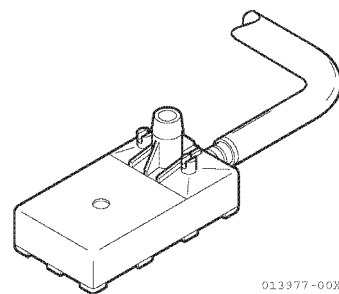

Figure 7-44

- It is best to place the strainer as close to the bilge pump as possible. Cut the 3 m (9.8 ft) hose to a length of 1.2 m-1.8 m (3.9-5.9 ft) and attach allowing plenty of give.
- Check the strainer during a test operation before screwing firmly into place. **CAUTION! When attaching the strainer, avoid damaging the bottom of the boat.**

Note: The strainer contains a weight, and can be used with the weight in place.

- Always keep the strainer clean.

3. Attaching the delivery nozzle (outlet):

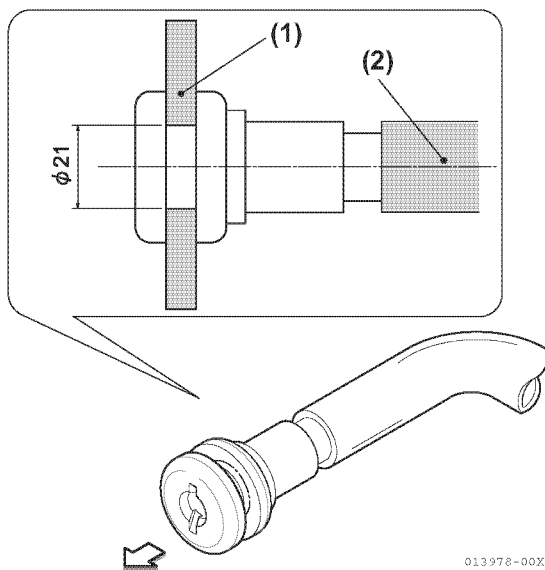

Figure 7-45

- 1 – Hull side
- 2 – Hose

- Make a hole of 21 mm (0.8 in.) diameter or less for attaching the nozzle. The hose attached at the nozzle should be 1.8 m (5.9 ft) or less and should reach without any strain, therefore care should be taken in deciding on the best position.
- Fix the outlet nozzle in place and attach to the discharge side of the pump.

4. Attaching the hose:

- Attach the hose from the strainer to the pump inlet.
- Attach the delivery nozzle hose to the pump outlet.
- Make the hose as short as possible and avoid sharp bends.

5. Test operation:

- Collect water in the bottom of the boat and check for any problems with the hose or wiring. After doing this, connect the battery.
- Turn on the pump switch, and check to see that water is being taken in and discharged properly. The pump will stop automatically when there is no water left.
- If the inside of the pump is dry, or if the water is not being drawn up after a period of 10 seconds, lift the strainer above the water surface and stop the pump. Prime the pump before starting it up again.

6. Fixing the strainer:

- After the test operation, fix the strainer into place with bolts. **CAUTION! When attaching the strainer, avoid damaging the bottom of the boat.**

Cautions During Assembly

Observe the following cautions during handling.

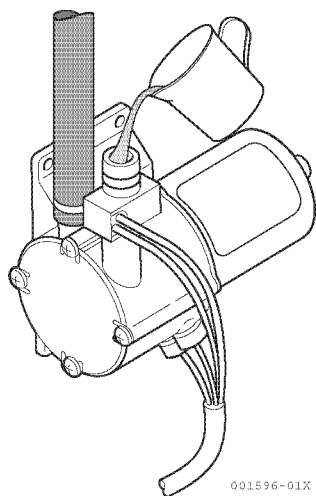

Figure 7-46

- NEVER use gasoline or solvents.
 - 1) gasoline 2) ester 3) benzol 4) battery fluid 5) liquids at 70°C (158°F) or greater or lubricating oil
- NEVER run when there is no water in the bilge. Check to be sure that the strainer is in the water before turning on the switch.
- Keep the cord terminal away from the water. Water inside the motor or switch may lead to damage. When the insulation around the cord is damaged, water can seep in to the wires; thus, care should be taken not to scratch or nick the insulation.
- When the pump has not been used for a long period of time, the inside of the pump will be dry and it may not operate properly at first. If after 10 seconds the pump is not working, turn off the switch and prime the pump before trying again. *NOTICE: Never run the pump dry for period of greater than 10 seconds.*
- Replace the lubricating oil only after the engine has been stopped for a period of 30 minutes (oil temperature 20-70°C [60-158°F]). Whenever possible refrain from operation when the oil temperature is below 15°C (59°F) or above 50°C (122°F).

- Bilge water left in the hose or inside the pump can freeze, and care should be taken to see that any excess bilge is completely discharged. If bilge water should freeze, and care should be taken to see that any excess bilge is completely discharged. If bilge water should freeze inside the hose or pump, it should be completely melted before starting up the pump. When the temperature inside the pump is low, the pump will take longer to operate. (0°C [32°F], 5-10 seconds.)
- Keep the pump in a dry place away from rain or other water.
- Use the regulation hose; do no use thin vinyl hose or hose which is not heat-resistant.
- The pump cannot be used to drain off rainwater or large quantities of flood water. This pump can be operated continuously for a period of 10 minutes.
- NEVER use the pump for showering. If the pump outlet is deformed for showering, the increase in water pressure will increase the load on the motor and cause motor seizure.
- When sludge has built up in the bilge to be drained, position the strainer about 20 cm (7.9 in.) above the sludge. When the pump is stopped, be sure there is sludge remaining inside the pump housing.
- The specific gravity for the battery fluid is 1.25.

Steps for replacement

1. Remove the impeller plate by taking out the M4 bolts and opening the top of the diaphragm switch. Thread locking compound has been applied to the bolt, and a dryer should be used to heat the bolt before removing it.
2. Clean the inside of the pump.
3. Grease the plate, impeller and film for side gap adjustment, and then reassemble the pump by first inserting the film plate and then the impeller.

Troubleshooting

Refer to the following countermeasures for difficulties that arise.

No.	Problem	Cause	Countermeasure
1	Pump does not turn	Faulty wiring	Check the wiring between the motor and battery.
		Faulty battery	Check to see if the specific gravity of the battery fluid is greater than 1.25. Recharge or replace the battery.
		Faulty starter switch	Consult your local dealer.
		Faulty pump	Consult your local dealer.
2	Pump turns but does not draw up water.	Draws up air.	Check hose connections. Retighten pump bolts.
		Low voltage in battery.	Check to see if the specific gravity of the battery fluid is greater than 1.25. Recharge or replace the battery.
		The distance between the pump and the surface of the water is too great.	Lower the pump. (Position the pump so that it is closer to the surface of the water.)
		The pump is too high.	Lower the pump. (Position the pump so that it is 50-70 cm above the bottom of the boat.)
		Pump intake is weak.	If intake is still faulty after priming, consult your local dealer.
3	Pump turns, but the amount of discharge is low.	Clogged strainer	Clean strainer.
		Hose is broken or damaged.	Check for damage and repair. If incorrect hose has been used, replace with the regulation type of hose.
4	Water leakage from pump	Water leakage from packing	Retighten pump bolts.
		Faulty pump seal	Consult your local dealer.
5	Pump draws up bilge, but motor stops when hand is removed from starter switch.	Faulty diaphragm switch	Check for loose wiring in diaphragm switch and correct.
		Damaged diaphragm switch	Consult your local dealer.
6	Motor does not stop, when there is no bilge water left	Clogged strainer or hose	Clean strainer or hose.
		Damaged diaphragm switch	Check for continuity of diaphragm switch terminal. Consult your local dealer if there is continuity.

This Page Is Intentionally Left Blank

Section 8

LUBRICATION

	Page
Safety Precautions	8-3
Introduction.....	8-3
Specifications	8-4
Test and Adjustment Specifications	8-4
Special Torque Chart.....	8-4
Special Service Tools.....	8-4
Measuring Instruments	8-4
Tests and Adjustments.....	8-5
Engine Oil Flow	8-5
Check Engine Oil Pressure	8-6
Repair.....	8-7
Engine Lubrication System Components	8-7
Change Engine Oil, Replace Engine Oil Filter Element and Clean Engine Oil Cooler	8-9
Remove and Install Engine Oil Sump.....	8-11
Engine Oil Pump.....	8-11
Piston Cooling Oil Nozzle Check.....	8-14

This Page Intentionally Left Blank

SAFETY PRECAUTIONS

Before you service the lubrication system, read the following safety information and review the *Safety Section on 2-1*.

NOTICE

Indicates a situation which can cause damage to the machine, personal property and / or the environment or cause the equipment to operate improperly.

Only use the engine oil specified. Other engine oils may affect warranty coverage, cause internal engine components to seize and / or shorten engine life. NEVER mix different types of engine oil. This may adversely affect the lubricating properties of the engine oil.



ALWAYS be environmentally responsible.

Follow the guidelines of the EPA or other governmental agencies for the proper disposal of hazardous materials such as engine oil, diesel fuel and engine coolant. Consult the local authorities or reclamation facility.

NEVER dispose of hazardous materials by dumping them into a sewer, on the ground or into ground water or waterways.

INTRODUCTION

This section of the *Service Manual* describes the procedures necessary to service the 3JH4E, 4JH4AE, 4JH4-TE and 4JH4-HTE lubrication systems.

SPECIFICATIONS

Test and Adjustment Specifications

Note: All pressure specifications are with engine at normal operating temperature.

Inspection Item	Model	Test RPM	Specification
Oil Pressure	3JH4E and 4JH4AE	800	0.06 MPa (8.7 psi) or more
		3000	0.39 - 0.54 MP (57 - 78 psi)
	4JH4-TE and 4JH4-HTE	800	0.06 MPa (8.7 psi) or more
		3200	0.28 - 0.45 MPa (41 - 65 psi)

Special Torque Chart

Component	Tightening Torque	Lubricating Oil Application	Reference Page
Lubricating oil inlet pipe	26 N·m (lb-ft)	Not Applied	See <i>Install Engine Oil Pump</i> on page 8-14

SPECIAL SERVICE TOOLS

Measuring Instruments

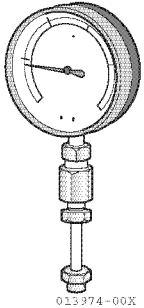
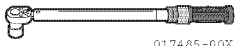
No.	Tool Name	Application	Illustration
1	Oil Pressure Test Gauge	For measuring oil pressure 0 - 10MPa (0 - 145.04 psi) obtained local	 013974-00X
2	Torque Wrench	For tightening nuts and bolts to the specified torque 0 - 128 N·m (0 - 94.4 lb-ft) obtained local	 017485-00X

TESTS AND ADJUSTMENTS

Engine Oil Flow

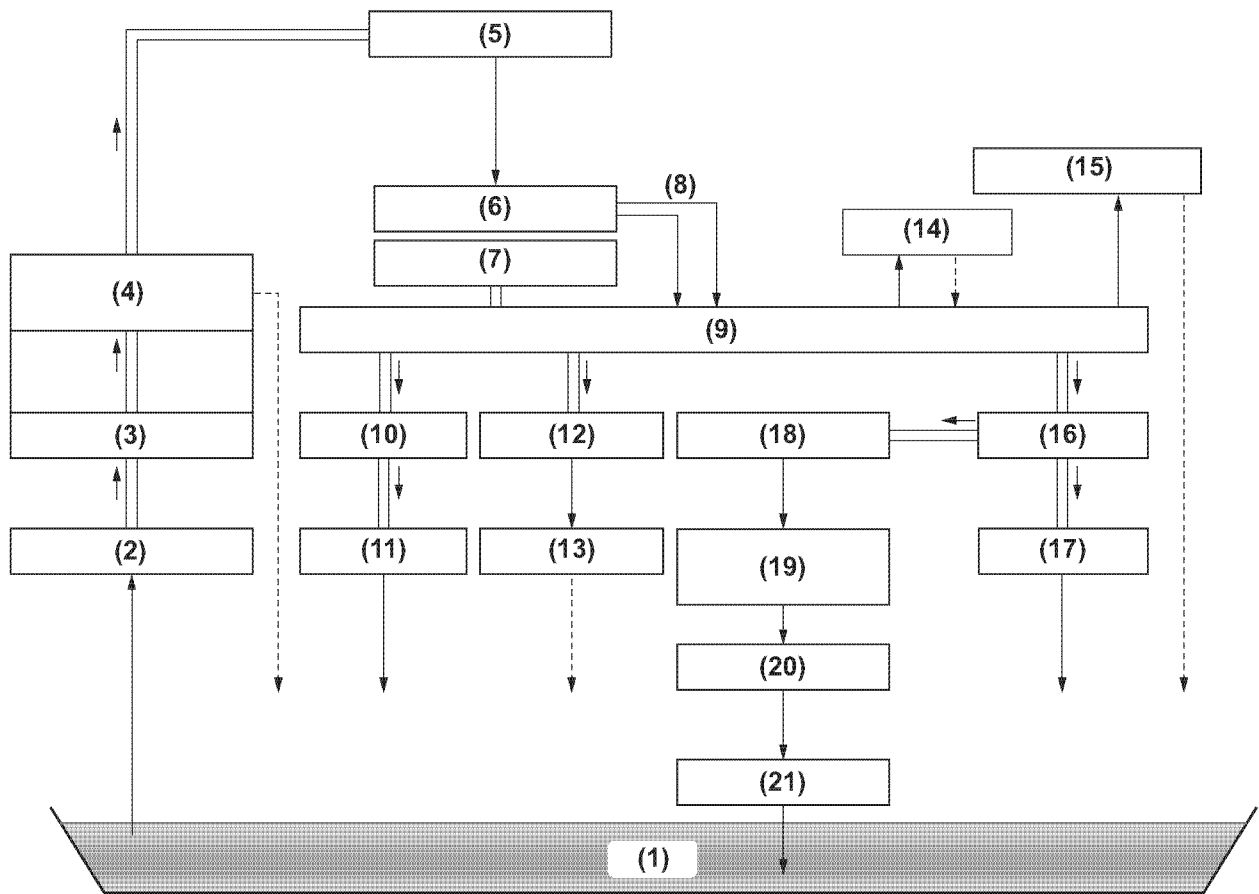

016692-00X

Figure 8-1

- | | |
|--|-----------------------------|
| 1 – Oil Sump | 12 – Cooling Oil Nozzle |
| 2 – Oil Filter (Water / Oil Separator) | 13 – Piston |
| 3 – Oil Pump | 14 – Turbocharger |
| 4 – Oil Pressure Regulating Valve | 15 – Fuel Injection Pump |
| 5 – Oil Cooler | 16 – Crank Journal |
| 6 – Oil Filter | 17 – Crank Pin |
| 7 – Oil Pressure Switch | 18 – Camshaft Bearing |
| 8 – Oil Return | 19 – Valve Rocker Arm Shaft |
| 9 – Cylinder Block Main Gallery | 20 – Valve Rocker Arm |
| 10 – Idle Gear Shaft | 21 – Tappet and Cam Face |
| 11 – Idle Gear Face | |

Check Engine Oil Pressure

Perform an engine oil pressure check if there is any indication of low oil pressure.

1. Start the engine and allow it to warm to normal operating temperature.
2. Read the pressure gauge at the listed engine speeds.

Results:

3. If oil pressure is still indicated as low, check oil pressure switch or oil pressure gauge.
4. Disconnect oil pressure switch connector. Keep voltmeter probes in contact with switch terminal and cylinder block while operating engine. Replace oil pressure switch (**Figure 8-2, (1)**) if circuit is indicated closed.

Inspection Item	Test RPM	Specification
Engine Oil Pressure	3JH4E 4JH4AE	Idle 0.06 MPa or more (8.7 psi or more)
		3000rpm 0.39-0.54 MPa (56.6-78.3 psi)
	4JH4-TE 4JH4-HTE	Idle 0.06 MPa or more (8.7 psi or more)
		3200rpm 0.28-0.45 MPa (40.6-65.3 psi)

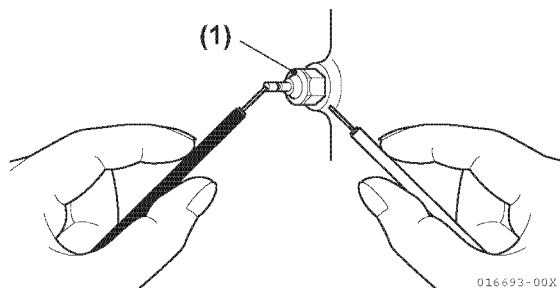
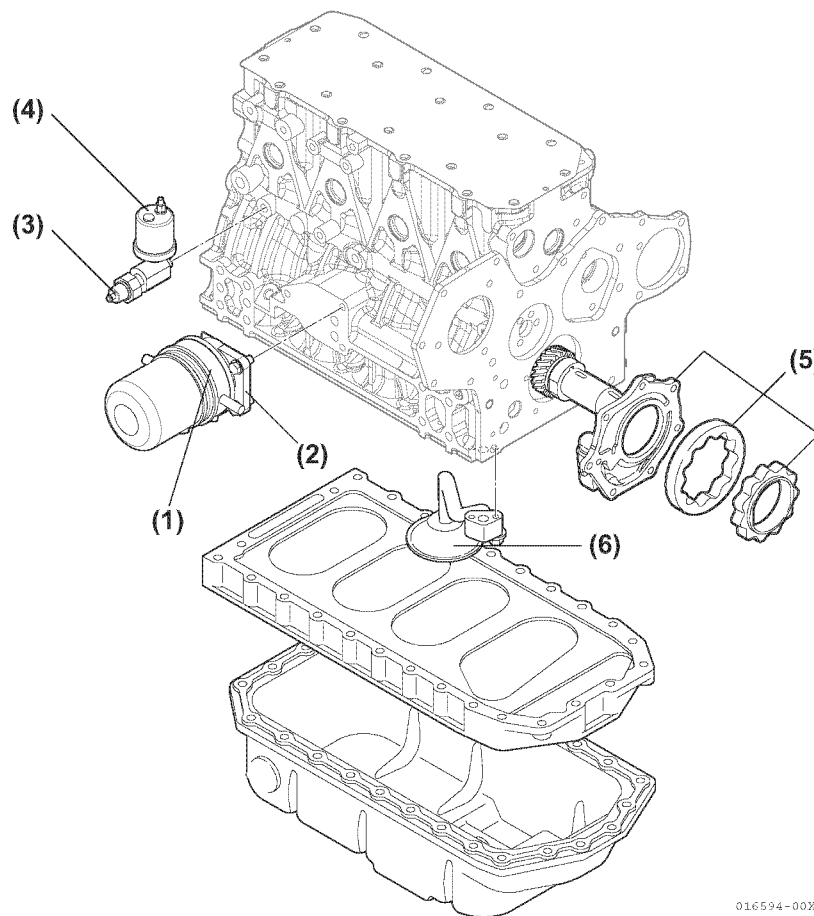

Figure 8-2

5. If oil pressure is still indicated as low, troubleshoot lubrication system to locate the cause of the low oil pressure. Repair as necessary.

REPAIR**Engine Lubrication System Components****4JH4AE Engine shown - 3JH4E engine is similar****Figure 8-3**

- 1 – Engine Oil Cooler**
- 2 – Oil Filter Housing**
- 3 – Oil Pressure Sensor**

- 4 – Oil Pressure Sensor Line**
- 5 – Oil Pump Assembly**
- 6 – Oil Pickup and Screen**

4JH4-TE and 4JH4-HTE Engines

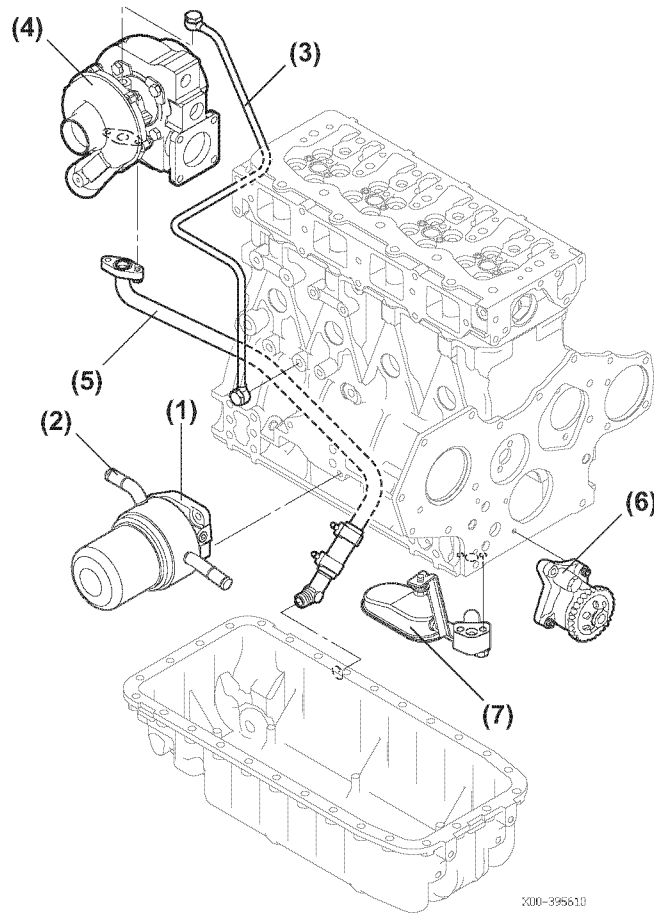

X00-395610

Figure 8-4

- 1 – Engine Oil Cooler
- 2 – Oil Filter Housing Sensor Line
- 3 – Turbocharger Lubrication Supply Line
- 4 – Turbocharger

- 5 – Turbocharger Lubrication Return Line
- 6 – Oil Pump
- 7 – Oil Pickup and Screen

Change Engine Oil, Replace Engine Oil Filter Element and Clean Engine Oil Cooler

The engine oil on a new engine becomes contaminated from the initial break-in of internal parts. It is very important that the initial oil replacement is performed as scheduled.

Drain the lubricating oil while the engine is still warm. **WARNING! If you must drain the engine oil while it is still hot, stay clear of the hot engine oil to avoid being burned. ALWAYS wear eye protection.**

1. Remove oil filler cap (yellow) at top of rocker arm cover (**Figure 8-5, (1)**).

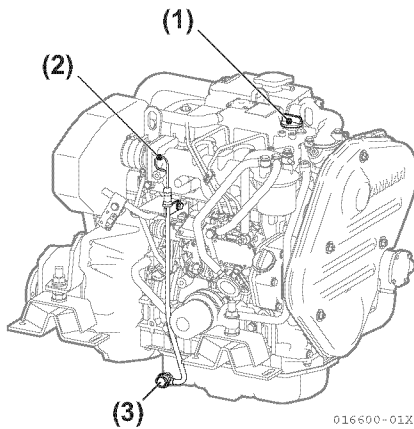

Figure 8-5

2. Remove the engine oil dipstick (**Figure 8-5, (2)**).
3. Attach an oil drain pump to dipstick guide and pump out the oil. Dispose of used oil properly.
4. Remove pipe joint bolt (**Figure 8-5, (3)**) or drain plug (**Figure 8-6, (1)**) and drain engine oil to appropriate vessel. Dispose of used oil properly. **NOTICE: ALWAYS be environmentally responsible.**

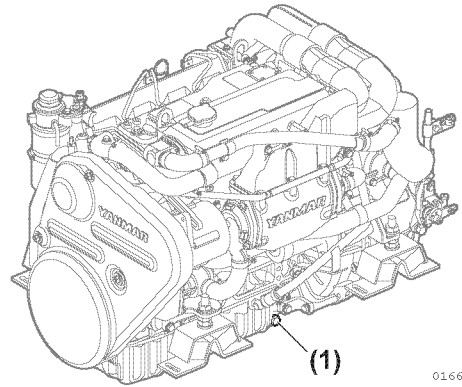

Figure 8-6

5. Tighten pipe joint bolt or drain plug.
6. Drain seawater. *See Drain and Refill Seawater Cooling System on page 7-10.*
7. Remove coolant pipes (cylinder block, engine oil cooler (**Figure 8-7, (1)**), engine oil cooler outlet (**Figure 8-7, (2)**).

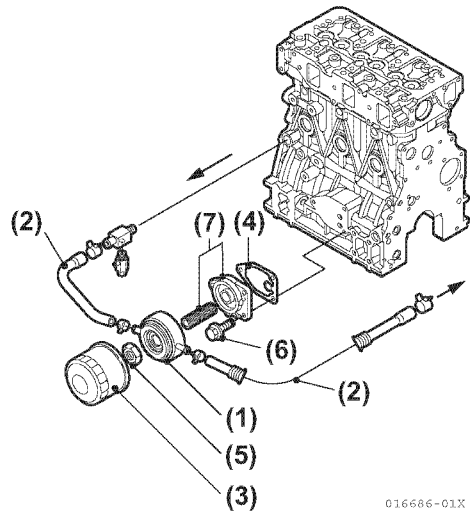

Figure 8-7

8. Turn lubricating oil filter (**Figure 8-7, (3)**) counterclockwise using a filter wrench (**Figure 8-8, (2)**) to remove from lubricating oil cooler (**Figure 8-7, (4)**).

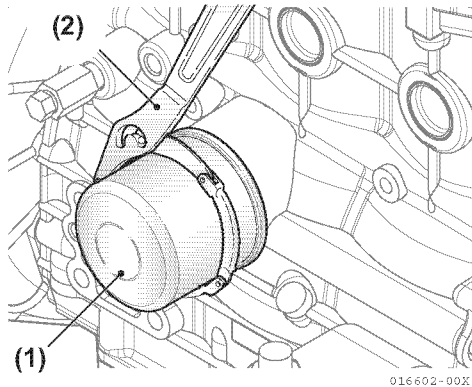

Figure 8-8

9. Remove lubricating oil cooler nut (**Figure 8-7, (5)**) and lubricating oil cooler. Loosen bolts (**Figure 8-7, (6)**) for filter bracket and remove filter bracket (**Figure 8-7, (7)**).
10. Clean or replace lubricating oil cooler and bracket as necessary.
11. Thoroughly clean all sealing surfaces.
12. Install a new filter bracket gasket, bracket and lubricating oil cooler. Secure to cylinder block with bolt.
13. Reassemble coolant pipes to lubricating oil cooler.

14. Coat the new lubricating oil filter seal with lubricating oil and install the lubricating oil filter (**Figure 8-8, (1)**) manually turning it clockwise until the seal touches the mounting surface, and tighten it further to 3/4 of a turn using a filter wrench (**Figure 8-8, (2)**).
15. Tighten to 20 - 24 N·m (177-212 lb-in).
16. Fill with new lubricating oil. *See Engine Coolant Specifications on page 3-44.*
17. Fill the engine with coolant. *See Engine Coolant Specifications on page 3-44.*
18. Perform an engine trial run and check for oil or water leaks.
19. Approximately 10 minutes after stopping engine, remove oil dipstick and check oil level (**Figure 8-9, (1)**). Add oil if level is too low.

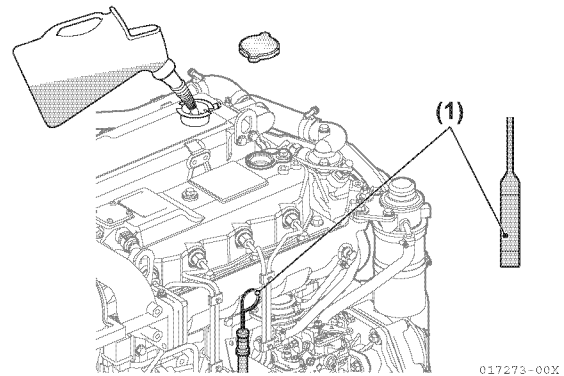

Figure 8-9

Remove and Install Engine Oil Sump

1. Drain engine oil. *See Change Engine Oil, Replace Engine Oil Filter Element and Clean Engine Oil Cooler on page 8-9.*
2. Remove bolt **(Figure 8-10, (2),(3))** securing oil dipstick tube to cylinder block or support. Remove piping bolt **(Figure 8-10, (4))** and oil dipstick tube **(Figure 8-10, (1))** from oil sump.

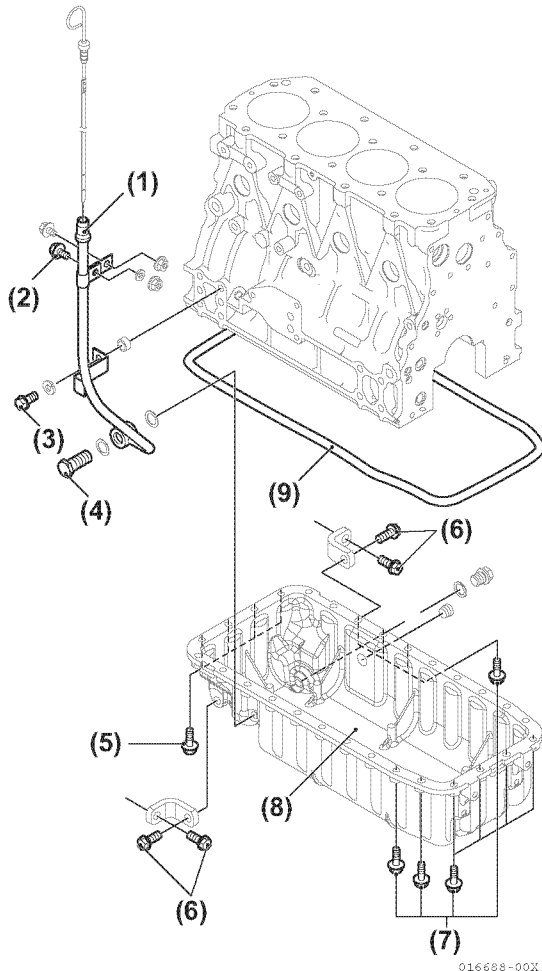

Figure 8-10

3. Remove bolts **(Figure 8-10, (5),(6))** that secure oil sump to flywheel housing.
4. Remove bolts **(Figure 8-10, (7))** securing oil sump to cylinder block.
5. Remove oil sump **(Figure 8-10, (8))** and gasket **(Figure 8-10, (9))**.

6. Clean gasket surfaces of old gasket material.
7. Install oil sump with a new gasket.
8. Tighten oil sump bolts beginning at the center and working alternately toward each end. Tighten bolts to 22.5-28.5 N·m (16.6-21.0 lb-in).
9. If removed, install oil drain plug and tighten to 48.9-58.9 N·m (36.1-43.4 lb-ft).
10. Fill engine with clean lubricating oil.
11. Run engine and check for leaks.
12. Check oil level and add as necessary.

Engine Oil Pump

The oil pump contains no serviceable parts. If the oil pump is damaged, it must be replaced as an assembly.

Remove Engine Oil Inlet Pipe

1. Drain oil from oil sump.
2. Remove oil sump. See **Figure 5-44** on page 5-44.
3. Remove bolts (**Figure 8-11, (1)**), (**Figure 8-12, (1)**). Remove oil inlet pipe (**Figure 8-11, (2)**), (**Figure 8-12, (2)**) and gasket (**Figure 8-11, (3)**), (**Figure 8-12, (3)**).

3JH4E Engine

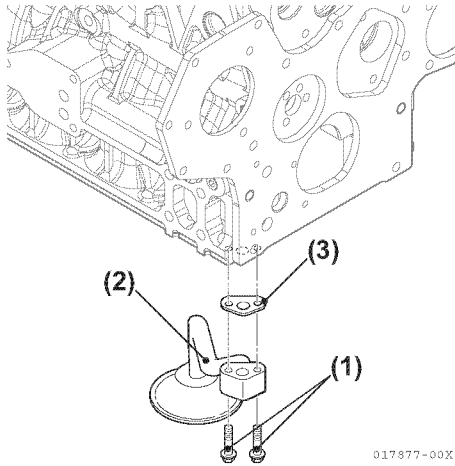

Figure 8-11

4JH4AE, 4JH4-TE and 4JH4-HTE Engines

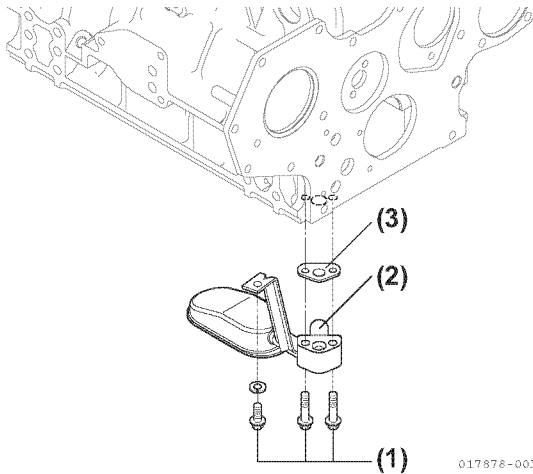

Figure 8-12

Remove Engine Oil Pump

3JH4E and 4JH4AE Engines

The trochoid type lubricating oil pump is mounted in the gear case, and the inner rotor (**Figure 8-13, (1)**) is driven by the crankshaft (**Figure 8-13, (2)**).

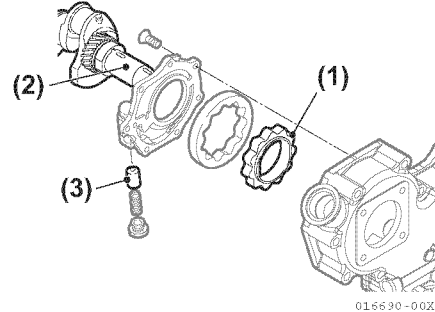

Figure 8-13

The lubricating oil pump assembly with drive gear (**Figure 8-14, (1)**) is driven by the crank gear (**Figure 8-14, (2)**). The lubricating oil pump is fitted with an oil pressure control valve (**Figure 8-13, (3)**), (**Figure 8-14, (3)**).

4JH4-TE and 4JH4-HTE Engines

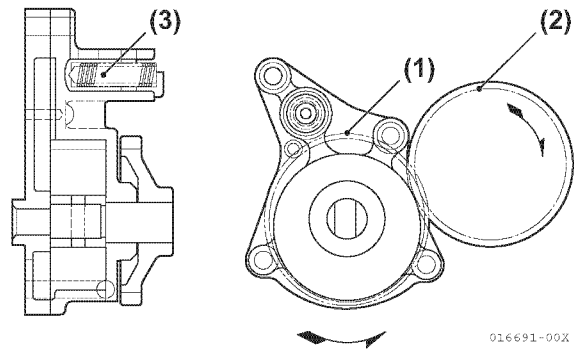

Figure 8-14

1. Remove crankshaft pulley. See **Figure 5-45** on page 5-44.

2. Remove gear case from gear case flange. See **Figure 5-47** on page 5-45.
3. Remove engine oil pump:

3JH4E / 4JH4AE - Remove pump cover from gear case. Do not disassemble inner / outer rotors, and check that pump rotates smoothly.

4JH4-TE / 4JH4-HTE - Remove lubricating oil pump assembly from gear case flange. Do not disassemble inner / outer rotors, and check that pump rotates smoothly.
4. The oil pressure control valve plug is coated with adhesive and screwed in, so it can not be disassembled. These parts cannot be reused after disassembling. Replace control valve assembly as necessary.

Checking Lubricating Oil Pump

Figure 8-15 shows the examples of lubricating oil pump of 3JH4E and 4JH4AE. This procedure is identical for the 4JH4-TE and 4JH4-HTE.

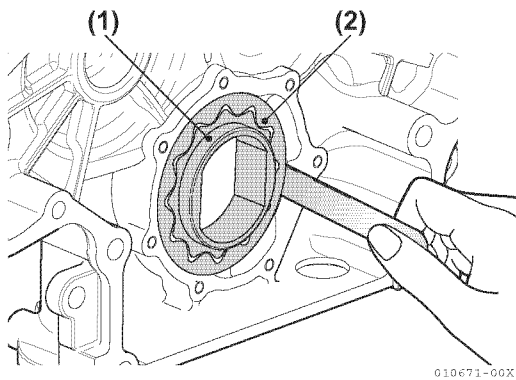

Figure 8-15

- 1 – Inner Rotor
- 2 – Outer Rotor

1. Using feeler gauges, measure the clearance between the outer rotor (**Figure 8-15 (2)**) and the pump case.

Outside Clearance

Model	Standard	Limit
3JH4E/4JH4AE	0.12 - 0.21 mm (0.0047 - 0.0083 in.)	0.30 mm (0.012 in.)
4JH4-TE/4JH4-HTE	0.09 - 0.16 mm (0.0035 - 0.0063 in.)	-

2. Using feeler gauges, measure the clearance between the outer rotor (**Figure 8-15 (2)**) and the inner rotor (**Figure 8-15 (1)**).

Inside Clearance

Model	Standard	Limit
3JH4E/4JH4AE	-	0.16 mm (0.063 in.)
4JH4-TE/4JH4-HTE	-	0.16 mm (0.063 in.)

To measure side clearance of outer rotor:

3. Place a right-angle gauge against the pump body and insert a feeler gauge (**Figure 8-16**).

Side Clearance

Model	Standard	Limit
3JH4E/4JH4AE	0.02 - 0.07 mm (0.0008 - 0.0028 in.)	0.12 mm (0.0047 in.)
4JH4-TE/4JH4-HTE	0.05 - 0.10 mm (0.0020 - 0.0039 in.)	0.15 mm (0.0059 in.)

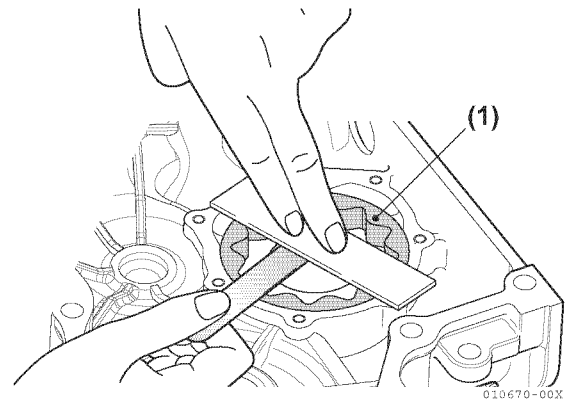

Figure 8-16

- 1 – Outer Rotor

4. Inner rotor and gear boss clearance for 3JH4E and 4JH4AE (Figure 8-17).

Item	Part	Standard Dimension	Standard Clearance	Standard Clearance Limit
Inside Clearance of Inner Rotor	Gear Boss Diameter	53.05 - 53.15 mm (2.089 - 2.093 in.)	0.3 - 0.5 mm (0.012 - 0.020 in.)	0.6 mm (0.024 in.)
	Rotor Inner Diameter	53.45 - 53.55 mm (2.104 - 2.108 in.)		
Width Across Flat Clearance of Inner Rotor	Width Across Flat of Gear Boss	49.45 - 49.75 mm (1.947 - 1.959 in.)	0.2 - 0.6 mm (0.008 - 0.024 in.)	0.7 mm (0.028 in.)
	Width Across Flat Rotor	49.95 - 50.05 mm (1.967 - 1.970 in.)		

3JH4E and 4JH4AE Engines

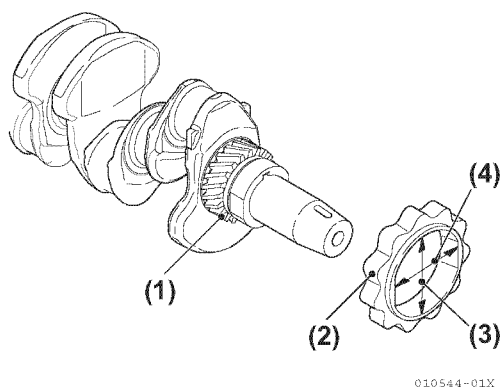

Figure 8-17

- 1 – Crank Gear
- 2 – Inner Rotor
- 3 – Inside Clearance of Inner Rotor
- 4 – Width Across Flat of Rotor

Install Engine Oil Pump

Note: Always check if pump rotates smoothly after installation on gear case. Running engine when pump rotation is stiff may cause damage to the pump.

1. Apply lubrication oil to outer and inner rotors .
2. Install oil pump assembly:
 3JH4E / 4JH4AE - Assemble outer rotor so that the end face mark is on the cover side when inserting outer rotor in gear case.

 4JH4-TE / 4JH4-HTE - Install lubrication oil pump assembly to gear case flange.

3. Secure pump cover to gear case for 3JH4 and 4JH4AE to a torque of 5.4 - 8.4 N·m (4.0 - 6.2 lb-ft).
4. When replacing lubrication oil pump, replace whole assembly.
5. Install oil sump. See *Remove and Install Engine Oil Sump* on page 8-11.
6. Fill crankcase to proper level with new lubrication oil.

Piston Cooling Oil Nozzle Check

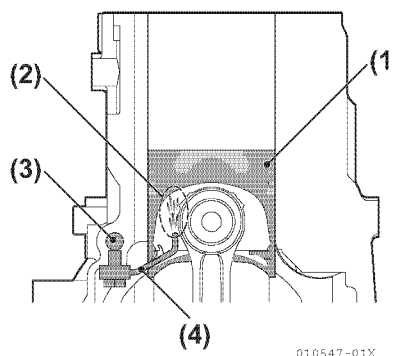

Figure 8-18

- 1 – Piston
- 2 – Splash
- 3 – Cylinder Block Main Gallery
- 4 – Piston Cooling Oil Nozzle

1. Check the nozzle end hole (diameter 1.8 mm [0.071 in.]) for dust or other foreign matter (Figure 8-18).
2. Check the brazed portion of the copper tube for fracture due to vibration.

Section 9

TURBOCHARGER

	Page
Safety Precautions	9-3
Introduction.....	9-3
Specifications	9-3
Turbocharger Components	9-4
Special Service Tools.....	9-5
Washing the Turbocharger Blower.....	9-5
Clean Air Cleaner	9-6
Turbocharger Service.....	9-6

This Page Intentionally Left Blank

SAFETY PRECAUTIONS

Before you service the engine turbocharger, review the *Safety Section on 2-1*.

INTRODUCTION

This section of the *Service Manual* describes the removal, inspection and installation of turbochargers used on 4JH4-TE and 4JH4-HTE engines.

SPECIFICATIONS

Turbocharger Specifications

Model	4JH4-TE	4JH4-HTE
	RHB52W (IHI)	
Spec. No.	7000VNHP12NFW	7000VNHP15NFW
Turbine	Radial flow type	
Compressor	Centrifugal type	
Lubricating	Engine lubricating oil	
Bearing	Fuel floating	
Cooling	Freshwater cooling	
Dry Mass	3.6 kg (7.9 lb)	

TURBOCHARGER COMPONENTS

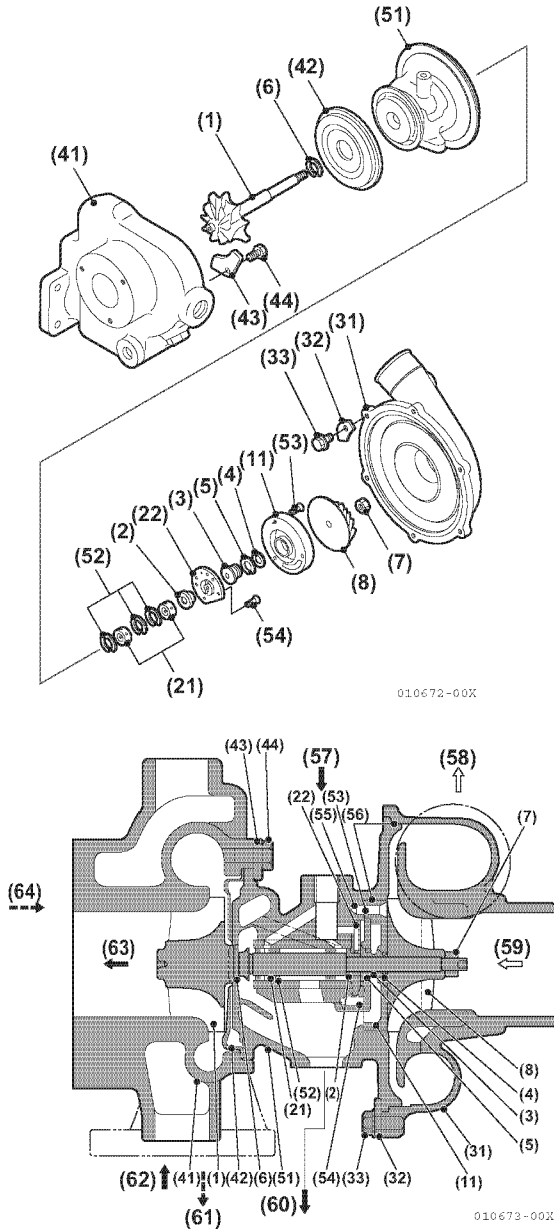

Figure 9-1

Sectional View and Tightening Torque

No.	Components	Q'ty	Tightening Torque Kgf·cm (N·cm)
1	Turbine Shaft	1	
2	Thrust Bushing	1	
3	Oil Thrower	1	
• 4	Compressor Side Seal Ring (Small)	1	
• 5	Compressor Side Seal Ring (Large)	1	
• 6	Turbine Side Seal Ring	1	
7	Shaft End Nut / (Left Hand Thread)	1	20±2 (196±19)
8	Compressor Impeller	1	
11	Seal Plate	1	
21	Floating Bearing	2	
22	Thrust Bearing	1	
31	Compressor Housing	1	
32	Compressor Side Plate Washer	4	
33	Hexagon Bolt With Flange	6	48±5 (471±49)
41	Turbine Housing	1	
42	Thermal Insulation Plate	1	
43	Turbine Side Plate Washer	5	
44	Hexagon Bolt	5	285±5 (2796±49)
51	Bearing Housing	1	
52	Retaining Ring	3	
• 53	TORXT Screw Bolt	3	13±1 (128±10)
• 54	TORXT Screw Bolt	4	13±1 (128±10)
55	Loctite	-	
56	Liquid Gasket	-	Three-Bond 1207
57	Oil Inlet		
58	Air Outlet		
59	Air Inlet		
60	Oil Outlet		
61	Coolant Outlet		
62	Gas Inlet		
63	Gas Outlet		
64	Coolant Inlet		

• Non-reusable part.

SPECIAL SERVICE TOOLS

Note: The tool numbers used in this section are either Yanmar or IHI part numbers. Yanmar part numbers are referred to as **Yanmar Part No.** and IHI part numbers are referred to as **OEM Part No.** Tools not having part numbers must be obtained locally.

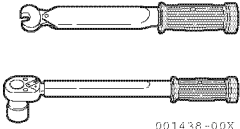
No.	Instrument Name	Application	Illustration
1	Torque Wrench	For tightening nuts and bolts to the specified torque	 001438-00X

WASHING THE TURBOCHARGER BLOWER

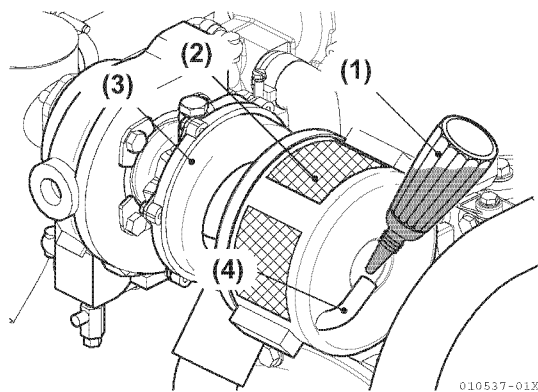

Figure 9-2

- 1 – Blower Wash
- 2 – Intake Silencer
- 3 – Turbocharger
- 4 – Inlet

When engine speed seems sluggish or the exhaust color poor, the blades of the turbocharger blower may be dirty. Wash the blower using the following procedure:

1. Prepare blower wash (liquid detergent), freshwater and a small pitcher.
Blower wash (4L)
Parts code: 974500-00400
2. Put the clutch in neutral and run the engine at high speed, 2500-3000 minimum (rpm).
3. Slowly pour approximately 50cc (1.7 oz) of blower wash into the inlet hole of the intake silencer over a period of about 10 seconds.
4. After about 3 minutes, pour in approximately 50cc (1.7 oz) of freshwater in the same manner over a period of about 10 seconds.
5. After operating the engine for about 10 minutes, check the boost pressure and power output. If there is no improvement after washing the blower, repeat the washing process several times. *NOTICE: Do not pour in a large amount of blower wash at one time. This can damage the blower blades and cause water hammer in the combustion chamber and cause damage.*

CLEAN AIR CLEANER

Disassemble the intake silencer (air cleaner) periodically for inspection. With use, the air filter will become clogged over a period of time. A clogged air filter decreases the volume of intake air, may cause decreased power output and affect emissions.

1. Disassemble the air cleaner and clean it with a neutral detergent.
2. Reassemble after it is completely dry.

Turbocharger Service

Removal

NOTICE: Ensure the work area is clean at all times when working on the turbocharger. Never leave connections for oil inlets or outlets unprotected. Dust and debris in the turbocharger bearing housing will damage the turbocharger.

1. Remove intake pipe for 4JH4-TE (**Figure 9-3, (1)**) and intake pipes (turbine, intercooler, intake manifold) for 4JH4-HTE (**Figure 9-4, (1)**).

4JH4-TE Engine

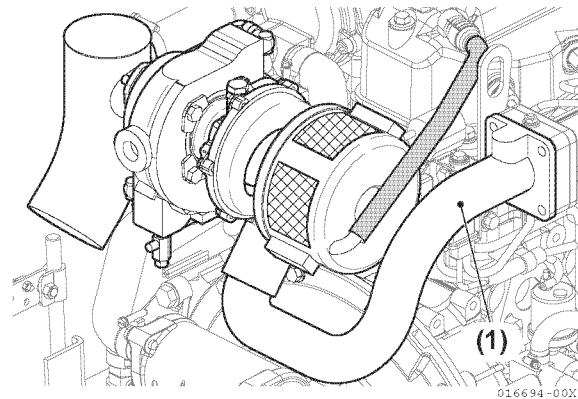

Figure 9-3

4JH4-HTE Engine

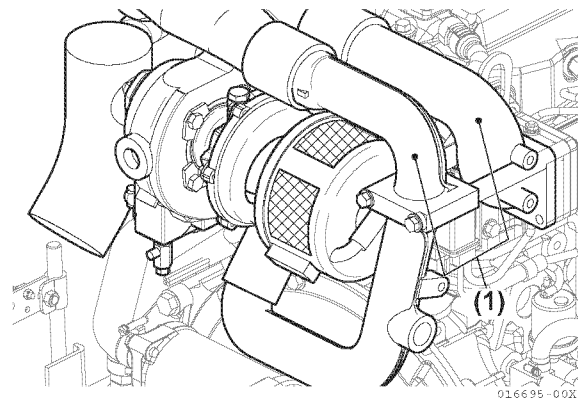

Figure 9-4

- Remove mixing elbow for 4JH4-TE (Figure 9-5, (1)) and 4JH4-HTE (Figure 9-6, (1)). See *Remove cooling system components from engine. on page 5-34.*

4JH4-TE Engine

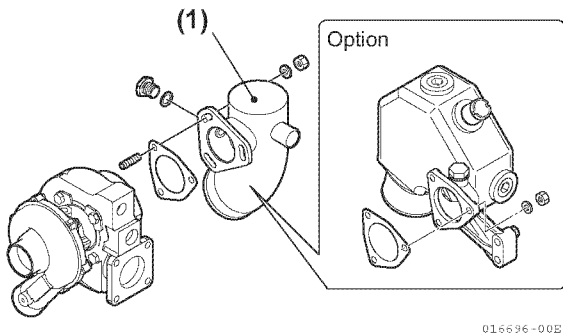

Figure 9-5

4JH4-HTE Engine

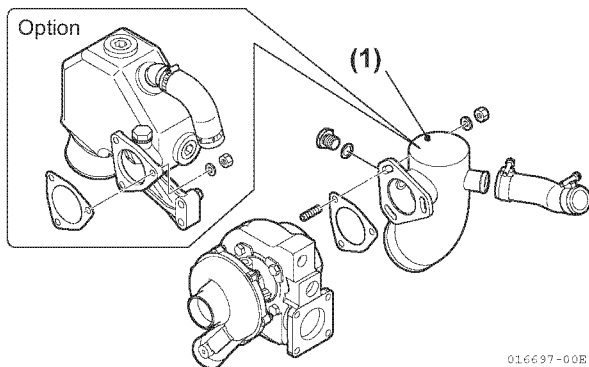

Figure 9-6

- Remove the air cleaner for the 4JH4-TE (Figure 9-7, (1)) and the 4JH4-HTE (Figure 9-8, (1)).

4JH4-TE Engine

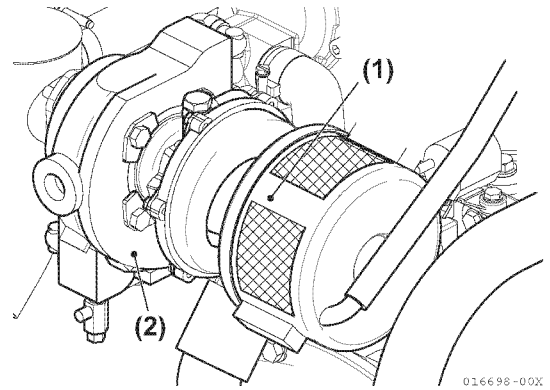

Figure 9-7

4JH4-HTE Engine

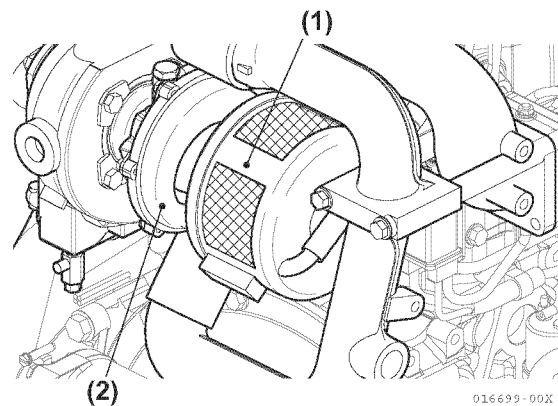

Figure 9-8

- Remove turbocharger for 4JH4-TE (Figure 9-7, (2)) and 4JH4-HTE (Figure 9-8, (2)).
 - Remove four nuts and washers (Figure 9-9, (2),(3)) and remove turbocharger (Figure 9-9, (1)) from heat exchanger body (Figure 9-9, (5)).

- Remove gasket (Figure 9-9, (4)).

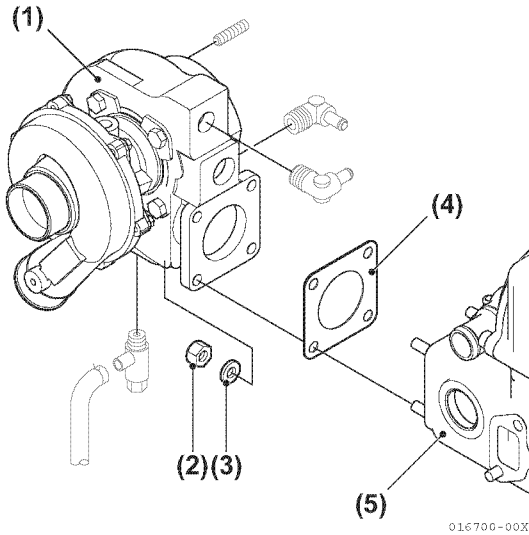

Figure 9-9

Check and Service Data

Service Interval

Item	Check Cycle
Check on Conditions of Turbine Shaft Rotation	Every 500 h
Check on Play in The Turbine Shaft	Every 1000 h
Overhaul	Every 4000 h

Check the conditions of turbine shaft rotation by listening for abnormal sounds during rotation. To check using a listening bar, firmly push the end of the bar against the turbocharger case and gradually increase the engine speed.

In the event of a problem with the turbine shaft, a high-pitched sound will be produced every 2 to 3 seconds.

If this sound is heard, the bearing or turbine shaft may be defective. Replace or overhaul the turbocharger.

- Check for:
End play in the turbine shaft
End Play
Service standard: 0.03 to 0.06 mm
(0.001 to 0.002 in.)
Wear limit: 0.09 mm (0.004 in.)
- Check for:
Radial play in the turbine shaft
Service standard: 0.06 to 0.08 mm
(0.002 to 0.003 in.)
Wear limit: 0.17 mm (0.007 in.)

- Check on play in the turbine shaft:
Remove the turbocharger from the engine. Check end play and radial play in the turbine shaft as shown **Figure 9-10** and **Figure 9-11**.

When the turbocharger is dismantled from the engine, cover the oil inlet / outlet with gummed cloth tape.

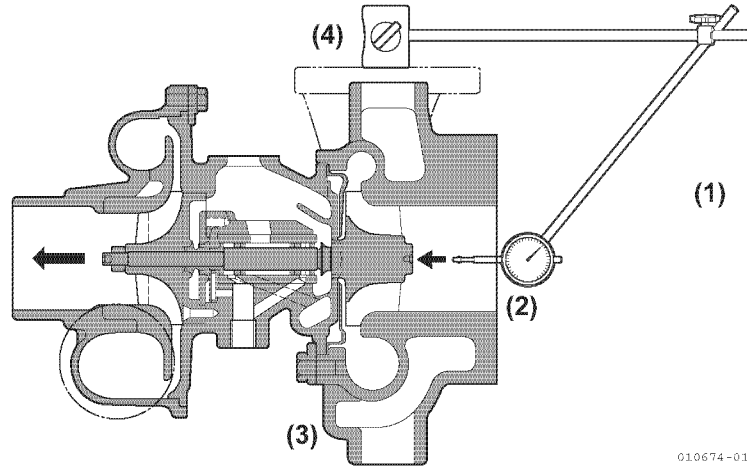

Figure 9-10

- 1 – Move the Turbine Shaft in the Axial Direction
- 2 – Dial Gauge

- 3 – Turbine Housing
- 4 – Magnet Base

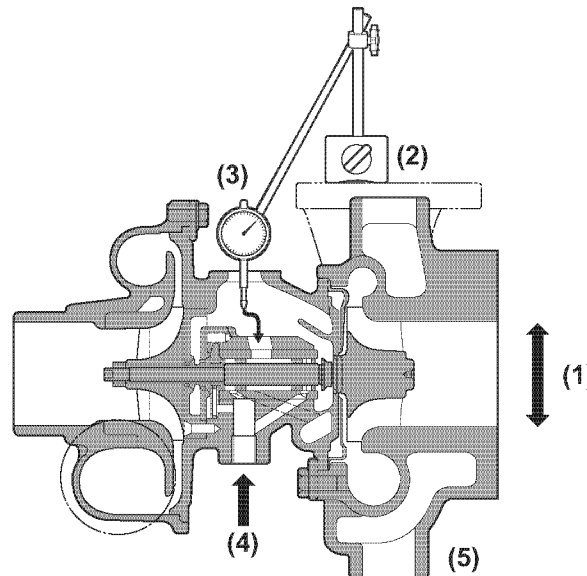

Figure 9-11

- 1 – Move the Turbine Shaft on the Left and Right Sides Simultaneously in the Radial Direction
- 2 – Magnet Base

- 3 – Dial Gauge
- 4 – Oil Inlet
- 5 – Turbine Housing

Cautions During Assembly

This is applied only to the abutment that is nearest the turbine side.

Upper retaining ring is applied only to the abutment that is located nearest the turbine side.

Retaining ring

- Install the abutment as shown in **Figure 9-12**.
- Put the round ring surface on the metal side.

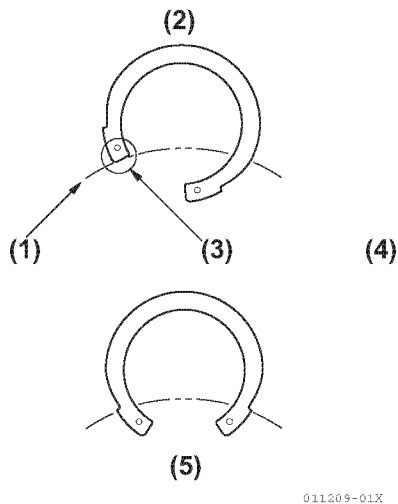

Figure 9-12

- 1 – Oil Inlet
- 2 – Cutter Groove
- 3 – Align Here
- 4 – Viewed from the Turbine Side
- 5 – All Except Upper One Ring

Seal ring on the turbine side

- Put the abutment on the oil inlet side.

Seal ring on the compressor side

- Insert the abutment as shown in **Figure 9-13**.

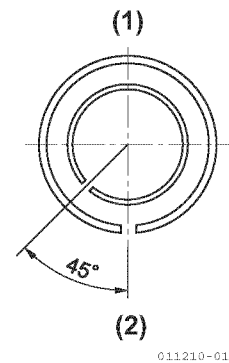

Figure 9-13

- 1 – Oil Inlet
- Viewed from the Compressor Side

Service Standards

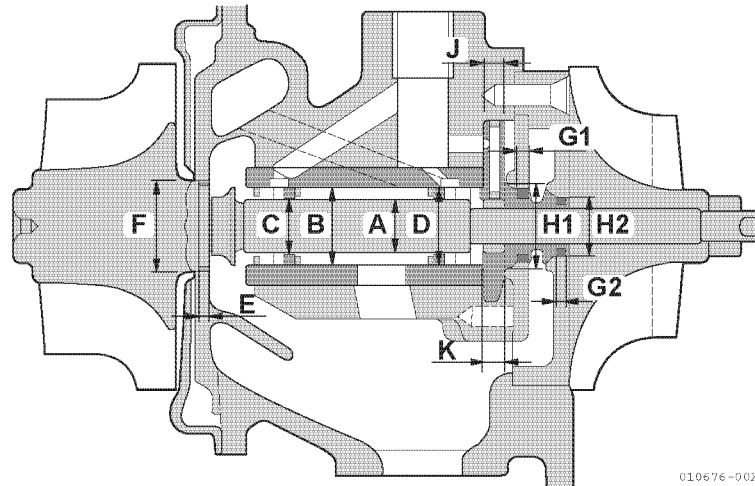

Figure 9-14

	Check Item	Usable Limit	Remarks
Turbine Shaft	Outside diameter (A) of turbine shaft journal	7.98mm (0.314 in.)	-
	Seal ring groove width (E) on turbine side	1.29 (0.0508 in.)	-
	Seal ring groove width (G1) on compressor side	1.31 (0.0516 in.)	-
	Seal ring groove width (G2) on compressor side	1.11 (0.0437 in.)	-
	Turbine shaft run-out	0.011 (0.0004 in.)	-
Bearing	Floating bearing inside diameter (C)	8.04 (0.317 in.)	-
	Floating bearing outside diameter (D)	12.31 (0.485 in.)	-
	Bearing case inside diameter (B)	12.42 (0.489 in.)	-
Thrust Bearing	Thrust bearing width (J)	3.98 (0.157 in.)	-
	Distance (K) between thrust bearing grooves	4.07 (0.160 in.)	-
Seal Ring Inserting Area	Turbine side (bearing housing) (F)	15.05 (0.592 in.)	-
	Compressor side (seal plate) (H1)	12.45 (0.490 in.)	-
	Compressor side (seal plate) (H2)	10.05 (0.396 in.)	-
End play in the Turbine Shaft		0.09 (0.004 in.)	Standard 0.03 to 0.06 (0.001 to 0.002 in.)
Radial Play in the Turbine Shaft		0.17 (0.007 in.)	Standard 0.08 to 0.13 (0.003 to 0.005 in.)

Installation

Note: When installing the turbocharger, replace all gaskets with new ones, change the engine oil and replace the engine oil filter. See *Change Engine Oil, Replace Engine Oil Filter Element and Clean Engine Oil Cooler* on page 8-9.

1. Clean the mounting surfaces of all gasket material.
2. Install the turbocharger with a new gasket (**Figure 9-15, (1)**). Tighten nuts to 22.5 - 28.5 N·m (199-252 lb-in.)
3. Instal air filter (**Figure 9-15, (2)**).
4. Connect the intake pipe (**Figure 9-15, (3),(4)**) and tighten all clamps and bolts securely.
5. Connect lubricating oil lines (**Figure 9-15, (5), (6)**) and tighten all bolts securely.
6. Connect the mixing elbow (**Figure 9-15, (7)**) and seawater drain pipe (**Figure 9-15, (8)**). Tighten all clamps and bolts securely.
7. Start the engine and check for oil leaks.

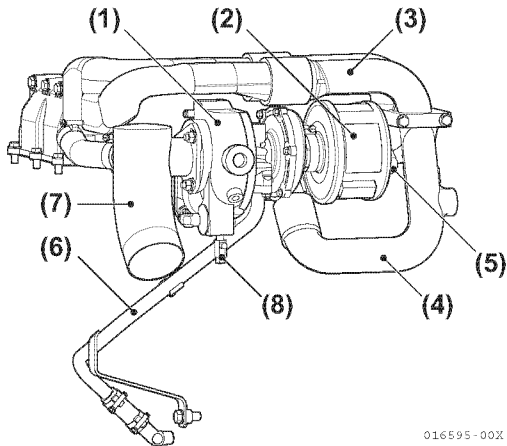

016595-00X

Figure 9-15

Section 10

STARTER MOTOR

	Page
Safety Precautions	10-3
Introduction.....	10-3
Starter Motor Specifications	10-4
General Specifications.....	10-4
Special Torque Chart.....	10-4
Characteristics.....	10-4
Starter Motor Troubleshooting.....	10-5
Starter Motor Service	10-6

This Page Intentionally Left Blank

SAFETY PRECAUTIONS

Before you service the starter motor, read the following safety information and review the *Safety Section on page 2-1*.

WARNING

The safety messages that follow have **WARNING** level hazards. These safety messages describe a hazardous situation which, if not avoided, *could* result in death or serious injury.

ALWAYS turn off the battery switch (if equipped) or disconnect the negative (-) battery cable before servicing the electrical system.

ALWAYS check the electrical harnesses for cracks, abrasions, and damaged or corroded connectors. ALWAYS keep the connectors and terminals clean.

NOTICE

Indicates a situation which can cause damage to the machine, personal property and / or the environment or cause the equipment to operate improperly.

NEVER engage the starter motor while the engine is running. Damage to the starter motor pinion and / or ring gear will result.

INTRODUCTION

This section of the *Service Manual* covers servicing of starter motor on 3JH4, 4JH4AE, 4JH4-TE and 4JH4-HTE engines.

STARTER MOTOR SPECIFICATIONS

General Specifications

Item	Yanmar Part No.	HITACHI Model No.
	129608-77011	S114-817A
Nominal Power	1.4 kW (1.9 hp)	
Nominal Voltage	12 V	
Test Voltage	-	
Maximum Operating Temperature	80 °C (176°F)	
Rotation	Clockwise	
Maximum Current Draw at 11V	90 A	
Mass	3.0 kg (6.6 lb)	

Special Torque Chart

Item	Specification
Battery Positive (+) Cable: B Terminal	7.4 - 9.8 N·m (65 - 87 lb-in.)
Solenoid Primary Wire: S and M Terminal	3.0 - 4.2 N·m (26 - 37 lb-in.)

Characteristics

Standard Performance 12V 1.4kW

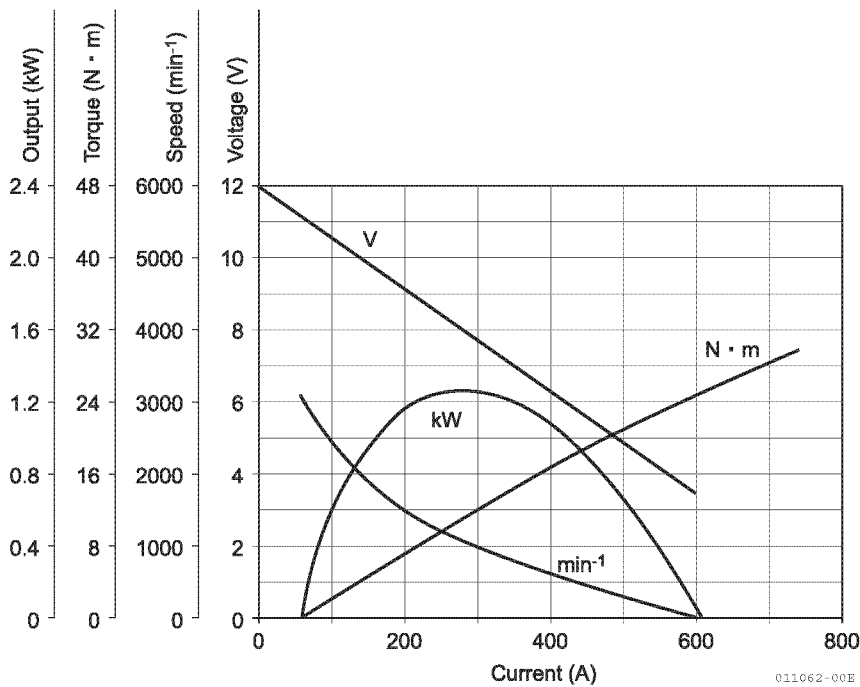

Figure 10-1

STARTER MOTOR TROUBLESHOOTING

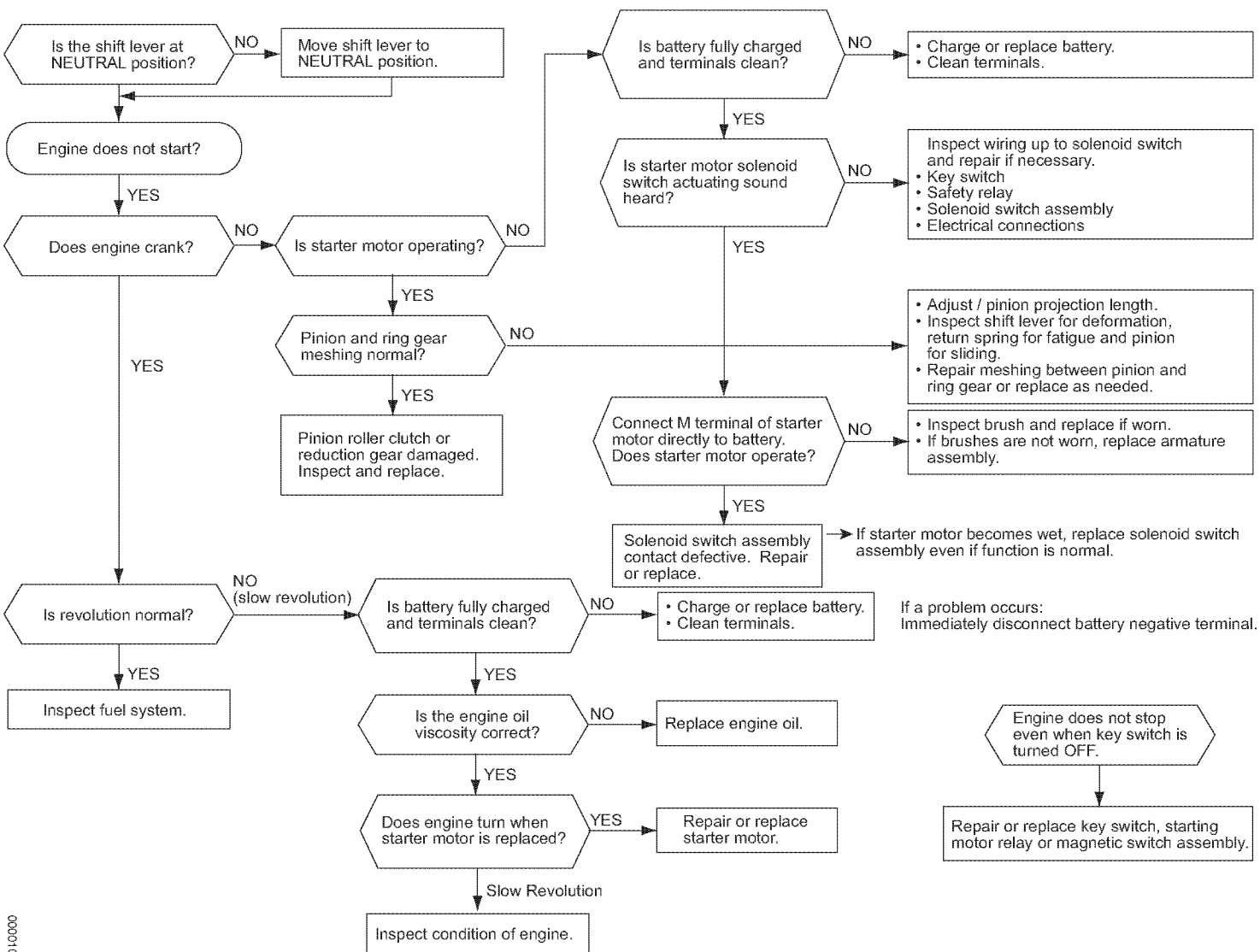

Figure 10-2

0000102

STARTER MOTOR SERVICE

1. Disconnect the negative (-) battery cable (Figure 10-3, (1)) and turn the battery master switch OFF (if equipped) (Figure 10-3, (2)).

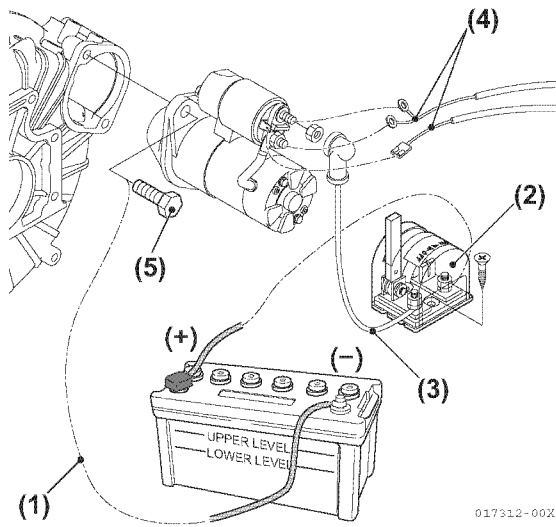

Figure 10-3

2. Disconnect positive (+) cable (Figure 10-3, (3)) and primary wires (Figure 10-3, (4)).
3. Remove bolts (Figure 10-3, (5)) securing the starter motor to the flywheel housing.
4. Carefully remove the starter motor. *NOTICE: Check the starter pinion for damage. If the starter pinion is damaged, check the flywheel ring gear for damage.*
5. Clean the starter mounting area of the flywheel housing.
6. Install the starter motor.
7. Clean the cable connections.
8. Connect the cable and primary wires to the appropriate terminals of the starter and connect positive (+) battery cable.
9. Connect the negative (-) battery cable and return the master switch to the ON position.
10. Operate the starter to verify operation.

Section 11

ALTERNATOR

	Page
Safety Precautions	11-3
Introduction.....	11-3
Specifications	11-4
General Specifications (Standard).....	11-4
General Specifications (Optional for 3JH4E, 4JH4-TE and 4JH4-HTE).....	11-4
Special Torque Chart.....	11-5
Wiring Diagram.....	11-6
Output Characteristics	11-8
Alternator Service	11-9
Replace V-Belt.....	11-9
Remove and Install Alternator	11-9

This Page Intentionally Left Blank

SAFETY PRECAUTIONS

Before you service the alternator, read the following safety information and review the *Safety Section on page 2-1*.

WARNING

The safety messages that follow have **WARNING** level hazards. These safety messages describe a hazardous situation which, if not avoided, *could* result in death or serious injury.

ALWAYS turn off the battery switch (if equipped) or disconnect the negative (-) battery cable before servicing the electrical system.

ALWAYS check the electrical harnesses for cracks, abrasions, and damaged or corroded connectors. ALWAYS keep the connectors and terminals clean.

NOTICE

Indicates a situation which can cause damage to the machine, personal property and / or the environment or cause the equipment to operate improperly.

NEVER operate the engine if the alternator is producing unusual sounds. Damage to the alternator will result.

NEVER remove the positive (+) battery cable from alternator terminal B while the engine is operating. Damage to the alternator will result.

NEVER turn the battery switch OFF while the engine is operating. Damage to the alternator will result.

NEVER use a high-pressure wash directly on the alternator. Water will damage the alternator and result in inadequate charging.

INTRODUCTION

This section of the *Service Manual* covers servicing of starter motor on 3JH4, 4JH4AE, 4JH4-TE and 4JH4-HTE engines.

SPECIFICATIONS**General Specifications (Standard)**

Item	Specification
Yanmar Code	119573-77201
Manufacturer	HITACHI
Model	LR180-03C
Nominal Voltage	12V
Nominal Output	80A
Rotation	Clockwise (viewed from pulley end)
Rated Speed	5000 (rpm)

General Specifications (Optional for 3JH4E, 4JH4-TE and 4JH4-HTE)

Item	Specification
Yanmar code	12871-77200
Manufacturer	HITACHI
Model	LR160-741
Nominal Voltage	12V
Nominal Output	60A
Rotation	Clockwise (viewed from pulley end)
Rated Speed	5000 (rpm)

Special Torque Chart

Item	Specification
Alternator Mounting Bolts	22.5 - 28.5 N·m (16.6 - 21.0 lb-ft)
Positive (+) Cable Nut	3.7 - 5.0 N·m (33 - 44 lb-in.)

Wiring Diagram

Standard Alternator - 12 Volt / 80 Amps

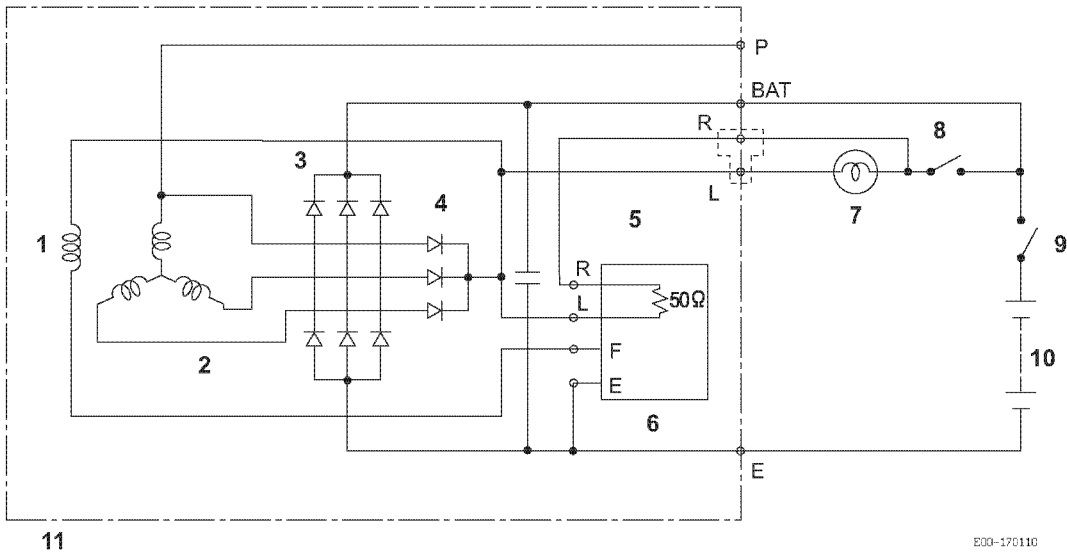

Figure 11-1

- | | |
|-----------------------------|-------------------------|
| 1 – Rotor Coil | 7 – Charge Lamp 12V3.4W |
| 2 – Stator Coil | 8 – Key Switch |
| 3 – Diode | 9 – Battery Switch |
| 4 – Sub-Diode | 10 – Battery |
| 5 – Condenser (3.2 μ F) | 11 – Alternator |
| 6 – IC Regulator | |

Optional Alternator - 12 Volt / 60 Amps (for 3JH4E, 4JH4-TE and 4JH4-HTE)

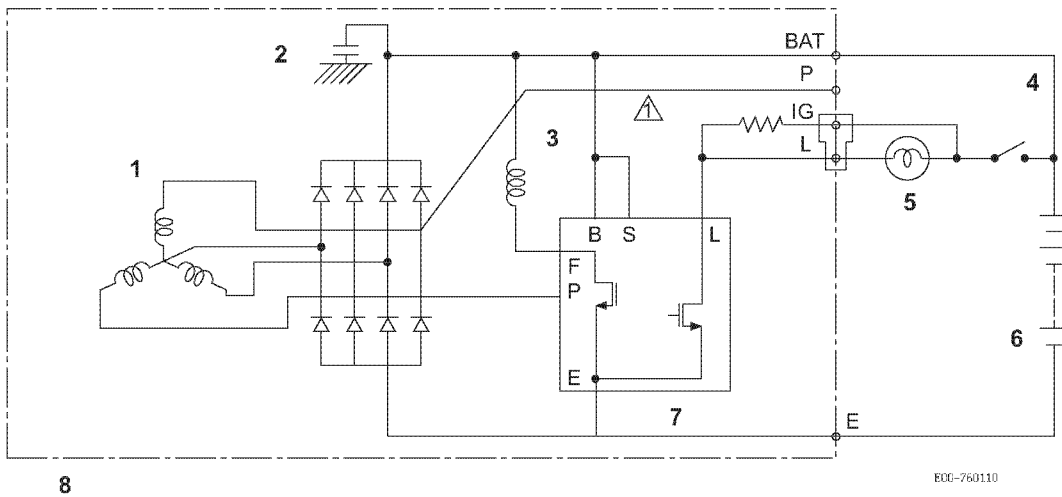

Figure 11-2

- | | |
|---------------------------|-------------------------|
| 1 – Stator Coil | 5 – Charge Lamp 12V3.4W |
| 2 – Condenser 2.2 μ F | 6 – Battery |
| 3 – Rotor Coil | 7 – IC Regulator |
| 4 – Key Switch | 8 – Alternator |

Output Characteristics

Standard Alternator - 12 Volt / 80 Amps

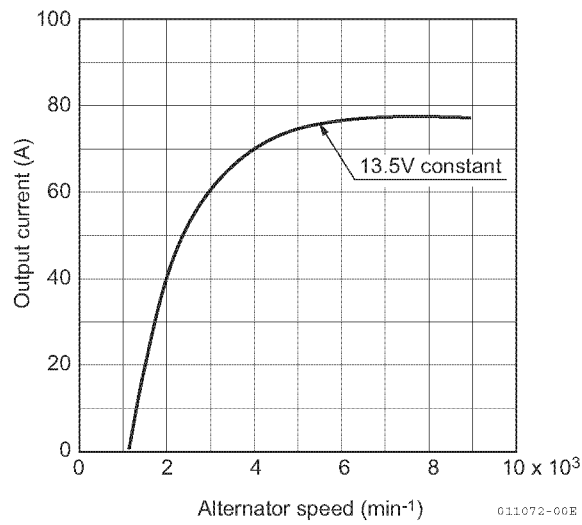

Figure 11-4

Optional Alternator - 12 Volt / 60 Amps (for 3JH4E, 4JH4-TE and 4JH4-HTE)

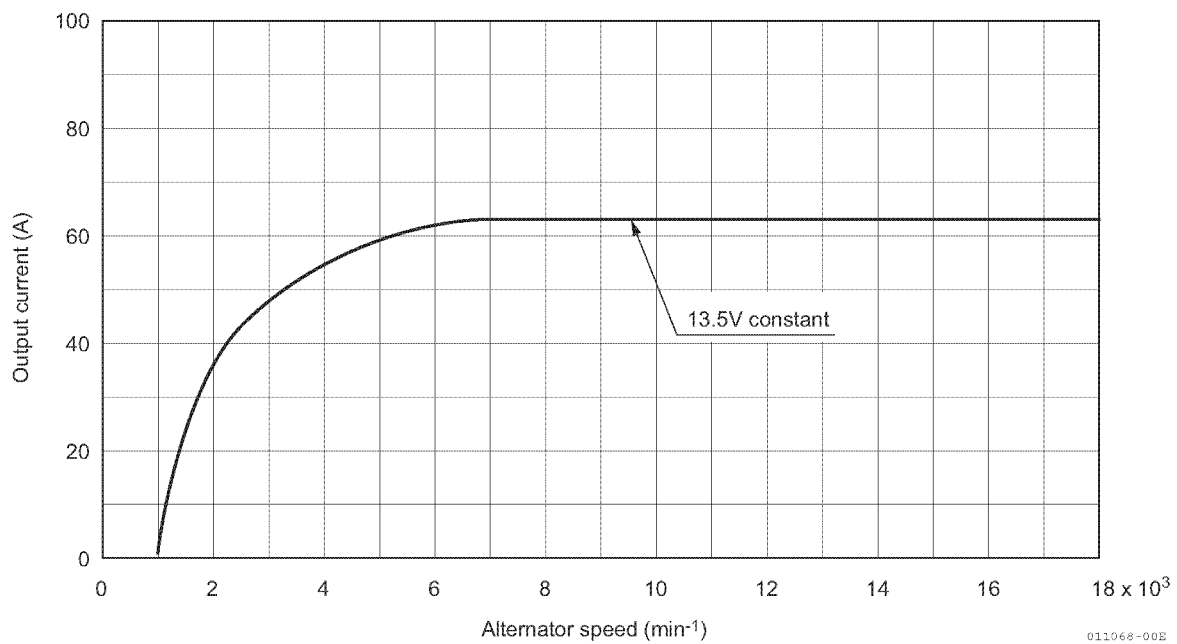

Figure 11-5

ALTERNATOR SERVICE

Replace V-Belt

1. Disconnect negative (-) battery cable.
2. Remove the V-belt cover.
3. Remove the V-belt. *See Replace Coolant Pump Belt and Pulley on page 7-23*

Belt Routing

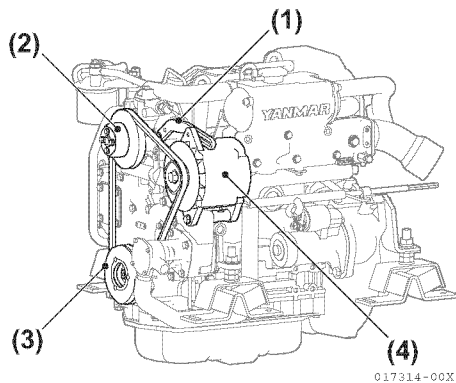

Figure 11-6

- 1 – Belt Adjuster
- 2 – Coolant Pump Pulley
- 3 – Crankshaft Pulley
- 4 – Alternator

4. Loosen the alternator adjuster bolt (Figure 11-7, (1)) and relieve V-belt tension. Remove the V-belt. *NOTICE: If belt is to be reused, note direction of travel and install in same direction of travel.*

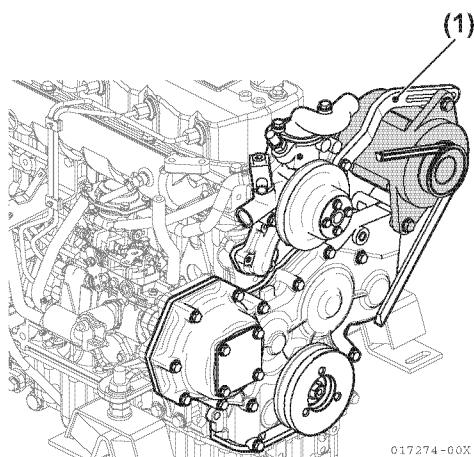

Figure 11-7

5. Installation is the reverse of removal. **CAUTION! ALWAYS use care not to pinch a finger between belt and pulley while installing belt. Failure to comply may result in minor or moderate injury. NOTICE: Ensure belt correctly engages all grooves of each pulley. Failure to do so will lead to premature belt failure.**

Remove and Install Alternator

1. Disconnect negative (-) battery cable.
2. Remove the V-belt cover.
3. Remove the alternator belt. *See Replace Coolant Pump Belt and Pulley on page 7-23.*
4. Disconnect the positive (+) cable (Figure 11-8, (1)) from alternator E terminal.

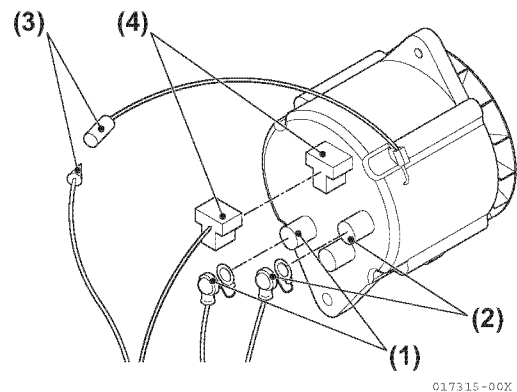

Figure 11-8

- 1 – E Terminal
 - 2 – BAT Terminal
 - 3 – Connector for IC Regulator
 - 4 – Connector for Speed Sensor (If Used)
5. Disconnect the connector (Figure 11-8, (2)) from alternator BAT terminal.
 6. Disconnect wire connector for IC regulator (Figure 11-8, (3)).
 7. Disconnect the wire connector for the speed sensor, if used (Figure 11-8, (4)).

8. Remove two bolts (**Figure 11-9, (1)**) and remove the alternator from engine.

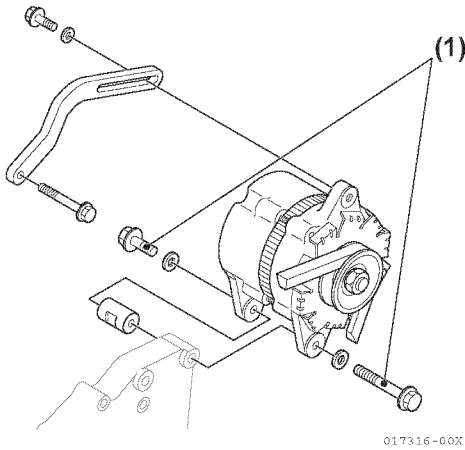

Figure 11-9

9. Install the alternator and tighten mounting bolts to 22.5 - 28.5 N·m (16.5 - 21.0 lb-ft).
10. Connect cables to alternator. Tighten positive (+) cable nut to 5.9 - 6.9 N·m (3.7 - 5.0 N·m [33 - 44 lb-in.]).
11. Install the V-belt. See *Replace Coolant Pump Belt and Pulley* on page 7-23.
12. Install the V-belt cover.
13. Connect negative (-) battery cable to the battery.

Section 12

ELECTRICAL

	Page
Safety Precautions	12-3
Introduction.....	12-3
Component Locations	12-4
Sensor and Switch Locations	12-4
Wiring Diagram.....	12-6
3JH4E B-Type Instrument Panel.....	12-6
3JH4E - B-Type Instrument Panel.....	12-7
4JH4AE - B-Type Instrument Panel	12-8
4JH4AE - B-Type Instrument Panel	12-9
4JH4-TE / 4JH4-HTE with Panel B x B Type	12-10
4JH4-TE / 4JH4-HTE with Panel B x B Type Instrument Panel	12-11
3JH4E - C-Type Instrument Panel.....	12-12
3JH4E - C-Type Instrument Panel.....	12-13
4JH4AE - C-Type Instrument Panel	12-14
4JH4AE - C-Type Instrument Panel	12-15
4JH4-TE / 4JH4-HTE with Panel C x B Type	12-16
4JH4-TE / 4JH4-HTE with Panel C x B Type Instrument Panel	12-17
Instrument Panel	12-18
B-Type Instrument Panel (Selectable Optional)	12-18
C-Type Instrument Panel (Selectable Optional)	12-19
Function Description - Warning Devices	12-20
Oil Pressure Alarm	12-20
Sending Unit for Lubricating Oil Pressure Gauge.....	12-21
Coolant Temperature Alarm	12-22
Sending Unit for the Coolant Temperature Gauge	12-23
Air Heater (Standard for 4JH4AE, 4JH4-TE and 4JH4-HTE. Optional for 3JH4E)	12-24
Electric Engine Stop Solenoid	12-25

This Page Intentionally Left Blank

SAFETY PRECAUTIONS

Before you service the electrical components, read the following safety information and review the *Safety Section on page 2-1*.

INTRODUCTION

This section of the *Service Manual* describes the operation of and procedures to replace the components of the electrical system as used on the Yanmar 3JH4, 4JH4AE, 4JH4-TE and 4JH4-HTE marine engines.

COMPONENT LOCATIONS

Sensor and Switch Locations

Note: 3JH4E Engine electrical system shown.

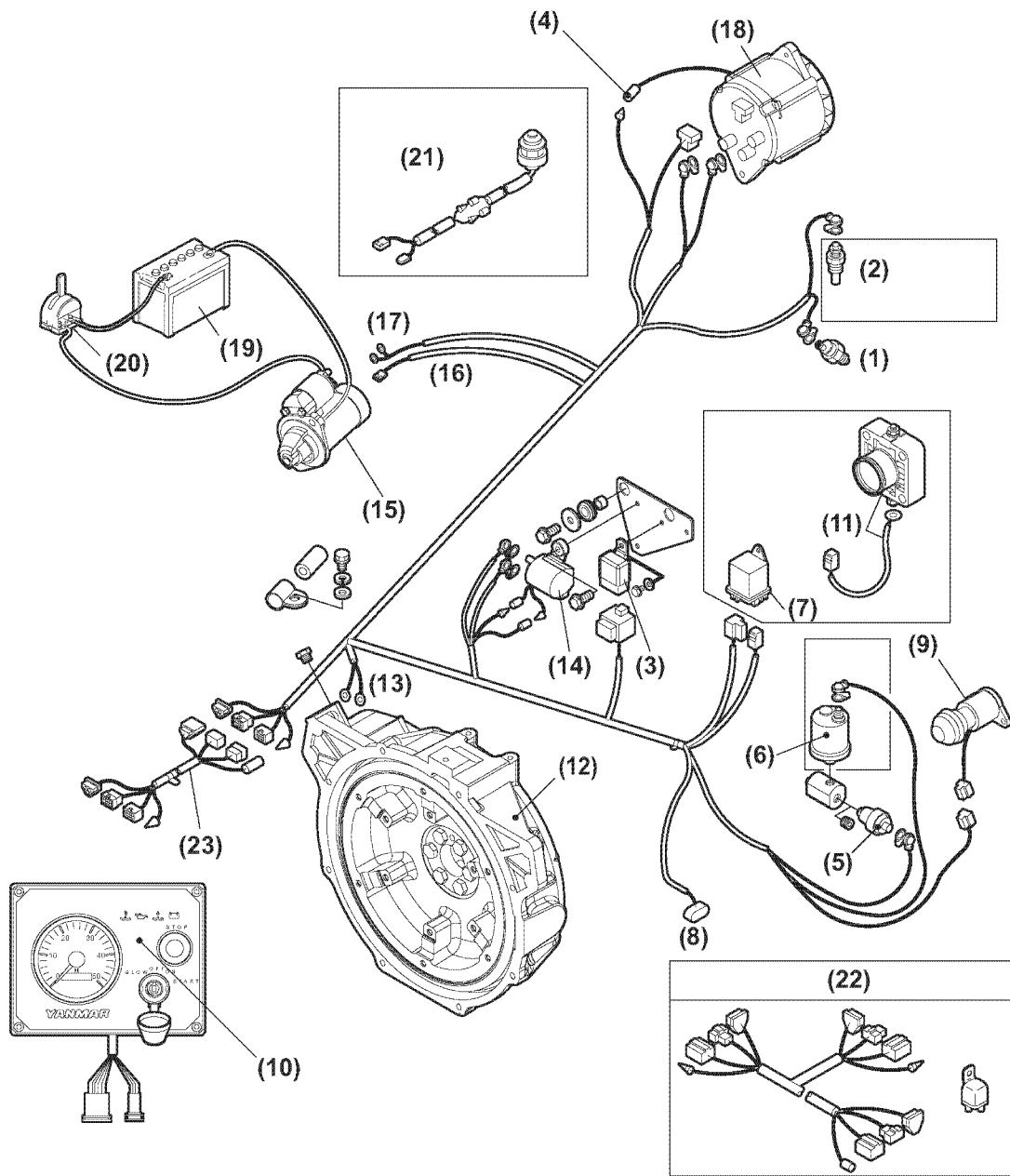

310-526010

Figure 12-1

- | | |
|---|--|
| 1 – Coolant Temperature Switch | 12 – Flywheel Housing |
| 2 – Coolant Temperature Sensor (Optional) | 13 – Ground Bolt |
| 3 – Magnetic Relay (Safety Relay) | 14 – Magnetic Relay |
| 4 – Speed Sensor (Alternator) | 15 – Starting Motor |
| 5 – Oil Pressure Sensor | 16 – Starter S Terminal |
| 6 – Oil Temperature Sensor (Optional) | 17 – Starter B Terminal |
| 7 – Air Heater (4JH Series Standard and 3JH4E
Optional) | 18 – Alternator |
| 8 – Sail Drive Seal Water Leakage Sensor | 19 – Battery |
| 9 – Fuel Stop Solenoid | 20 – Battery Switch |
| 10 – Instrument Panel | 21 – Neutral Safety Switch (Fitting to Marine
Gear, Optional) |
| 11 – Air Heater Intake Manifold (Optional for
3JH4E, Standard for 4JH4AE, 4JH4-TE and
4JH4-HTE) | 22 – 2-Place Extension (Optional) |
| | 23 – Extension Wire Harness |

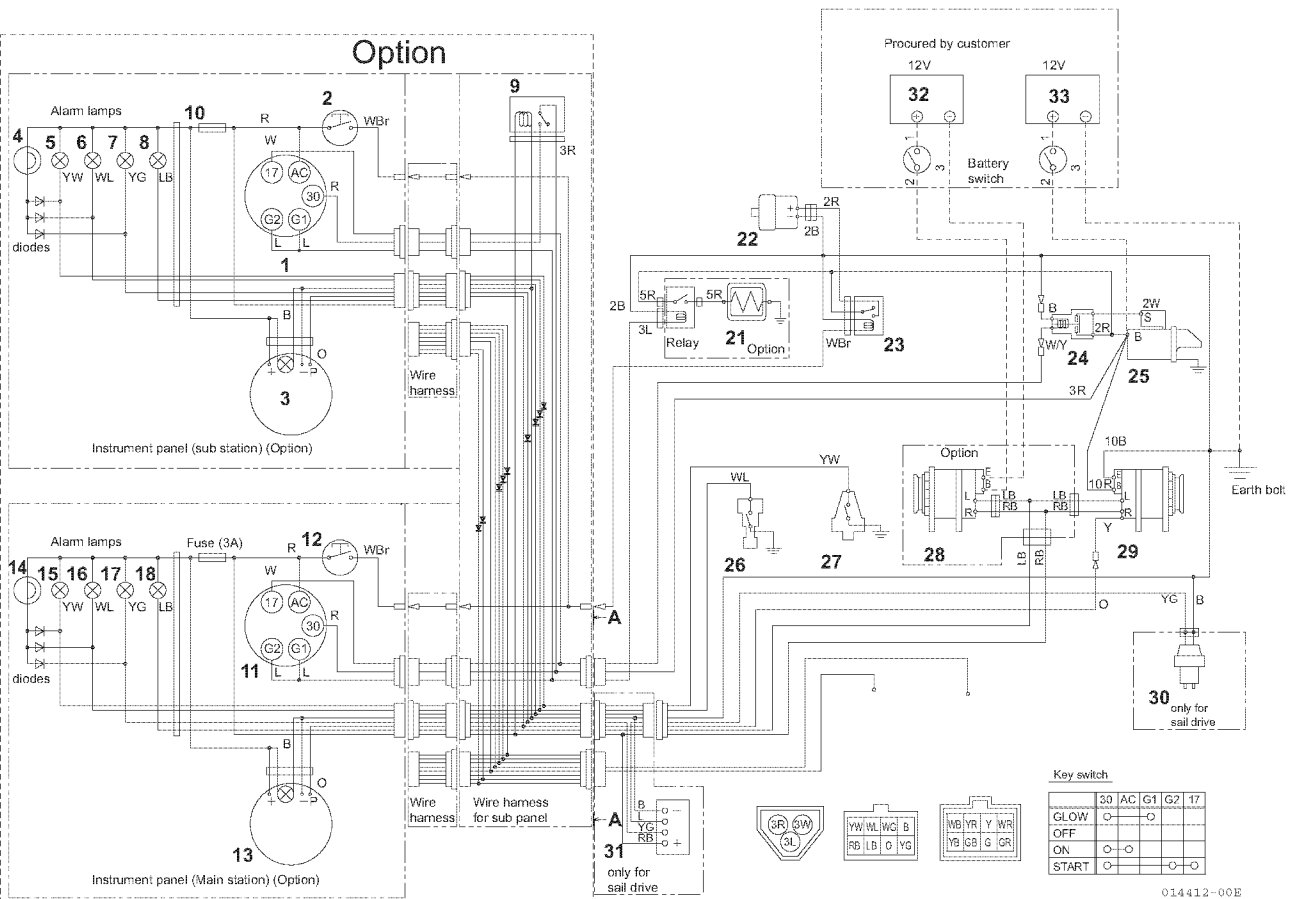

Figure 12-2

3JH4E - B-Type Instrument Panel

Color Coding	Description
R	Red
B	Black
W	White
L	Blue
RB	Red / Black
LB	Blue / Black
YW	Yellow / White
YB	Yellow / Black
YG	Yellow / Green
WL	White / Blue
WB	White / Black
WG	White / Green
GR	Green / Red
O	Orange
WBr	White / Brown

1	Starter Switch
2	Stop Switch
3	Tachometer / Hour Meter
4	Buzzer
5	Lubricating Oil Low Pressure Alarm
6	Coolant High Temperature Alarm
7	Water in Sail Drive Seal Alarm
8	Battery Low Charge Alarm
9	Relay (for 2 station - Optional)
10	Fuse (3A)
11	Starter Switch
12	Stop Switch
13	Tachometer / Hour Meter
14	Buzzer
15	Lubricating Oil Low Pressure Alarm
16	Coolant High Temperature Alarm
17	Water in Sail Drive Seal Alarm
18	Battery Low Charge Alarm
19	-
20	-
21	Air Heater (Optional)
22	Engine Stop Solenoid
23	Stop Relay
24	Starter Relay
25	Starter
26	Coolant High Temperature Switch
27	Lubricating Oil Low Pressure Switch
28	Alternator (Optional)
29	Alternator
30	Water in Sail Drive Seal Sensor (on Sail Drive)
31	Water in Sail Drive Seal Sensor Amplifier (Sail Drive Only)
32	Battery (Optional)
33	Battery
34	-
35	-

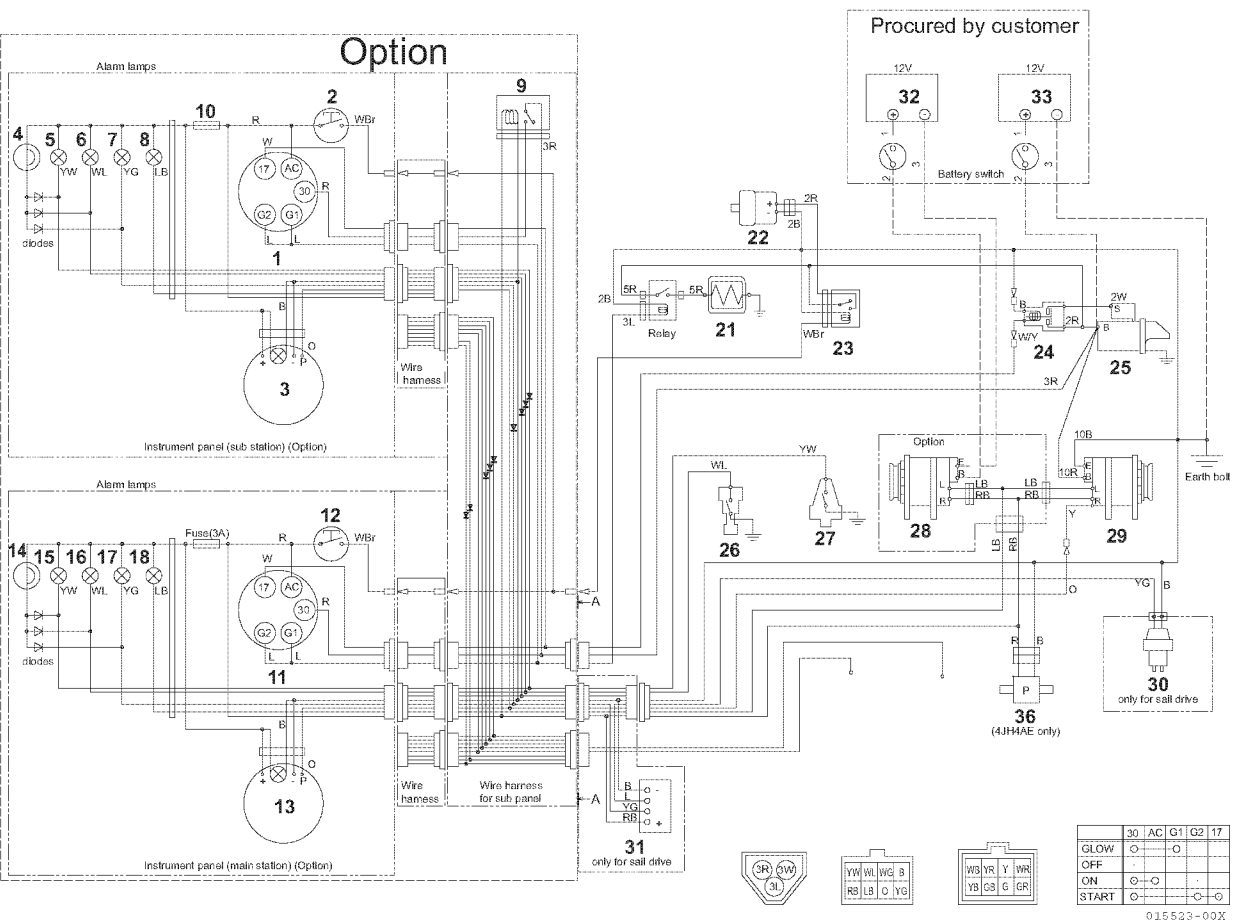

Figure 12-3

4JH4AE - B-Type Instrument Panel

Color Coding	Description
R	Red
B	Black
W	White
L	Blue
RB	Red / Black
LB	Blue / Black
YW	Yellow / White
YB	Yellow / Black
YG	Yellow / Green
WL	White / Blue
WB	White / Black
WG	White / Green
GR	Green / Red
O	Orange
WBr	White / Brown

1	Starter Switch
2	Stop Switch
3	Tachometer / Hour Meter
4	Buzzer
5	Lubricating Oil Low Pressure Alarm
6	Coolant High Temperature Alarm
7	Water in Sail Drive Seal Alarm
8	Battery Low Charge Alarm
9	Relay (for 2 station - Optional)
10	Fuse (3A)
11	Starter Switch
12	Stop Switch
13	Tachometer / Hour Meter
14	Buzzer
15	Lubricating Oil Low Pressure Alarm
16	Coolant High Temperature Alarm
17	Water in Sail Drive Seal Alarm
18	Battery Low Charge Alarm
19	-
20	-
21	Air Heater
22	Engine Stop Solenoid
23	Stop Relay
24	Starter Relay
25	Starter
26	Coolant High Temperature Switch
27	Lubricating Oil Low Pressure Switch
28	Alternator (Optional)
29	Alternator
30	Water in Sail Drive Seal Sensor (on Sail Drive)
31	Water in Sail Drive Seal Sensor Amplifier (Sail Drive Only)
32	Battery (Optional)
33	Battery
-	-
-	-
36	Fuel Feed Pump (4JH4AE Only)

4JH4-TE / 4JH4-HTE with Panel B x B Type

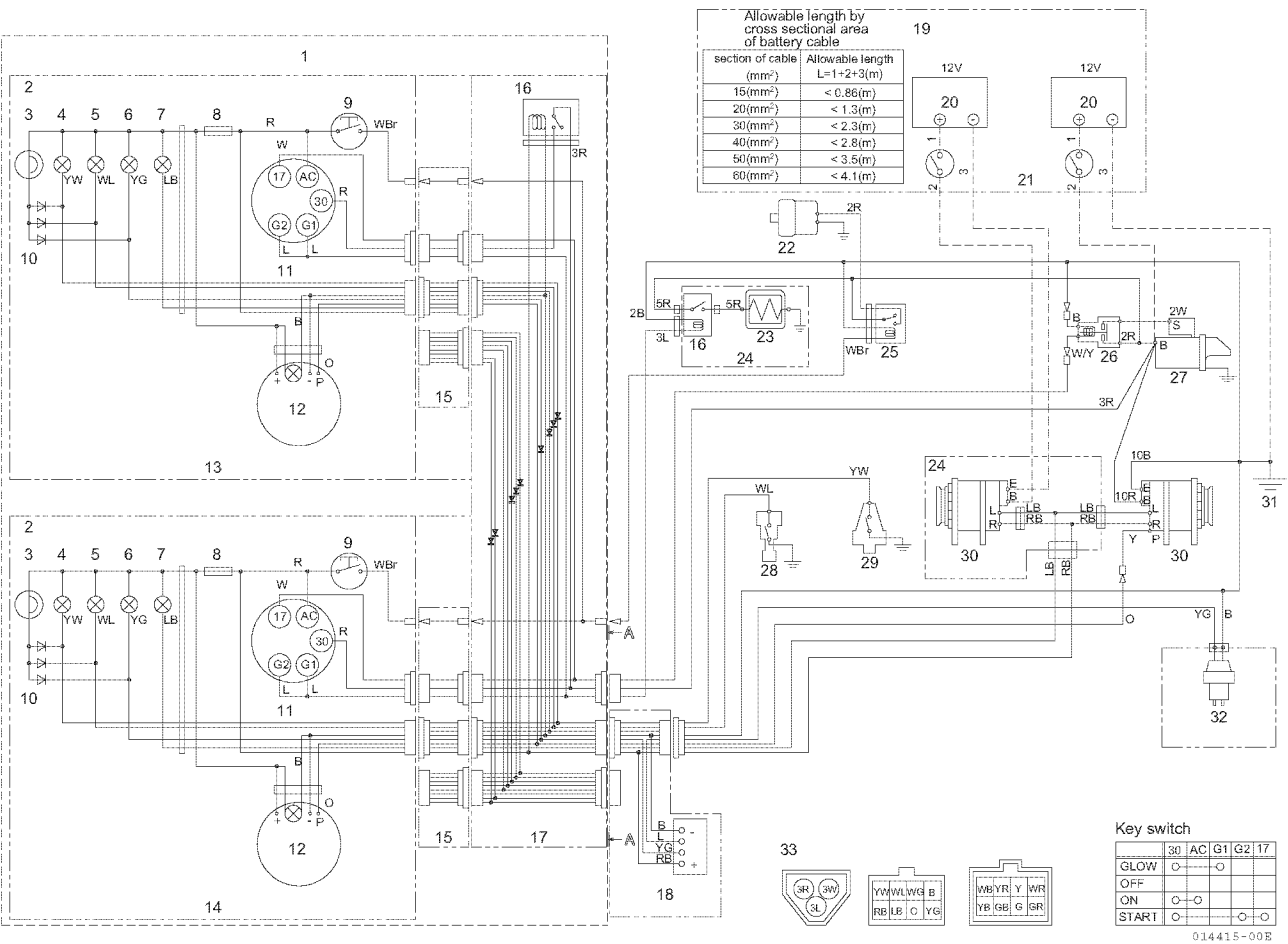

Figure 12-4

4JH4-TE / 4JH4-HTE with Panel B x B Type Instrument Panel

Color Coding		Engine Harness
R	Red	+
B	Black	-
W	White	Ignition
L	Blue	Air heater / grow (option)
RB	Red / Black	Alternator exciter
LB	Blue / Black	Alternator charge alarm
YW	Yellow / White	Engine oil pressure alarm
YB	Yellow / Black	Engine oil pressure
YG	Yellow / Green	Sail drive seal
WL	White / Blue	Water temperature alarm
WB	White / Black	Water temperature
WG	White / Green	Seawater flow alarm
GR	Green / Red	Fuel filter alarm
O	Orange	Pulse for tachometer
WBr	White / Brown	Electric stop

1	Option
2	Alarm Lamps
3	Buzzer
4	Oil Pressure
5	Coolant Temperature
6	Sail Drive Seal
7	Charge
8	Fuse (3A)
9	Stop Switch
10	Diodes
11	Key Switch
12	Tachometer / Hour Meter
13	Instrument Panel (Sub Station) (Option)
14	Instrument Panel (Main Station) (Option)
15	Wire Harness
16	Relay
17	Wire Harness for Sub Panel
18	Amplifier Only for Sail Drive
19	Procured by Customer
20	Battery
21	Battery Switch
22	Engine Stop Solenoid with VE Pump
23	Air Heater
24	Option
25	Stop Relay
26	Starter Relay
27	Starter
28	Coolant Temperature Switch
29	Engine Oil Pressure Switch
30	Alternator
31	Ground Bolt
32	Only for Sail Drive
33	Details of Coupler (View from A-A)

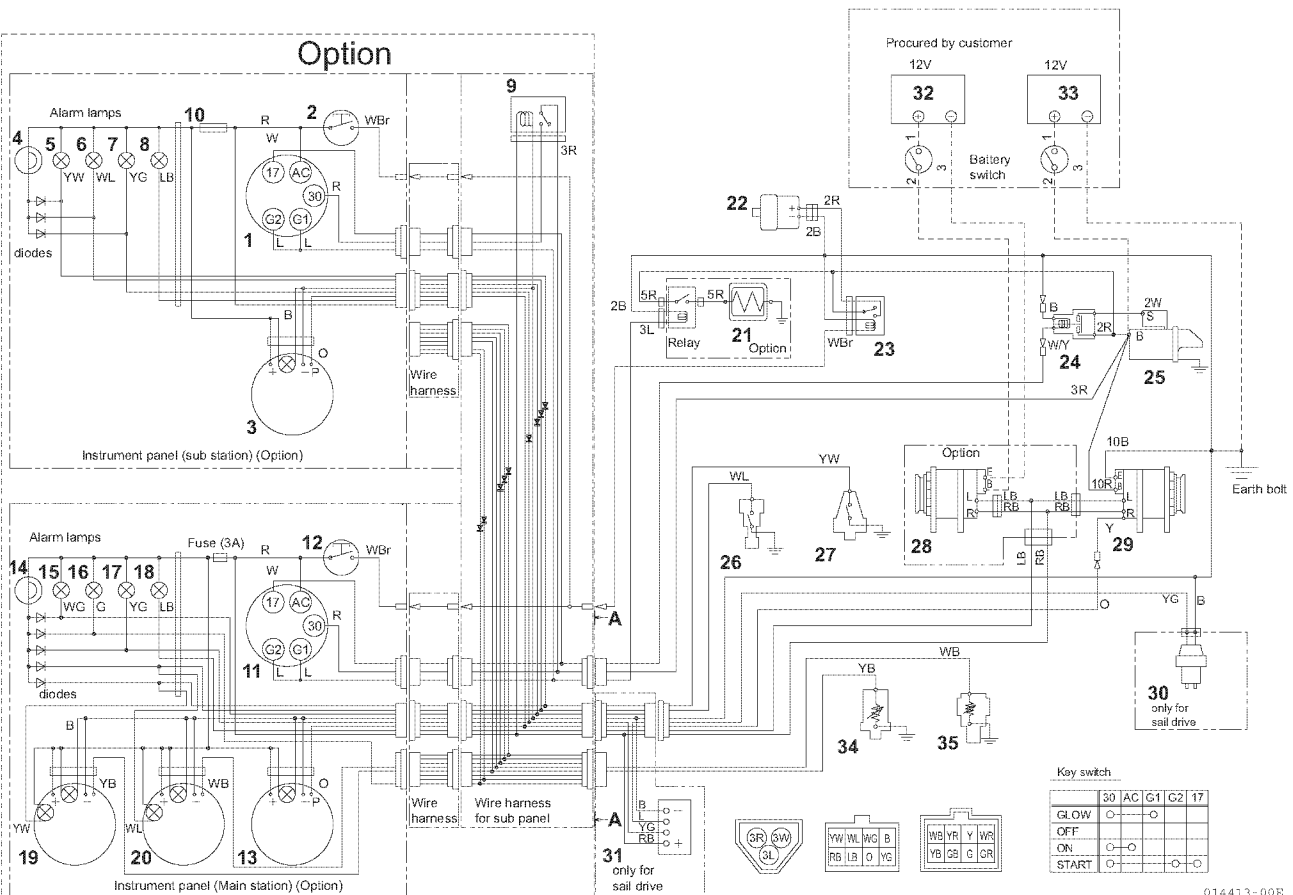

Figure 12-5

3JH4E - C-Type Instrument Panel

Color Coding	Description
R	Red
B	Black
W	White
L	Blue
RB	Red / Black
LB	Blue / Black
YW	Yellow / White
YB	Yellow / Black
YG	Yellow / Green
WL	White / Blue
WB	White / Black
WG	White / Green
GR	Green / Red
O	Orange
WBr	White / Brown

1	Starter Switch
2	Stop Switch
3	Tachometer / Hour Meter
4	Buzzer
5	Lubricating Oil Low Pressure Alarm
6	Coolant High Temperature Alarm
7	Water in Sail Drive Seal Alarm
8	Battery Low Charge Alarm
9	Relay (for 2 station - Optional)
10	Fuse (3A)
11	Starter Switch
12	Stop Switch
13	Tachometer / Hour Meter
14	Buzzer
15	Seawater Alarm
16	Fuel Filter
17	Water in Sail Drive Seal Alarm
18	Battery Low Charge Alarm
19	Oil Pressure Meter / Alarm
20	Coolant Temperature Meter / Alarm
21	Air Heater (Optional)
22	Engine Stop Solenoid
23	Stop Relay
24	Starter Relay
25	Starter
26	Coolant High Temperature Switch
27	Lubricating Oil Low Pressure Switch
28	Alternator (Optional)
29	Alternator
30	Water in Sail Drive Seal Sensor (on Sail Drive)
31	Water in Sail Drive Seal Sensor Amplifier (Sail Drive Only)
32	Battery (Optional)
33	Battery
34	Oil Pressure Sensor (Optional)
35	Coolant Temperature Sensor (Optional)

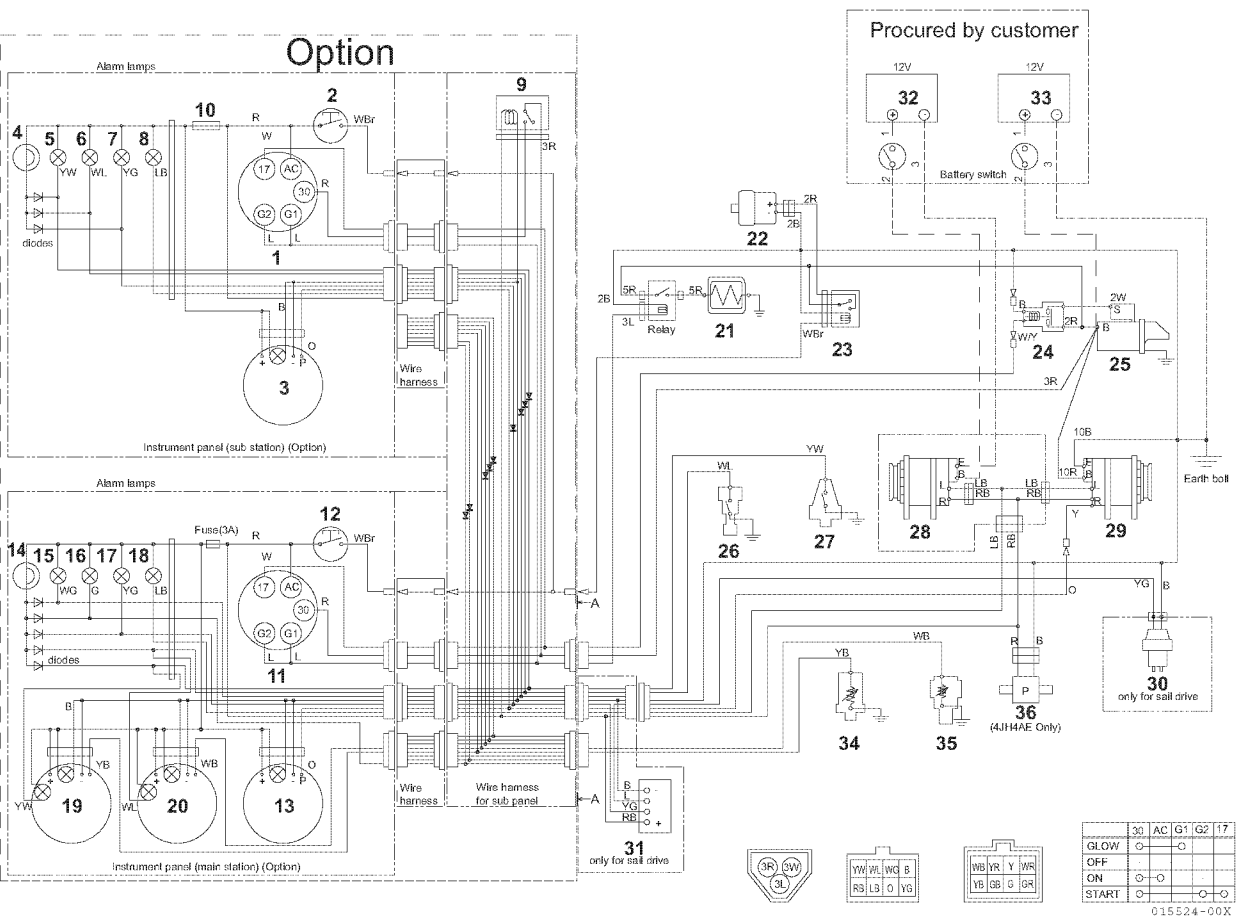

Figure 12-6

4JH4AE - C-Type Instrument Panel

Color Coding	Description
R	Red
B	Black
W	White
L	Blue
RB	Red / Black
LB	Blue / Black
YW	Yellow / White
YB	Yellow / Black
YG	Yellow / Green
WL	White / Blue
WB	White / Black
WG	White / Green
GR	Green / Red
O	Orange
WBr	White / Brown

1	Starter Switch
2	Stop Switch
3	Tachometer / Hour Meter
4	Buzzer
5	Lubricating Oil Low Pressure Alarm
6	Coolant High Temperature Alarm
7	Water in Sail Drive Seal Alarm
8	Battery Low Charge Alarm
9	Relay (for 2 Station - Optional)
10	Fuse (3A)
11	Starter Switch
12	Stop Switch
13	Tachometer / Hour Meter
14	Buzzer
15	Seawater Alarm
16	Fuel Filter
17	Water in Sail Drive Seal Alarm
18	Battery Low Charge Alarm
19	Oil Pressure Meter / Alarm
20	Coolant Temperature Meter / Alarm
21	Air Heater
22	Engine Stop Solenoid
23	Stop Relay
24	Starter Relay
25	Starter
26	Coolant High Temperature Switch
27	Lubricating Oil Low Pressure Switch
28	Alternator (Optional)
29	Alternator
30	Water in Sail Drive Seal Sensor (on Sail Drive)
31	Water in Sail Drive Seal Sensor Amplifier (Sail Drive Only)
32	Battery (Optional)
33	Battery
34	Oil Pressure Sensor
35	Coolant Temperature Sensor
36	Fuel Feed Pump (4JH4AE Only)

4JH4-TE / 4JH4-HTE with Panel C x B Type

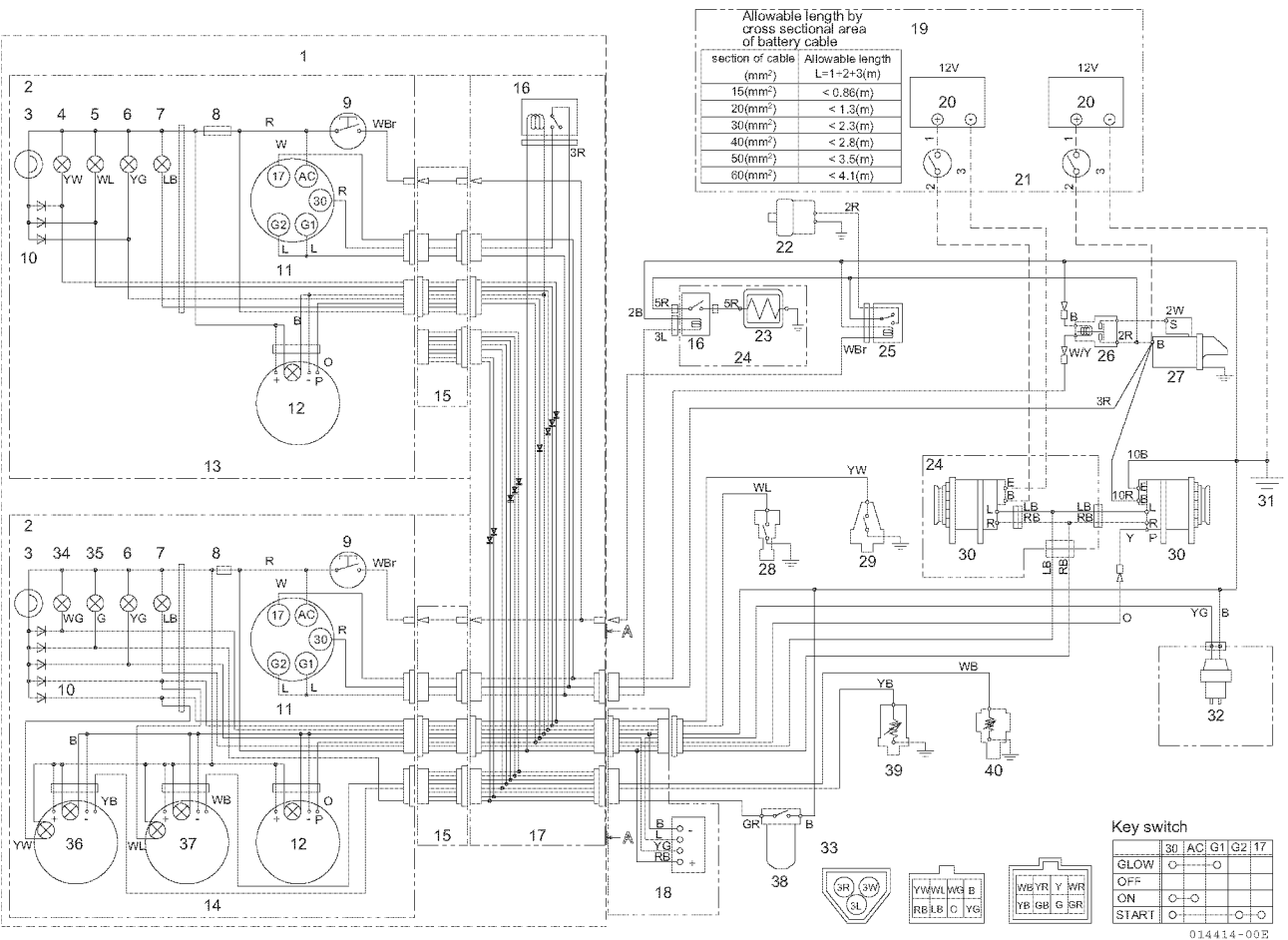

Figure 12-7

4JH4-TE / 4JH4-HTE with Panel C x B Type Instrument Panel

Color Coding		Engine Harness
R	Red	+
B	Black	-
W	White	Ignition
L	Blue	Air heater / glow (option)
RB	Red / Black	Alternator exciter
LB	Blue / Black	Alternator charge alarm
YW	Yellow / White	Engine oil pressure alarm
YB	Yellow / Black	Engine oil pressure
YG	Yellow / Green	Sail drive seal
WL	White / Blue	Water temperature alarm
WB	White / Black	Water temperature
WG	White / Green	Seawater flow alarm
GR	Green / Red	Fuel filter alarm
O	Orange	Pulse for tachometer
WBr	White / Brown	Electric stop

1	Option
2	Alarm Lamps
3	Buzzer
4	Oil Pressure
5	Coolant Temperature
6	Sail Drive Seal
7	Charge
8	Fuse (3A)
9	Stop Switch
10	Diodes
11	Key Switch
12	Tachometer / Hour Meter
13	Instrument Panel (Sub Station) (Option)
14	Instrument Panel (Main Station) (Option)
15	Wire Harness
16	Relay
17	Wire Harness for Sub Panel
18	Amplifier Only for Sail Drive
19	Procured by Customer
20	Battery
21	Battery Switch
22	Engine Stop Solenoid with VE Pump
23	Air Heater
24	Option
25	Stop Relay
26	Starter Relay
27	Starter
28	Coolant Temperature Switch
29	Engine Oil Pressure Switch
30	Alternator
31	Ground Bolt
32	Only for Sail Drive
33	Details of Coupler (View from A-A)
34	Seawater Alarm
35	Fuel Filter
36	Oil Pressure Meter / Alarm
37	Water Temperature Meter / Alarm
38	Fuel Filter Switch
39	Oil Pressure Sender
40	Coolant Temperature Sender

INSTRUMENT PANEL

B-Type Instrument Panel (Selectable Optional)

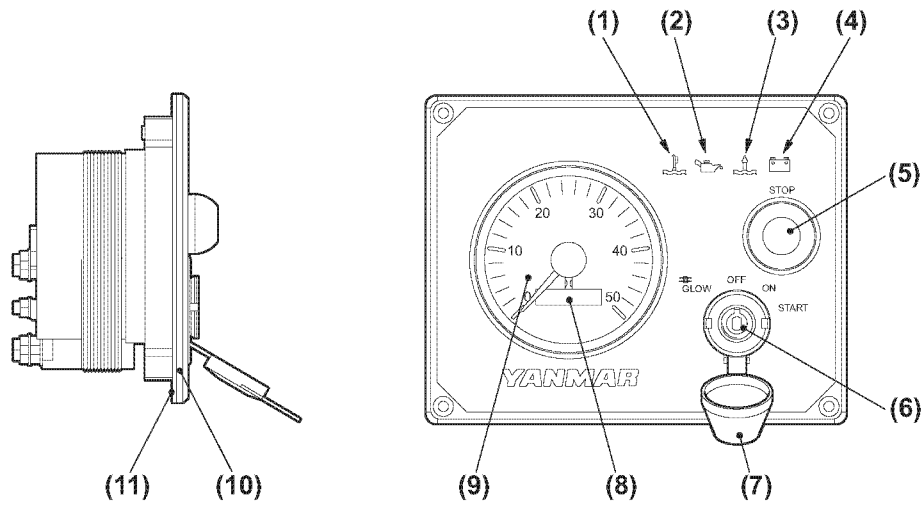

011073-00X

Figure 12-8

- 1 – Coolant High Temperature Alarm
- 2 – Lubricating Oil Low Pressure Alarm
- 3 – Water In Sail Drive Seal Alarm
- 4 – Battery Low Charge Alarm
- 5 – Stop Button Switch
- 6 – Key Switch

- 7 – Moisture Cap For Key Switch
- 8 – Hour Meter
- 9 – Tachometer
- 10 – Panel With Cover Foil
- 11 – Rubber Seal, B Panel

C-Type Instrument Panel (Selectable Optional)

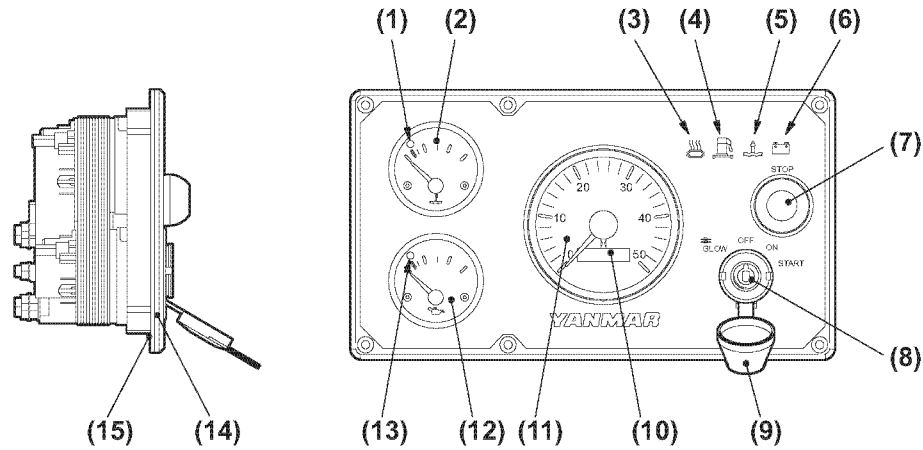

011074-00X

Figure 12-9

- 1 – Coolant High Temperature Alarm
- 2 – Coolant Temperature Meter
- 3 – Seawater Insufficient Flow Alarm
- 4 – Water In Fuel Filter Alarm
- 5 – Water In Sail Drive Seal Alarm
- 6 – Battery Low Charge Alarm
- 7 – Stop Button Switch
- 8 – Key Switch

- 9 – Moisture Cap For Key Switch
- 10 – Hour Meter
- 11 – Tachometer
- 12 – Lubricating Oil Pressure Meter
- 13 – Lubricating Oil Low Pressure Alarm
- 14 – Panel With Cover Foil
- 15 – Rubber Seal, C Panel

FUNCTION DESCRIPTION - WARNING DEVICES

Oil Pressure Alarm

Oil Pressure Alarm Circuit

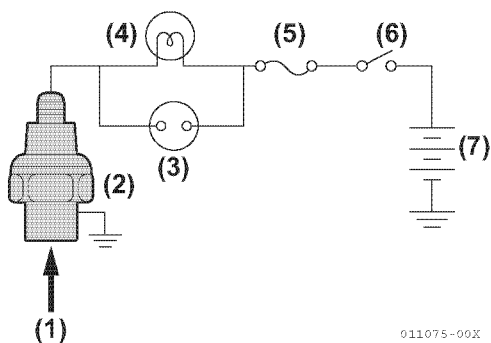

Figure 12-10

- 1 – Oil Pressure
- 2 – Oil Pressure Switch
- 3 – Alarm Buzzer
- 4 – Pilot Lamp
- 5 – Fuse
- 6 – Main Switch
- 7 – Battery

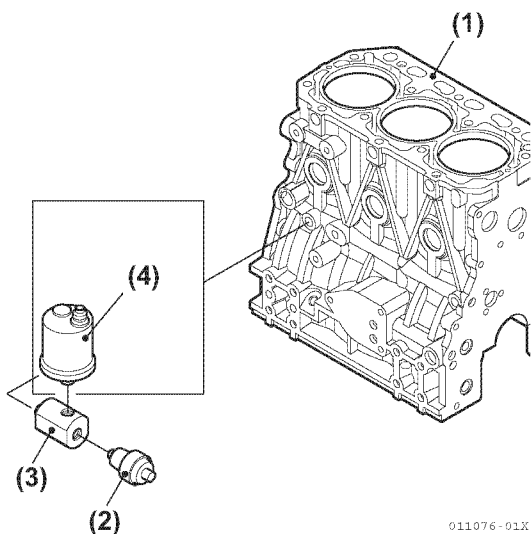

Figure 12-11

- 1 – Cylinder Block
- 2 – Oil Pressure Switch
- 3 – Damper
- 4 – Oil Pressure Sender (Optional)

Oil Pressure Switch Structure

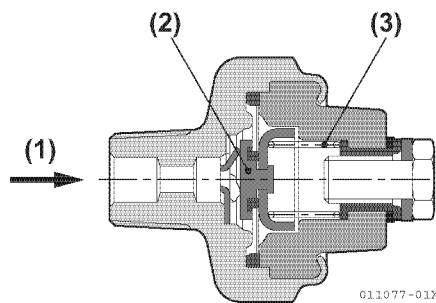

Figure 12-12

- 1 – Oil Pressure
- 2 – Contacts
- 3 – Spring

If the lubricating oil pressure is below 0.01-0.03 MPa (0.1-0.3 kgf/cm², 1.42-4.26 lb/in.² (1.42-4.26 psi)), with the main switch in the ON position, the contacts of the oil pressure switch are closed by a spring and the lamp is illuminated through the lamp / oil pressure switch / ground circuit system. If the oil pressure is normal, the switch contacts are opened by the lubricating oil pressure and the lamp remains off.

Inspection

Problem	Inspection Item	Inspection Method	Corrective Action
Lamp not illuminated when main switch set to ON.	Oil pressure lamp blown out.	1) Visual inspection. 2) Lamp not illuminated even when main switch set to ON position and terminals of oil pressure switch grounded.	Replace lamp.
	Operation of oil pressure switch.	Lamp illuminated when checked as described in 2) above.	Replace oil pressure switch.
Lamp not extinguished while engine running.	Oil level low.	Stop engine and check oil level with dipstick.	Add oil.
	Oil pressure low.	Measure oil pressure.	Repair bearing wear and adjust regulator valve.
	Oil pressure faulty.	Switch faulty if abnormal at 1) and 2) above.	Replace oil pressure switch.
	Wiring between lamp and oil pressure switch faulty.	Cut the wiring between the lamp and switch and wire with separate wire.	Repair wiring harness.

Sending Unit for Lubricating Oil Pressure Gauge

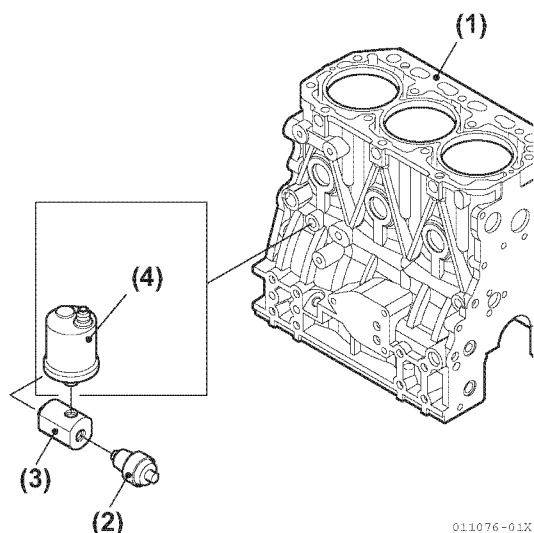

The sending unit for the lubricating oil pressure gauge has a mounting seat for mounting on the lubricating oil filter bracket. Oil pressure is measured when the oil enters into the main gallery after being fed from the lubricating oil cooler and passing through the oil pressure control valve. Always install a damper when installing the oil pressure sender unit.

Lubricating Oil Pressure Sender Unit

Part Code No.	119773-91650
Type	Resistance switch
Rated Voltage	DC 12V
Maximum Operating Pressure	0.98 MPa (10 kgf/cm ² [142 psi])

Figure 12-13

- 1 – Cylinder Block
- 2 – Oil Pressure Switch
- 3 – Damper
- 4 – Oil Pressure Sender (Optional)

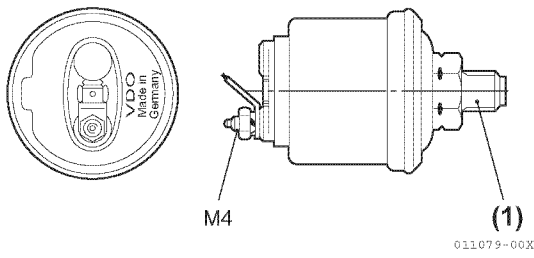

Figure 12-14

1 – ISO R1/8 Taper

Coolant Temperature Alarm

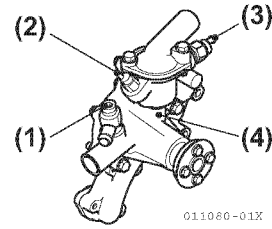

Figure 12-15

- 1 – Inlet for Water Heater
- 2 – Water Temperature Heater
- 3 – Water Temperature Switch
- 4 – Freshwater Pump

Water Temperature Alarm Circuit

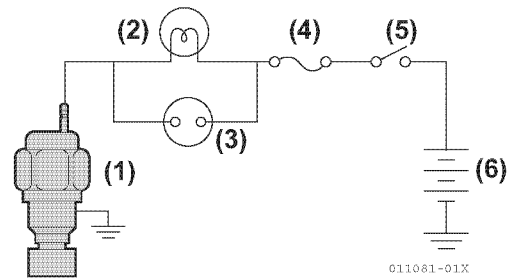

Figure 12-16

- 1 – Water Temperature Unit
- 2 – Pilot Lamp
- 3 – Alarm Buzzer
- 4 – Fuse
- 5 – Main Switch
- 6 – Battery

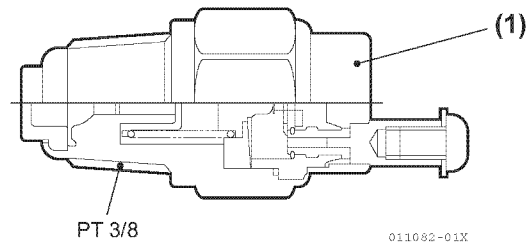

Figure 12-17

1 – Green Colored

A water temperature lamp and water temperature gauge, backed up by an alarm in the instrument panel, are used to monitor the temperature of the engine coolant. A high thermal expansion material is set on the end of the water temperature unit. When the coolant temperature reaches a specified high temperature, the contacts are closed, and an alarm lamp and buzzer are activated at the instrument panel.

Operating Temperature	ON	97-103 deg. C
Electric Capacity		DC 12V, 1A
Response Time		within 60 sec.
Indication Color		Black
Tightening Torque		23.5-31.4 N·m (2.40-3.20 kgf-m [17.3-23.2 lb-ft])

Sending Unit for the Coolant Temperature Gauge

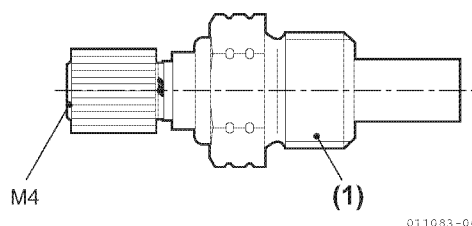

Figure 12-18

1 – ISO R3/8 Taper

The water temperature sending unit has a mounting seat for mounting on the freshwater pump unit. Water temperature is measured when the coolant flows into the thermostat housing after leaving the cylinder head.

Part Code No.	119773-91700
Type	Thermistor switch
Rated Voltage	12V

Air Heater (Standard for 4JH4AE, 4JH4-TE and 4JH4-HTE. Optional for 3JH4E)

4JH4-TE and 4JH4-HTE

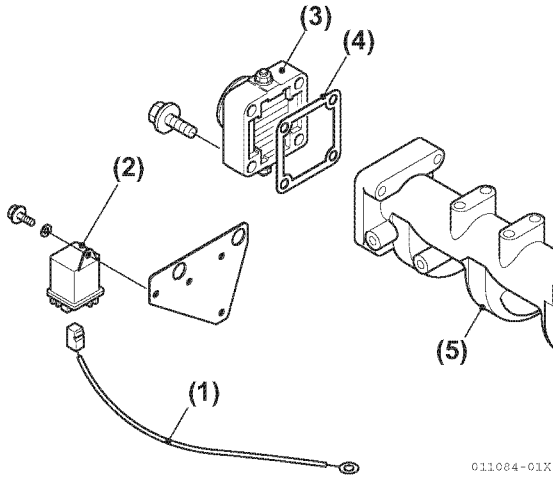

Figure 12-19

- 1 – Wire Harness
- 2 – Relay
- 3 – Air Heater
- 4 – Gasket
- 5 – Intake Manifold

3JH4E and 4JH4AE

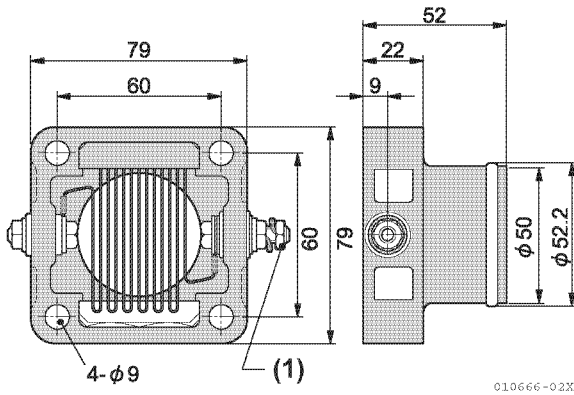

Figure 12-20

- 1 – 2-M6 x 1 Terminal

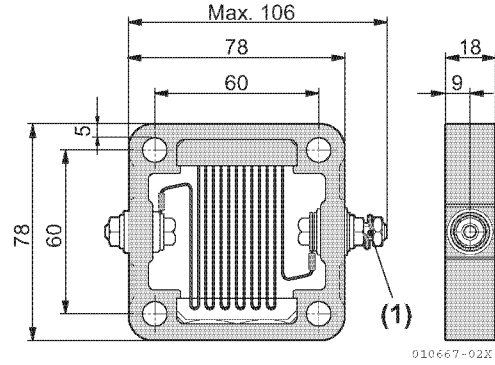

Figure 12-21

- 1 – 2-M6 x 1 Terminal

An air heater is available for warming intake air when starting in a cold weather. The air heater is mounted to the intake manifold. The device is operated by the glow switch on the instrument panel.

	3JH4E/4JH4AE	4JH4-TE/4JH4-HTE
Part No.	129120-77502	129100-77501
Rated Output	390W (1332 BTU/hour)	
Rated Current	35.5A	
Rated Voltage	DC11V	

Electric Engine Stop Solenoid

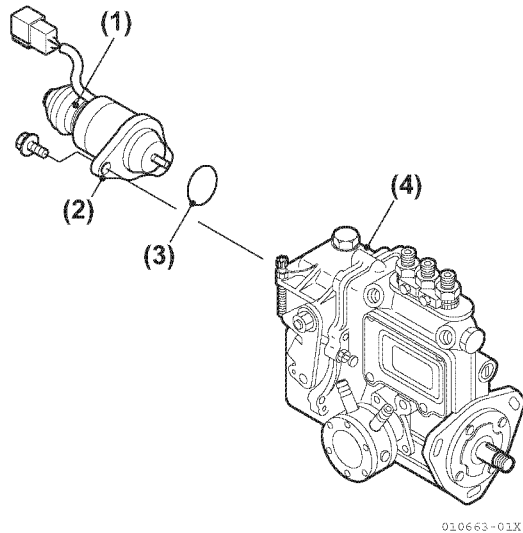

Figure 12-22

- 1 – Emergency Stop Button**
- 2 – Stop Solenoid**
- 3 – O-Ring**
- 4 – Governor**

The electric engine stop device is fitted to the governor. The device is operated by the stop switch on the instrument panel.

Electric Emergency Stop (for 3JH4E and 4JH4AE)

The emergency stop button is integrated with the solenoid. When the stop button is pushed, the engine will shut down.

This Page Intentionally Left Blank

Section 13

TROUBLESHOOTING

	Page
Safety Precautions	13-3
Introduction.....	13-3
Troubleshooting Chart.....	13-4
Starting Trouble.....	13-4
Exhaust Color.....	13-5
Vibration - Drive Disengaged.....	13-6
Vibration - Drive Engaged	13-6
Engine Knocks.....	13-7
Low Power Output.....	13-7
Engine Overheat.....	13-8
Engine Runs Cold.....	13-8
Coolant Loss.....	13-9
Lubricating Oil Pressure Low.....	13-9
Panel Display.....	13-9
Troubleshooting by Measuring Compression Pressure	13-10
After Troubleshooting or Repair	13-12

This Page Intentionally Left Blank

SAFETY PRECAUTIONS

Before you troubleshoot, read the following safety information and review the *Safety Section on page 2-1*.

INTRODUCTION

This section of the *Service Manual* contains information and troubleshooting charts to accurately assess engine, starter or alternator problems.

TROUBLESHOOTING CHART

Starting Trouble

Problem / Symptom	Cause	Action	Reference
Engine Will Not Crank	Discharged battery	Charge / replace battery	See OEM Information
	Blown fuse	Replace fuse	See <i>Wiring Diagram</i> on page 12-6
	Defective starter motor	Replace starter motor	See <i>Starter Motor Service</i> on page 10-6
	Loose wiring connections	Tighten connections	See <i>Wiring Diagram</i> on page 12-6
	Faulty connection in starting switch	Repair using sandpaper or replace	See <i>Instrument Panel</i> on page 12-18
	Rough cap movement	Repair using sandpaper and then grease	See <i>Starter Motor Service</i> on page 10-6
	Edges of gear teeth misshapen	Adjust	See <i>Starter Motor Service</i> on page 10-6
	Piston ring sticks	Disassemble and repair or replace	See <i>Tests and Adjustments</i> on page 5-28
Engine Cranks but Will Not Start	No fuel to engine	Check fuel level in tank	See OEM Information
		Ensure all valves are on	See OEM Information
		Check fuel supply pump	See <i>MP Fuel Injection Pump System</i> on page 6-41
	No fuel to cylinders	Clean or replace clogged pre-filter (if equipped)	See <i>Fuel Line Replacement Filter</i> on page 6-36
		Clean or replace fuel filter / water separator	See <i>Fuel / Water Separator Replacement</i> on page 6-38
		Replace clogged fine filter	See <i>Fuel Line Replacement Filter</i> on page 6-36
		Bleed fuel system	See <i>Bleeding the Fuel System</i> on page 6-40
		Check fuel injection pump and replace if necessary	See <i>MP Fuel Injection Pump System</i> on page 6-41
		Check fuel injection nozzle and replace if necessary	See <i>Fuel Injectors</i> on page 6-63
		Check fuel injection pipes and replace if necessary	See <i>Fuel System Components</i> on page 6-48
	Water in fuel tank	Drain water from fuel tank	See OEM Information
	Leakage pressurized air	Check cylinder gasket and bolt or suction/exhaust valves and piston ring. Replace if necessary	See <i>Test Compression</i> on page 5-28
	Governor handle is in STOP position	Move governor handle to acceleration position	See <i>Governor</i> on page 6-27
	Low ambient temperature	Install optional glow plug control	NA
		Install block heater	NA
Oil viscosity too high	Replace with correct viscosity oil for operating conditions	See <i>Engine Oil Specifications</i> on page 3-43	

Exhaust Color

Problem / Symptom	Cause	Action	Reference
White Smoke	Cold engine	Allow engine to warm to operating temperature	NA
		Defective thermostat, replace	<i>See Remove and Install Thermostat on page 7-21</i>
	Incorrect fuel	Replace fuel with correct type	<i>See Diesel Fuel Specifications on page 3-39</i>
	Incorrect fuel injection nozzle	Test / replace fuel injection nozzle	<i>See Fuel Injectors on page 6-63</i>
	Injection timing is incorrect	Adjust	<i>See Adjust Fuel Injection Timing on page 6-23</i>
White Smoke with Water Vapor	Leaking cylinder head gasket	Repair	<i>See Test Compression on page 5-28</i>
	Leaking charge intercooler	Repair as necessary	<i>See Disassembly on page 5-29</i>
	Cracked cylinder head		
	Cracked cylinder		
Blue Smoke	Worn piston rings / cylinders	Repair as necessary	<i>See Disassembly on page 5-29</i>
	Oil leak in turbocharger (oil present in intake manifold)		
Black Smoke Under Load	Clogged air filter	Clean / replace air filter	<i>See Clean Air Cleaner on page 9-6</i>
	Incorrect valve timing	Check / correct camshaft installation	<i>See Valve Clearance Adjustment on page 5-61</i>
	Low injection pressure	Adjust fuel injection nozzle	<i>See Fuel Injectors on page 6-63</i>
	Defective (leaking) fuel injection nozzle	Test / replace fuel injection nozzle	<i>See Fuel Injectors on page 6-63</i>
	Low charge air pressure	Clean or replace	<i>See Turbocharger Service on page 9-6</i>
		Damaged turbocharger. Repair or replace	<i>See Turbocharger Service on page 9-6</i>
	Excessive exhaust backpressure	Correct as necessary	NA
	Excessive intake suction loss	Correct as necessary	NA
	Over loading	Reduce load	NA

Vibration - Drive Disengaged

Problem / Symptom	Cause	Action	Reference
Rough at All Engine Speeds	Air in fuel system	Bleed fuel system	<i>See Bleeding the Fuel System on page 6-40</i>
	Faulty fuel injector	Replace as necessary	<i>See Fuel Injectors on page 6-63</i>
	Leaking cylinder head gasket	Replace	<i>See Test Compression on page 5-28</i>
	Damaged intake or exhaust valves	Repair / replace as necessary	<i>See Test Compression on page 5-28</i>
	Damaged turbocharger	Replace	<i>See Turbocharger Service on page 9-6</i>
	Incorrect injection pressure	Check / replace fuel injection nozzle	
Check / replace fuel injection pump			<i>See MP Fuel Injection Pump System on page 6-41</i>
Vibration Increases with Engine Speed (Sail Drive Models)	Worn or damaged spline shaft	Replace as necessary	<i>See Assembly on page 5-84</i>
Vibration Increases with Engine Speed	Loose parts	Tighten loose parts	NA

Vibration - Drive Engaged

Problem / Symptom	Cause	Action	Reference
Rough at All Speeds	Engine and propeller shaft misaligned	Check and adjust	<i>See Principal Engine Specifications on page 3-45</i>
	Damaged bearing	Replace	<i>Main Bearing on page 5-75</i>
	Excessive backlash of gear	Repair / replace	<i>See Gear Inspection on page 5-80</i>
	Leaking cylinder head gasket	Replace	<i>See Test Compression on page 5-28</i>
	Bent propeller shaft	Replace as necessary	<i>Main Bearing on page 5-75</i>
Rough at Higher Speeds	Bent propeller	Replace as necessary	See OEM Information
	Slipping clutch / clutch dog	Repair as necessary	<i>Damper Disk and Cooling Fan on page 5-82</i>
	Incorrect injection pressure	Check / replace fuel injection nozzle	
Check / replace fuel injection pump			<i>Fuel System Service on page 6-14</i>

Engine Knocks

Problem / Symptom	Cause	Action	Reference
Excess Fuel Injected	Defective fuel injection nozzle	Check / replace fuel injection nozzle	<i>Fuel System Service on page 6-14</i>
	High fuel injection pressure	Check / replace fuel injection pump	<i>Fuel System Service on page 6-14</i>
Noise Changes with Engine Load	Incorrect or poor quality fuel	Drain and refill tank	<i>Fuel System Service on page 6-14</i>
	Worn crankshaft / bearings	Repair / replace as necessary	<i>Main Bearing on page 5-75</i>
	Broken piston / rings	Repair / replace as necessary	<i>See Tests and Adjustments on page 5-28</i>

Low Power Output

Problem / Symptom	Cause	Action	Reference
Miscellaneous	Clogged intake air filter	Clean / replace	<i>See Clean Air Cleaner on page 9-6</i>
	Leaking cylinder head gasket	Replace	<i>See Tests and Adjustments on page 5-28</i>
	Damaged turbocharger	Replace	<i>Turbocharger Service on page 9-6</i>
	Seizure of moving parts	Disassemble, check and repair	<i>Turbocharger Service on page 9-6</i>
	Incorrect propeller	Replace	See OEM Information
	Excessive exhaust backpressure	Remove obstruction	NA
Fuel	Plugged fuel filter(s)	Clean / replace as necessary	<i>Fuel Injection Line Installation on page 6-17</i>
	Faulty fuel feed pump	Replace	<i>Fuel Feed Pump Replacement on page 6-17</i>
	Incorrect fuel quality	Replace with correct fuel	<i>Diesel Fuel Specifications on page 3-39</i>
Low Fuel Injection Pressure	Defective fuel injection nozzle	Check / replace	<i>See Fuel Injectors on page 6-63</i>
	Worn fuel injection pump	Check / replace	<i>See MP Fuel Injection Pump System on page 6-41</i>
	Injection timing is incorrect	Adjust	<i>See Adjust Fuel Injection Timing on page 6-23</i>
Coolant	Insufficient coolant	Check / replace coolant pump	<i>Engine Coolant on page 3-44</i>
Lubricating Oil Supply	Insufficient lubricating oil supply	Check / replace lubricating oil pump or lubricating oil level	<i>See Engine Oil Specifications on page 3-43</i>
Governor	Damaged bearing	Replace	<i>Main Bearing on page 5-75</i>
	Governor link length incorrect	Repair	See OEM Information

Problem / Symptom	Cause	Action	Reference
Low RPM at Wide Open Throttle	Propeller pitch too great	Replace	See OEM Information
	Engine overheated	Reduce load / repair cooling system	<i>Tests and Adjustments on page 7-8</i>
	Damaged turbocharger	Replace	<i>Turbocharger Service on page 9-6</i>

Engine Overheat

Problem / Symptom	Cause	Action	Reference
Instrument Shows High Temperature	Clogged seawater inlet	Clean	NA
	Low coolant level	Fill with coolant / inspect for leak	<i>Engine Coolant on page 3-44</i>
	Clogged seawater filter (if equipped)	Clean	NA
	Clogged heat exchanger	Clean	<i>Remove and Install Heat Exchanger on page 7-16</i>
	Seawater pump worn or damaged	Repair / replace as necessary	<i>Seawater Pump on page 7-22</i>
	Defective sensor / instrument	Repair as necessary	<i>Sensor and Switch Locations on page 12-4</i>
	Defective thermostat	Replace	<i>Test Thermostat on page 7-9</i>
	Damaged closed coolant pump	Replace	<i>Remove and Install Coolant Pump on page 7-19</i>
	Combustion gas leakage (causes loss of coolant)	Repair as necessary	<i>See Test Compression on page 5-28</i>
	Coolant water pump belt slips or pump pulley loose on pump shaft	Repair as necessary	<i>Replace Coolant Pump Belt and Pulley on page 7-23</i>
	Faulty lubricating oil pump	Check and repair / replace	<i>Engine Oil Pump on page 8-11</i>
Over loading	Reduce load	NA	

Engine Runs Cold

Problem / Symptom	Cause	Action	Reference
Instrument Shows Low Temperature	Defective sensor / instrument	Repair / replace as necessary	<i>Sensor and Switch Locations on page 12-4</i>
	Defective thermostat	Replace	<i>Test Thermostat on page 7-9</i>

Coolant Loss

Problem / Symptom	Cause	Action	Reference
Repeated Low Coolant Level	Defective cylinder head gasket (external leakage)	Replace	<i>See Test Compression on page 5-28</i>
	External leakage at connection	Repair as necessary	<i>Pressure Testing Cooling System and Filler Cap on page 7-8</i>
Coolant Forced Out of Coolant Recovery Tank	Turbocharger pressure enters cooling system via leaking charge intercooler	Repair / replace as necessary	<i>Coolant Recovery Tank on page 7-25</i>
White Smoke when Engine is Hot	Crack in cylinder head	Repair / replace as necessary	<i>See Test Compression on page 5-28</i>
	Leaking cylinder head gasket	Replace	<i>See Test Compression on page 5-28</i>

Lubricating Oil Pressure Low

Problem / Symptom	Cause	Action	Reference
Insufficient Lubricating Oil Supply	Clogged lubricating oil filter	Clean or replace filter element	<i>Change Engine Oil, Replace Engine Oil Filter Element and Clean Engine Oil Cooler on page 8-9</i>
	Damaged lubricating oil pump	Repair / replace as necessary	<i>Engine Oil Pump on page 8-11</i>
	Loose pressure adjustment valve	Tighten adjustment valve	<i>Engine Oil Pump on page 8-11</i>
	Oil leakage from pump safety valve	Tighten safety valve	<i>Engine Oil Pump on page 8-11</i>
	Inadequate viscosity of lubricating oil	Change lubricating oil	<i>See Engine Oil Specifications on page 3-43</i>
	Insufficient amount of lubricating oil	Add lubricating oil	<i>See Engine Oil Specifications on page 3-43</i>
Instrument Faulty	Faulty pressure gauge	Replace	<i>Check Engine Oil Pressure on page 8-6</i>
	Faulty pressure sensor or connector	Check / replace	<i>Check Engine Oil Pressure on page 8-6</i>

Panel Display

Problem / Symptom	Cause	Action	References
No Display	Harness connector loose	Repair as necessary	<i>Sensor and Switch Locations on page 12-4</i>
	Defective fuse	Replace	<i>See Wiring Diagram on page 12-6</i>

TROUBLESHOOTING BY MEASURING COMPRESSION PRESSURE

Compression pressure drop is one of the major causes of increasing blow-by gas (lubricating oil contamination or increased lubricating oil consumption) or starting failure. The compression pressure is affected by the following factors:

- Degree of clearance between piston and cylinder
- Degree of clearance at intake / exhaust valve seat
- Gas leak from nozzle gasket or cylinder head gasket

The pressure drops because of increased parts wear and reduced durability resulting from long engine use.

A pressure drop may also be caused by scratched cylinder or piston. The cylinder and piston may have been damaged because an air cleaner element is dirty or a piston ring is worn or broken.

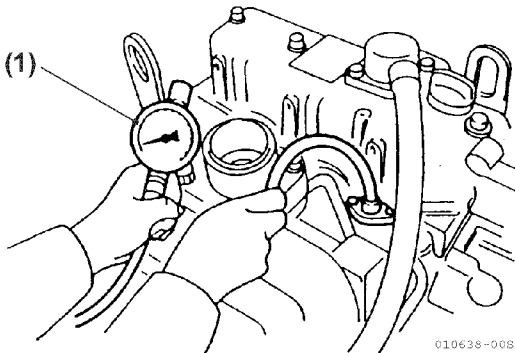

Figure 13-1

1 – Compression Gauge

- Compression pressure measurement method
 1. After warming up the engine, remove the fuel injection pipe and valves from the cylinder to be measured.
 2. Crank the engine before installing the compression gauge adapter.

- (a) Perform cranking with the stop handle at the STOP position (no injection state).
 - (b) *See Test Compression on page 5-28* for the compression gauge and compression gauge adapter.
3. Install the compression gauge and compression gauge adapter at the cylinder to be measured.
 - (a) ALWAYS install a gasket at the tip end of the adapter.
 4. With the engine set to the same state as in 2.(a), crank the engine with the starter motor until the compression gauge reading is stabilized.

- Standard compression pressure

Engine Compression Pressure List (Reference Value)

Model	Compression Pressure at 250 minimum ⁻¹ (rpm)	Deviation Among Cylinders MPa (kgf/cm ²)
	Standard	
3JH4E, 4JH4AE and 4JH4-TE	3.4 ± 0.1 MPa, 35 ± 1 kgf/cm ² (493 ± 14 psi)	0.2 to 0.3 MPa, 2 to 3 kgf/cm ² (29 to 44 psi)
4JH4-HTE	3.2 ± 0.1 MPa, 32 ± 1 kgf/cm ² (464 ± 14 psi)	

- Engine speed and compression pressure (for reference)

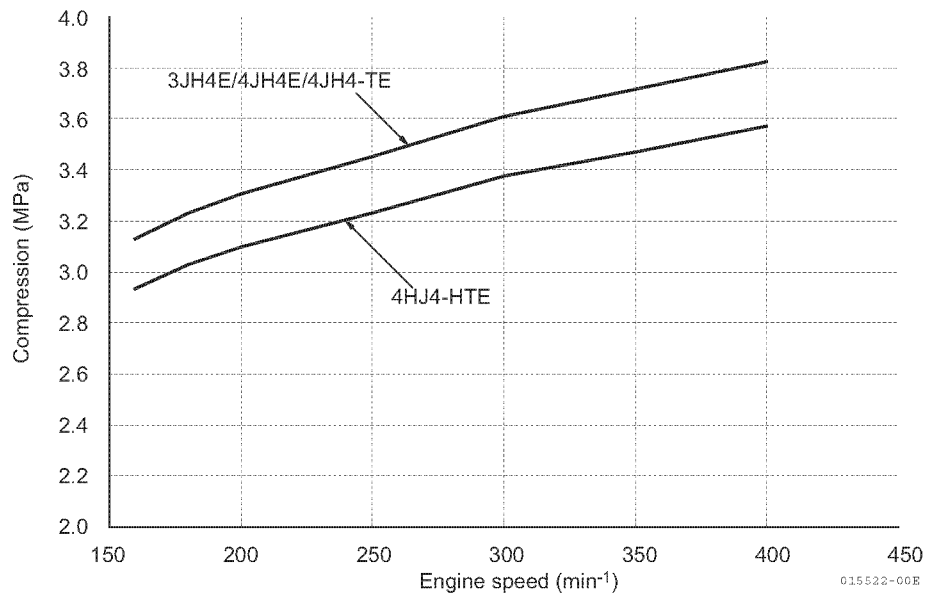

Figure 13-2

- Measured value and troubleshooting

When the measured compression pressure is below the limit value, inspect each part using the table below.

No.	Item	Cause	Corrective Action
1	<ul style="list-style-type: none"> Air cleaner element 	<ul style="list-style-type: none"> Clogged element Broken element Defect at element seal portion 	<ul style="list-style-type: none"> Clean the element. Replace the element. Replace seal.
2	<ul style="list-style-type: none"> Valve clearance 	<ul style="list-style-type: none"> Excessive or no clearance 	<ul style="list-style-type: none"> Adjust the valve clearance. (See <i>Adjust valve clearance - 2 valve cylinder head on page 5-94</i> and <i>Adjust valve clearance - 4 valve cylinder head on page 5-94</i>)
3	<ul style="list-style-type: none"> Valve timing 	<ul style="list-style-type: none"> Incorrect valve clearance 	<ul style="list-style-type: none"> Adjust the valve clearance. (See <i>Adjust valve clearance - 2 valve cylinder head on page 5-94</i> and <i>Adjust valve clearance - 4 valve cylinder head on page 5-94</i>)
4	<ul style="list-style-type: none"> Cylinder head gasket 	<ul style="list-style-type: none"> Gas leak from gasket 	<ul style="list-style-type: none"> Replace the gasket. Retighten the cylinder head bolts to the specified torque. (See <i>Install the cylinder head. NOTICE: Ensure the threaded bolt holes are clean and dry. If coolant or oil remains in the holes, there is a risk of cracking the cylinder block when the bolts are installed. on page 5-92</i>)
5	<ul style="list-style-type: none"> Intake/exhaust valve Valve seat 	<ul style="list-style-type: none"> Gas leak due to worn valve seat or foreign matter trapping Sticking valve 	<ul style="list-style-type: none"> Lap the valve seat. (See <i>Valve Seat Correction Procedure on page 5-54</i>) Replace the intake/exhaust valve.
6	<ul style="list-style-type: none"> Piston Piston ring Cylinder 	<ul style="list-style-type: none"> Gas leak due to scratching or wear 	<ul style="list-style-type: none"> Perform honing and/or use an oversized part.

AFTER TROUBLESHOOTING OR REPAIR

Check and clear any problems after repairs are complete.

Section 14

SERVICE STANDARDS

	Page
Engine Tuning	14-3
ENGINE TUNING	14-4
Engine Body	14-6
Cylinder Head.....	14-6
Camshaft and Gear Train	14-8
Cylinder Block.....	14-9
Lubricating Oil System (Trochoid Pump).....	14-14
Outside Clearance of Outer Rotor	14-14
Tip Clearance Between Outer Rotor and Inner Rotor	14-14
Side Clearance of Outer Rotor	14-14
Inside Clearance of Inner Rotor.....	14-14
Main Bolt and Nut.....	14-15
Standard Bolts and Nuts (Without Lubricating Oil)	14-16

This Page Intentionally Left Blank

ENGINE TUNING

No.	Inspection Item		Standard	Limit	Reference Page		
1	Intake / Exhaust Valve Clearance		0.15-0.25 mm (0.006-0.010 in.)	-	5-61		
2	V-belt Tension at 98 N, 10 kgf 22 lbf	Between Alternator and F.W. Pump	Used Part 8-10 mm 0.31-0.39 in.	-	11-9		
			New Part 6-8 mm (0.24-0.31 in.)	-			
3	Fuel Injection Pressure		3JH4E 4JH4-TE 4JH4-HTE	21.1-22.1 MPa, 215-225 kgf/cm ² (3060-3205 psi)	-	6-45	
			4JH4AE	19.6-20.6 MPa, 200-210 kgf/cm ² (2843-2988 psi)	-	6-45	
4	Compression Pressure at 250 minimum ¹ (rpm) MPa (kgf/cm ²)		3JH4E 4JH4AE 4JH4-TE	3.4±0.1 MPa, 35±1 kgf/cm ² (493±14 psi)	-	13-13	
			4JH4-HTE	3.2±0.1 MPa, 32±1 kgf/cm ² (464±14 psi)	-		
5	Coolant Capacity (L)		3JH4E	4.5 L (4.8 qt)	-	7-4	
			4JH4AE	6.0 L (6.3 qt)	-		
			4JH4-TE/ 4JH4-HTE	7.2 L (7.6 qt)	-		
			Coolant Recovery Tank	0.8 L (0.8 qt)	-		
6			Total	Effective	Reference		
	Lubricating Oil Capacity of 3JH4E		Engine (with KM35P, at rake angle 8°)		5.0±0.3 L (5.3±0.3 qt)	1.1 L (1.2 qt)	3-46
			Engine (with KM35A/SD40, at rake angle 0°)		5.5±0.3 L (5.8±0.3 qt)	1.2 L (1.3 qt)	3-46
			Marine Gear	KM35P	0.5 L (0.5 qt)	-	3-46
				KM35A	0.65 L (0.7 qt)	-	3-46
	Lubricating Oil Capacity of 4JH4AE		Engine (with KM35P/ ZF30M, at rake angle 8°)		5.0±0.3 L (5.3±0.3 qt)	1.2 L (1.3 qt)	3-47
			Engine (with KM35A2/ KM4A1/ SD50, at Rake Angle 0°)		5.0±0.3 L (5.3±0.3 qt)	1.4 L (1.5 qt)	3-47
			Marine Gear	KM35P	0.5 L (0.5 qt)	-	3-48
				KM35A2	0.65 L (0.7 qt)	-	3-48
				ZF30M	1.1 L (1.2 qt)	-	3-48
				KM4A	1.3 L (1.4 qt)	-	3-48

ENGINE TUNING

No.	Inspection Item		Standard	Limit	Reference Page	
6			Total	Effective		
	Lube Oil Capacity of 4JH4-TE/ 4JH4-HTE	Engine (with ZF30M, at rake angle 7°)	5.7±0.3 L (6±0.3 qt)	2.4 L (2.5 qt)	3-51	
		Engine (with KMH4A/ KM4A2/ ZF25A/ SD50, at rake angle 0°)	6.9±0.3 L (7.3±0.3 qt)	2.4 L (2.5 qt)	3-51	
		Marine Gear	ZF30M	1.1 L (1.2 qt)	0.2 L (0.2 qt)	3-52
			KMH4A	2.0 L (2.1 qt)	0.2 L (0.2 qt)	3-52
			KM4A2	2.0 L (2.1 qt)	0.2 L (0.2 qt)	3-52
			ZF25A	1.8 L (1.9 qt)	-	3-52
			SD50-4T (4JH4-TE only)	2.2 L (2.3 qt)	0.1 L (0.1 qt)	3-52
7	Lubricating Oil Pressure	3JH4E	0.39-0.54 MPa, 4.0-5.5 kgf/cm ² (57-78 psi)	0.06 MPa, 0.6 kgf/cm ² (8.7 psi) or above	8-4	
		4JH4AE	0.29-0.39 MPa, 3.0-4.0 kgf/cm ² (42-57 psi)	0.06 MPa, 0.6 kgf/cm ² (8.7 psi) or above	8-4	
		4JH4-TE/ 4JH4-HTE	0.28-0.45 MPa, 2.9-4.6 kgf/cm ² (41-65 psi)	0.06 MPa, 0.6 kgf/cm ² (8.7 psi) or above	8-4	
8	Oil Pressure Switch Operating Pressure		0.02±0.01 MPa 0.2±0.1 kgf/cm ² (2.9±1.5 psi)	-	8-6	

9	Thermostat		Valve opening temperature	Full opening lift	Reference Page
			75.0-78.0°C (167-172°F)	8 mm (0.31 in.) or above at 90°C (194°F)	5-11
10	Thermo Switch Actuating Temperature	ON	97-103°C (207-217°F)	-	5-11
		OFF	90°C (194°F) or more		5-11
11	Top Clearance		0.68-0.80 mm (0.0027-0.0031 in.)	-	5-60

ENGINE BODY

Cylinder Head

Cylinder Head

Inspection Item			Standard	Limit	Reference Page
Combustion surface distortion			0.05 mm (0.002 in.) or less	0.15 mm (0.006 in.)	5-5
Valve sink	3JH4E 4JH4-TE 4JH4-HTE	Intake Exhaust	0.30-0.50 mm (0.001-0.002 in.)	0.8 mm (0.003 in.)	5-5
	4JH4AE	Intake Exhaust	0.39-0.50 (0.0015-0.002 in.)	0.8 mm (0.003 in.)	5-5
Valve seat	Seat angle	Intake	120°	-	5-5
		Exhaust	90°	-	5-5

Intake/Exhaust Valve and Guide

	Inspection Item		Standard	Limit	Reference Page
3JH4E 4JH4AE	Intake	Guide Inside Diameter	8.010-8.025 mm (0.315-0.316 in.)	8.10 mm (0.32 in.)	5-56
		Valve Stem Outside Diameter	7.955-7.975 mm (0.313-0.314 in.)	7.90 mm (0.31 in.)	5-56
		Clearance	0.035-0.070 mm (0.0014-0.0028 in.)	0.18 mm (0.007 in.)	5-56
	Exhaust	Guide Inside Diameter	8.015-8.030 mm (0.3155-0.3161 in.)	8.10 mm (0.32 in.)	5-56
		Valve Stem Outside Diameter	7.955-7.970 mm (0.3132-0.3137 in.)	7.90 mm (0.31 in.)	5-56
		Clearance	0.045-0.075 mm (0.0018-0.003 in.)	0.18 mm (0.007 in.)	5-56
	Valve Guide Projection from Cylinder Head		14.7-15.0 mm (0.579-0.591 in.)	-	5-57
	Valve Guide Driving-in Method		Cold-fitted	-	5-56
	4JH4-TE 4JH4-HTE	Intake	Guide Inside Diameter	6.000-6.015 mm (0.2362-0.2368 in.)	6.1 mm (0.24 in.)
Valve Stem Outside Diameter			5.960-5.975 mm (0.2346-0.2352 in.)	5.90 mm (0.23 in.)	5-56
Clearance			0.025-0.055 mm (0.00098-0.0021 in.)	0.16 mm (0.006 in.)	5-56
Exhaust		Guide Inside Diameter	6.000-6.015 mm (0.2362-0.2368 in.)	6.1 mm (0.24 in.)	5-56
		Valve Stem Outside Diameter	5.945-5.960 mm (0.2341-0.2347 in.)	5.90 mm (0.23 in.)	5-56
		Clearance	0.040-0.070 mm (0.0016-0.0028 in.)	0.18 mm (0.007 in.)	5-56
Valve Guide Projection from Cylinder Head		8.2-8.5 mm (0.32-0.34 in.)	-	5-57	
Valve Guide Driving-in Method		Cold-fitted	-	5-57	

Valve Spring

Inspection Item		Standard	Limit	Reference Page
Free Length	3JH4E/ 4JH4AE	44.4 mm (1.75 in.)	43.0 mm (1.69 in.)	5-59
	4JH4-TE/ 4JH4-HTE	37.4 mm (1.47 in.)	36.9 mm (1.45 in.)	5-59
Inclination		-	1.1 ^o	5-59

Rocker Arm and Shaft

Inspection Item	Standard	Limit	Reference Page
Arm Shaft Hole Diameter	16.000-16.020 mm (0.6299-0.6307 in.)	16.090 mm (0.6335 in.)	5-6
Shaft Outside Diameter	15.966-15.984 mm (0.6286-0.6293 in.)	15.955 mm (0.6282 in.)	5-6
Clearance	0.016-0.054 mm (0.00059-0.0021 in.)	0.140 mm (0.0055 in.)	5-6

Push Rod

Inspection Item	Standard	Limit	Reference Page
Bend	Less than 0.03 mm (0.001 in.)	0.03 mm (0.001 in.)	5-80

Camshaft and Gear Train

Camshaft

Inspection Item		Standard	Limit	Reference Page
Side Gap		0.05-0.20 mm (0.002-0.008 in.)	0.35 mm (0.014 in.)	5-89
Bending (1/2 the Dial Gauge Reading)		0.02 mm or less (0.0008 in.)	0.05 mm (0.002 in.)	5-89
Cam Height	3JH4E/ 4JH4AE	38.600-38.800 mm (1.52-1.53 in.)	38.350 mm (1.51 in.)	5-6
	4JH4-TE/ 4JH4-HTE	39.800-40.000 mm (1.567-1.575 in.)	39.550 mm (1.557 in.)	5-6
Shaft Outside Diameter / Metal Inside Diameter				
Gear Side	Bushing Inside Diameter	44.990-45.055 mm (1.771-1.773 in.)	45.130 mm (1.777 in.)	5-77
	Camshaft Outside Diameter	44.925-44.950 mm (1.7687-1.7697 in.)	44.890 mm (1.767 in.)	5-77
	Clearance	0.040-0.130 mm (0.0016-0.0051 in.)	0.240 mm (0.0095 in.)	5-77
Intermediate	Bushing Inside Diameter	45.000-45.025 mm (1.771-1.773 in.)	45.100 mm (1.776 in.)	5-77
	Camshaft Outside Diameter	44.910-44.935 mm (1.7681-1.7691 in.)	44.875 mm (1.7667 in.)	5-77
	Clearance	0.065-0.115 mm (0.0026-0.0045 in.)	0.225 mm (0.0089 in.)	5-77
Flywheel End	Bushing Inside Diameter	45.000-45.025 mm (1.771-1.773 in.)	45.100 mm (1.776 in.)	5-77
	Camshaft Outside Diameter	44.925-44.950 mm (1.7687-1.7697 in.)	44.890 mm (1.767 in.)	5-77
	Clearance	0.050-0.100 mm (0.002-0.004 in.)	0.210 mm (0.008 in.)	5-77

Idle Gear Shaft and Bushing

Inspection Item	Standard	Limit	Reference Page
Shaft Outside Diameter	45.950-45.975 mm (1.8091-1.810 in.)	45.880 mm (1.8063 in.)	5-80
Bushing Inside Diameter	46.000-46.025 mm (1.811-1.812 in.)	46.075 mm (1.814 in.)	5-80
Clearance	0.025-0.075 mm (0.00098 in.)	0.150 mm (0.0059 in.)	5-80

Backlash of Each Gear

Inspection Item	Standard	Limit	Reference Page
Crank Gear, Cam Gear, Idle Gear, Fuel Injection Pump Gear and Seawater Pump Gear	0.07-0.15 mm (0.003-0.006 in.)	0.17 mm (0.007 in.)	5-80

Cylinder Block

Cylinder Block

Inspection Item	Standard	Limit	Reference Page	
Cylinder Inside Diameter	3JH4E/ 4JH4AE	88.000-88.030 mm (3.465-3.466 in.)	88.200 mm (3.472 in.)	5-7
	4JH4-TE/ 4JH4-HTE	84.000-84.030 mm (3.307-3.308 in.)	84.200 mm (3.315 in.)	5-7
Cylinder Bore	Roundness	0.01 mm or less (0.0004 in.)	0.03 mm (0.001 in.)	5-7
	Inclination			

Crankshaft

Inspection Item	Standard	Limit	Reference Page	
Bending (1/2 the Dial Gauge Reading)	-	0.02 mm (0.0008 in.)	5-72	
Crank Pin	Pin outside diameter	47.952-47.962 mm (1.8879-1.8883 in.)	47.902 mm (1.8859 in.)	5-73
	Metal inside diameter	48.000-48.026 mm (1.8898-1.8908 in.)	-	5-73
	Metal thickness	1.492-1.500 mm (0.0587-0.0591 in.)	-	5-73
	Clearance	0.038-0.083 mm (0.0015-0.003 in.)	0.150 mm (0.006 in.)	5-73
Crank Journal (Selective Pairing)	Journal outside diameter	49.952-49.962 mm (1.9666-1.9670 in.)	49.902 mm (1.9646 in.)	5-73
	Metal inside diameter	51.000-51.010 mm (2.0078-2.0083 in.)	-	5-73
	Metal thickness	1.995-2.010 mm (0.0785-0.0791 in.)	-	5-73
	Clearance	0.038-0.068 mm (0.015-0.027 in.)	0.150 mm (0.006 in.)	5-73

Thrust Bearing

Inspection Item	Standard	Limit	Reference Page
Crankshaft Side Gap	0.14-0.22 mm (0.0055-0.0087)	0.30 mm (0.012 in.)	5-74

Piston and Ring

Piston

Inspection Item	Standard	Limit	Reference Page	
Piston Outside Diameter (Measure in the Direction Vertical to the Piston Pin.)	3JH4E	87.950-87.960 mm (3.4626-3.4630 in.)	87.900 mm (3.4606 in.)	5-63
	4JH4AE	87.935-87.945 mm (3.4619-3.4624 in.)	87.885 mm (3.4600 in.)	5-63
	4JH4-TE/ 4JH4-HTE	83.930-83.940 mm (3.4224-3.4228 in.)	83.880 mm (3.3024 in.)	5-63
Clearance Between Piston and Cylinder	3JH4E	0.045-0.075 mm (0.002-0.003 in.)	-	5-63
	4JH4AE	0.06-0.090 mm (0.0024-0.0035 in.)	-	5-63
	4JH4-TE/ 4JH4-HTE	0.065-0.095 mm (0.0026-0.0037 in.)	-	5-63
Piston Diameter Measure Position (Upward from the Bottom End of the Piston)		22 mm (0.87 in.)	-	5-8
3JH4E 4JH4AE	Piston Pin Hole Inside Diameter	26.000-26.009 mm (1.0236-1.0272 in.)	26.020 mm (1.0244 in.)	5-64
	Piston Pin Outside Diameter	25.995-26.000 mm (1.0234-1.0236 in.)	25.965 mm (1.0222 in.)	5-64
	Clearance Between Piston Pin and Hole	0.000-0.014 mm (0.0-0.00055 in.)	0.074 mm (0.0029 in.)	5-64
4JH4-TE 4JH4-HTE	Piston Pin Hole Inside Diameter	28.000-28.009 mm (1.1023-1.1027 in.)	28.020 mm (1.1031 in.)	5-64
	Piston Pin Outside Diameter	27.995-28.000 mm (1.1022-1.1024 in.)	27.965 mm (1.1010 in.)	5-64
	Clearance Between Piston Pin and Hole	0-0.014 mm (0.0-0.00055 in.)	0.074 mm (0.0029 in.)	5-64

Piston ring

Inspection Item		Standard	Limit	Reference Page	
3JH4E 4JH4AE	Top Ring	Ring Groove Width	2.060-2.075 mm (0.0811-0.0817 in.)	2.170 mm (0.0854 in.)	5-66
		Ring Width	1.970-1.990 mm (0.0776-0.0783 in.)	1.950 mm (0.0768 in.)	5-66
		Side Clearance	0.070-0.105 mm (0.0028-0.0041 in.)	0.200 mm (0.0079 in.)	5-66
		End Clearance (Gap)	0.200-0.400 mm (0.0079-0.0157 in.)	0.490 mm (0.0193 in.)	5-66
	Second Ring	Ring Groove Width	2.025-2.040 mm (0.0797-0.0803 in.)	2.140 mm (0.0843 in.)	5-66
		Ring Width	1.970-1.990 mm (0.0776-0.0783 in.)	1.950 mm (0.0768 in.)	5-66
		Side Clearance	0.035-0.070 mm (0.00138-0.00276 in.)	0.190 mm (0.0075 in.)	5-66
		End Clearance (Gap)	0.200-0.400 mm (0.0079-0.0157 in.)	0.490 mm (0.0193 in.)	5-66
	Oil Ring	Ring Groove Width	4.015-4.030 mm (0.1581-0.1587 in.)	4.130 mm (0.1626 in.)	5-66
		Ring Width	3.970-3.990 mm (0.1563-0.1571 in.)	3.950 mm (0.1555 in.)	5-66
		Side Clearance	0.025-0.060 mm (0.00098-0.0024 in.)	0.180 mm (0.0071 in.)	5-66
		End Clearance (Gap)	0.200-0.400 mm (0.0079-0.0157 in.)	0.490 mm (0.0193 in.)	5-66

Piston Ring (continued)

4JH4-TE 4JH4-HTE	Top Ring	Ring Groove Width	2.060-2.080 mm (0.0811-0.0818 in.)	2.180 mm (0.0858 in.)	5-66
		Ring Width	1.970-1.990 mm (0.0776-0.0783 in.)	1.950 mm (0.0768 in.)	5-66
		Side Gap	(half-keystone)	-	5-66
		End Clearance (Gap)	0.200-0.400 mm (0.0079-0.0157 in.)	0.490 mm (0.0193 in.)	5-66
	Second Ring	Ring Groove Width	2.050-2.065 mm (0.0807-0.0813 in.)	2.170 mm (0.0854 in.)	5-66
		Ring Width	1.970-1.990 mm (0.0776-0.0783 in.)	1.950 mm (0.0768 in.)	5-66
		Side Clearance	0.060-0.095 mm (0.0024-0.0037 in.)	0.220 mm (0.0087 in.)	5-66
		End Clearance (Gap)	0.200-0.400 mm (0.0079-0.0157 in.)	0.490 mm (0.0193 in.)	5-66
	Oil Ring	Ring Groove Width	4.020-4.035 mm (0.1583-0.1589 in.)	4.135 mm (0.1628 in.)	5-66
		Ring Width	3.970-3.990 mm (0.1563-0.1571 in.)	3.950 mm (0.1555 in.)	5-66
		Side Clearance	0.030-0.065 mm (0.0012-0.0026 in.)	0.180 mm (0.007 in.)	5-66
		End Clearance (Gap)	0.200-0.400 mm (0.0079-0.0157 in.)	0.490 mm (0.0193 in.)	5-66

Connecting Rod

Rod Big End

Inspection Item	Standard	Limit	Reference Page
Side Clearance	0.20-0.40 mm (0.0079-0.0157 in.)	0.55 mm (0.0217 in.)	5-7

Rod Small End

Item		Standard	Limit	Reference Page
Piston Pin Bushing Inside Diameter	3JH4E	26.025-26.038 mm (1.0246-1.0251 in.)	26.068 mm (1.0263 in.)	5-71
	4JH4AE	26.000-26.009 mm (1.0236-1.0240 in.)	26.039 mm (1.0251)	5-71
3JH4E 4JH4AE	Piston Pin Outside Diameter	25.995-26.000 mm (1.0234-1.0236 in.)	25.965 mm (1.0222 in.)	5-64
	Clearance	0.025-0.043 mm (0.00098-0.00169 in.)	0.101 mm (0.00397 in.)	5-71
4JH4-TE 4JH4-HTE	Piston Pin Bushing Inside Diameter	28.025-28.038 mm (1.1033-1.1039 in.)	28.068 mm (1.0263 in.)	5-71
	Piston Pin Outside Diameter	27.995-28.000 mm (1.1021-1.1023 in.)	27.965 mm (1.1010 in.)	5-64
	Clearance	0.025-0.043 mm (0.00098-0.00169 in.)	0.101 mm (0.00397 in.)	5-71

Tappet

Inspection item		Standard	Limit	Reference Page
3JH4E 4JH4AE	Tappet Guide Hole Inside Diameter	12.000-12.018 mm (0.4724-0.4732 in.)	12.045 mm (0.4742 in.)	5-79
	Tappet Stem Outside Diameter	11.975-11.990 mm (0.4715-0.4721 in.)	11.930 mm (0.4697 in.)	5-79
	Clearance	0.010-0.043 mm (0.00039-0.00169 in.)	0.090 mm (0.0035 in.)	5-79
4JH4-TE 4JH4-HTE	Tappet Guide Hole Inside Diameter	12.000-12.025 mm (0.4724-0.4734 in.)	12.052 mm (0.4745 in.)	5-79
	Tappet Stem Outside Diameter	11.975-11.990 mm (0.4715-0.4721 in.)	11.930 mm (0.4697 in.)	5-79
	Clearance	0.010-0.050 mm (0.00039-0.00197 in.)	0.097 mm (0.0038)	5-79

LUBRICATING OIL SYSTEM (TROCHOID PUMP)

Outside Clearance of Outer Rotor

Standard	Limit	Reference Page
0.12-0.21 mm (0.0047-0.0083 in.)	0.30 mm (0.012 in.)	8-13

Tip Clearance Between Outer Rotor and Inner Rotor

Standard	Limit	Reference Page
-	0.16 mm (0.0063 in.)	8-13

Side Clearance of Outer Rotor

Standard	Limit	Reference Page
0.02-0.07 mm (0.0008-0.0028 in.)	0.12 mm (0.0047 in.)	8-13

Inside Clearance of Inner Rotor

Item	Parts	Standard	Standard	Limit	Reference Page
Inside Clearance of Inner Rotor	Gear Boss Diameter	53.05-53.15 mm (2.089-2.092 in.)	0.3-0.5 mm (0.012-0.020 in.)	0.6 mm (0.024 in.)	8-14
	Rotor Diameter	53.45-53.55 mm (2.104-2.108 in.)			
Width Across Flat Clearance of Inner Rotor	Width Across Flat of Gear Boss	49.45-49.75 mm (1.9468-1.9587 in.)	0.2-0.6 mm (0.0079-0.0236 in.)	0.7 mm (0.028 in.)	8-14
	Width Across Flat of Rotor	49.95-50.05 mm (1.9665-1.9705 in.)			

MAIN BOLT AND NUT

No.	Name	Thread Diameter x Pitch (mm)		Lubricating Oil Application (Thread Portion, and Seat Surface)	Torque
1	Head Bolt	M10 x 1.25		Coat with lubricating oil	85.2-91.2 N·m, 8.69-9.30 kgf/m (62.8-67.3 lb-ft)
2	Rod Bolt	M9 x 1.0		Coat with lubricating oil	44.1-49.1 N·m, 4.50-5.01 kgf/m (32.5-36.2 lb-ft)
3	Flywheel Bolt	M10 x 1.25		Coat with lubricating oil	83.3-88.3 N·m, 8.49-9.00 kgf/m (61.4-65.1 lb-ft)
4	Metal cap Bolt	M12 x 1.5		Coat with lubricating oil	96-100 N·m, 9.79-10.2 kgf/m (70.8-73.8 lb-ft)
5	Crankshaft Pulley Bolt (FC300 Pulley)	M14 x 1.5		Coat with lubricating oil	83.2-93.2 N·m, 8.48-9.50 kgf/m (61.4-68.7 lb-ft)
6	Nozzle Retainer Bolt	M8 x 1.25		No lubricating oil	24.4-28.4 N·m, 2.49-2.90 kgf/m (18.0-21.0 lb-ft)
7	Fuel Injection Pump Gear Nut	3JH4E	M14 x 1.5	No lubricating oil	78-88 N·m, 8-9 kgf/m (57.5-64.9 lb-ft)
		4JH4AE	M8 x 1.0	No lubricating oil	32.3-36.3 N·m, 3.3-3.7 kgf/m (23.8-26.8 lb-ft)
		4JH4-TE 4JH4-HTE	M14 x 1.5	Coat with lubricating oil	59-69 N·m, 6-7 kgf/m (43.5-50.9 lb-ft)
8	Fuel Injection Line Joint Nut	M12 x 1.5		No lubricating oil	29.4-34.4 N·m, 3.00-3.51 kgf/m (21.7-25.4 lb-ft)
9	Heat Exchanger Set Bolt	M8 x 1.25		No lubricating oil	34.2-40.2 N·m, 3.49-4.10 kgf/m (25.2-29.7 lb-ft)
10	Starter Relay Terminal Nut (Magnetic Relay)	M6 x 1.0		No lubricating oil	3.0-4.2 N·m, 0.31-0.43 kgf/m (2.2-3.1 lb-ft)

STANDARD BOLTS AND NUTS (WITHOUT LUBRICATING OIL)

Name	bolt dia. x pitch (mm)	Tightening torque	Remarks
Hexagon Bolt with a "7" Head and Hexagon Nut. ("7" Mark Means JIS Strength Classification "7T".)	M6 x 1	9.8-11.8 N·m, 1.0-1.2 kgf/m (7.2-8.7 lb-ft)	Apply 80% torque when tightening to aluminum alloy. Apply 60% torque to 4T bolts and locknuts. (4T bolt has no mark on the head.)
	M8 x 1.25	22.5-28.5 N·m, 2.3-2.9 kgf/m (16.6-21.0 lb-ft)	
	M10 x 1.5	44-54 N·m, 4.5-5.5 kgf/m (32.5-39.8 lb-ft)	
	M12 x 1.75	78.2-98.2 N·m, 8.0-10.0 kgf/m (57.7-72.4 lb-ft)	
Pt Plug (Taper Plug)	1/8	9.8 N·m, 1.0 kgf/m (7.2 lb-ft)	-
	1/4	19.6 N·m, 2.0 kgf/m (14.4 lb-ft)	
	3/8	29.4 N·m, 3.0 kgf/m (21.7 lb-ft)	
	1/2	58.8 N·m, 6.0 kgf/m (43.4 lb-ft)	
Line Joint Bolt	M8	12.7-16.7 N·m, 1.3-1.7 kgf/m (9.4-12.3 lb-ft)	-
	M10	19.5-25.5 N·m, 2.0-2.6 kgf/m (14.4-18.8 lb-ft)	
	M12	24.4-34.4 N·m, 2.5-3.5 kgf/m (18.0-25.4 lb-ft)	
	M14	39.1-49.1 N·m, 4.0-5.0 kgf/m (28.8-36.2 lb-ft)	
	M16	48.9-58.9 N·m, 5.0-6.0 kgf/m (36.1-43.4 lb-ft)	